

RCD-RA1DA

ROBO Cylinder, Ultra-Compact Rod Type, Actuator Width 12mm, DC24V Brushless Motor

Model Specification Items

RCD - RA1DA - I - 3 - 2 - [] - D5 - []

Series — Type — Encoder Type — Motor Type — Lead — Stroke — Applicable Controllers — Cable Length

I: Incremental 3: DC Brushless Motor 2.5W 2: 2mm 10: 10mm
 ~ 30: 30mm (Every 10mm) D5: DSEP, DCON, MSEP N: None, P: 1m, S: 3m, M: 5m
 X[]: Custom length R[]: Robot cable

Controller is not included.

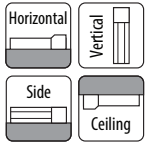

*If you install in a vertical position, there are restrictions applied depending on the model.



- (1) The load capacity is based on operation at an acceleration of 1G. This is the upper limit of the acceleration/deceleration speed.
- (2) The horizontal payload is the value when used in combination with an external guide. Please note that if an external force is applied to the rod in a direction other than the proper direction the rod travels, the detent may get damaged.
- (3) The push motion is when operated at 5mm/s.
- (4) Since this model uses a lead screw, the actuator specifications may change according to the usage.
- (5) Take note that, since there is no brake, the rod may come down when the power is turned off if the actuator is used vertically.

Electric Current Limit and Pushing Force

Electric current limit and pushing force

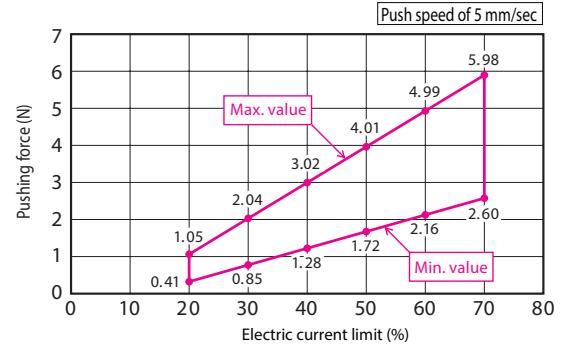

* The ranges shown in this graph take into account efficiency deterioration caused by wear on the lead screw. Always use the product within the maximum and minimum values.

Actuator Specifications

Lead and Payloads

Model Number	Motor Output (W)	Feed Screw	Lead (mm)	Maximum Payload		Maximum Push Force (N)	Stroke (mm)
				Horizontal (kg)	Vertical (kg)		
RCD-RA1DA-I-3-2-①-D5-②	2.5	Lead Screw	2	0.7	0.3	4.2	10 to 30 (Every 10 mm)

Legend: ① Stroke ② Cable length

Stroke and Maximum Speed

Lead (mm)	10~30 (Every 10mm)
2	300

(Unit: mm/s)

① Stroke

Stroke (mm)	Standard Price
10	—
20	—
30	—

② Cable Length

Type	Cable Code	Standard Price
Standard Type	P (1m)	—
	S (3m)	—
	M (5m)	—
Special Length	X06 (6m) ~ X10 (10m)	—
	X11 (11m) ~ X15 (15m)	—
	X16 (16m) ~ X20 (20m)	—
	R01 (1m) ~ R03 (3m)	—
Robot Cable	R04 (4m) ~ R05 (5m)	—
	R06 (6m) ~ R10 (10m)	—
	R11 (11m) ~ R15 (15m)	—
	R16 (16m) ~ R20 (20m)	—

Actuator Specifications

Item	Description
Drive Method	Ball screw, ø3mm
Positioning Repeatability	±0.05mm
Lost Motion	0.2mm or less
Encoder Resolution	480 pulses/rev
Base	Material: Aluminum, white alumite treated
Rod Allowable Static Moment	0.02 N·m
Rod Non-rotation Precision	±3 deg
Ambient Operating Temperature/Humidity	0 to 40°C, 85% RH max. (Non-condensing)
Service Life	10 million cycles (for horizontal and vertical)

Dimensional Drawings

CAD drawings can be downloaded from the website.

www.intelligentactuator.com

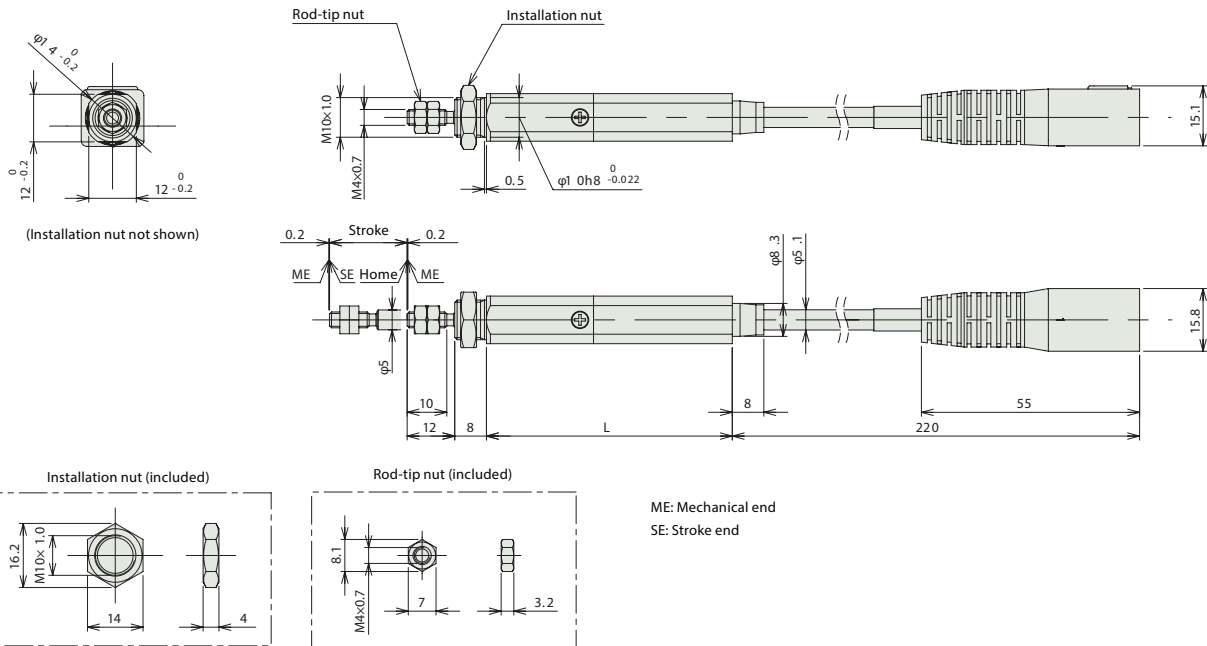

Stroke	10	20	30
L	52	62	72
Weight (g)	47	51	55

Applicable Controllers

RCD series actuators can be operated with the controllers indicated below. Select the type according to your intended application.

Name	External View	Model	Max. Number of Connectable Axes	Max. Positioning Points	Input Voltage	Standard Price
Solenoid Valve Type		DSEP-C-3I-①-2-0	1	3 points	DC24V	—
Dust-proof Solenoid Valve Type		DSEP-CW-3I-①-2-0				—
Solenoid Valve Multi-axis Type (PIO Specification)		MSEP-③-④-~①-2-0	C : 8 LC : 6	3 points		—
Solenoid Valve Multi-axis Type (Network Specification)		MSEP-③-④-~②-0-0		256 points		—
Positioner Type		DCON-CA-3I-①-2-0	1	512 points		—
Network Type		DCON-CA-3I-②-0-0		768 points		—

*① indicates I/O type (NP/PN) *② indicates Field Network specification code *③ indicates C (standard) or LC (with PLC function) type *④ indicates the number of axes

IAI America, Inc.

Headquarters: 2690 W. 237th Street, Torrance, CA 90505 (800) 736-1712
 Chicago Office: 110 E. State Pkwy, Schaumburg, IL 60173 (800) 944-0333
 Atlanta Office: 1220 Kennestone Circle, Suite 108, Marietta, GA 30066 (888) 354-9470

www.intelligentactuator.com

The information contained in this product brochure may change without prior notice due to product improvements.

IAI Industrieroboter GmbH

Ober der Röth 4, D-65824 Schwalbach am Taunus, Germany

IAI Robot (Thailand), CO., Ltd.

825 PhairojKijja Tower 12th Floor, Bangna-Trad RD.,
 Bangna, Bangna, Bangkok 10260, Thailand

