

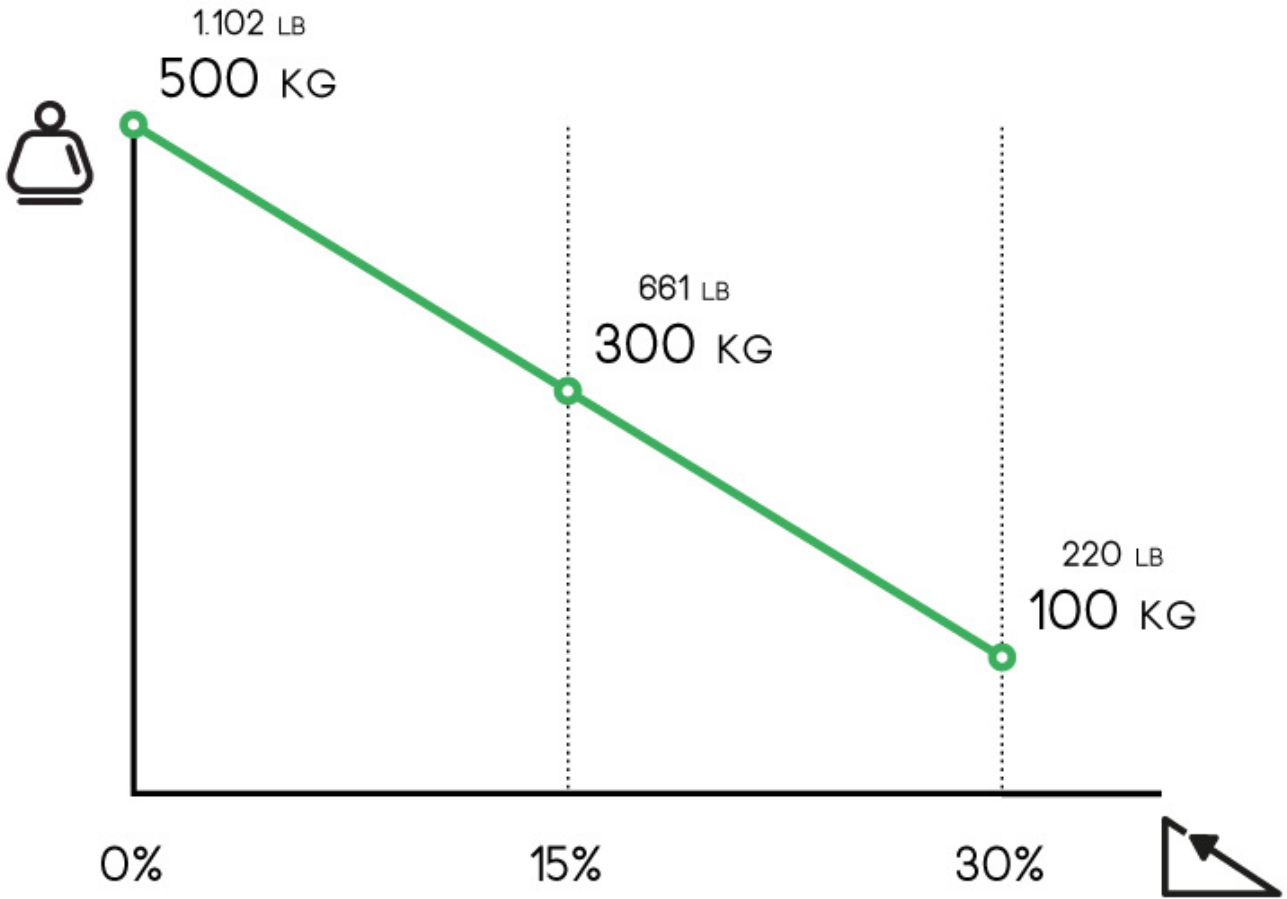

...the passion for moving

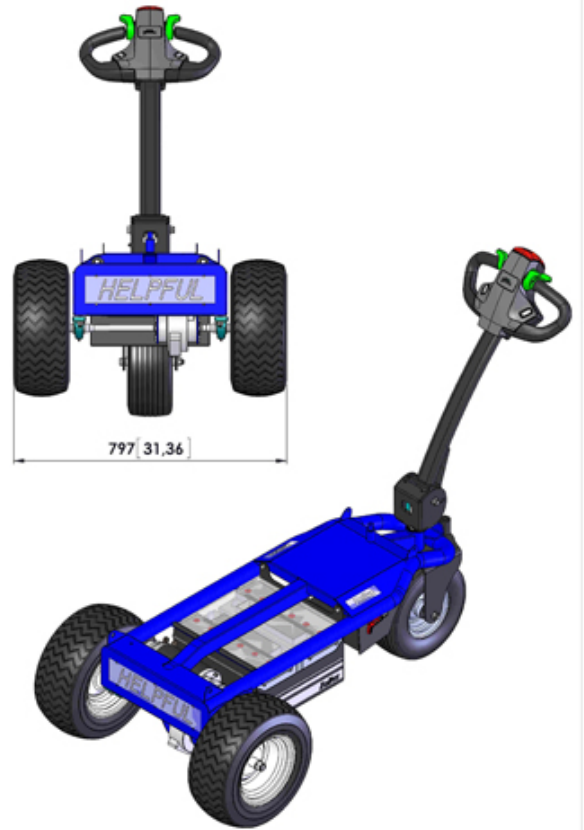

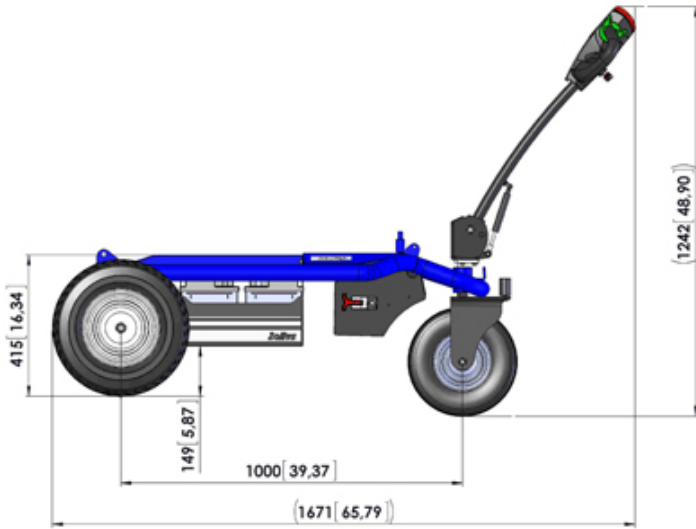

Zallys

TABLE:

Z104.720

HT

Unit: mm / [inch]

1:10

Characteristics		Tolerance	M.U.	.
1.01	Model number			Z104.720-8
1.02	Model name			HT
1.03	Manufacturer			ZALLY
1.04	Operator			Pedestrian
1.05	Power unit			Electric
1.06	UL certification			
1.07	CE certification			

Frame characteristics		Tolerance	M.U.	.
1.80	Frame made of			Steel
1.82	Anti-Corrosion Treatment (on customer demand only)			Cataphoresis
1.83	Frame treatment			Polyester powder coating

Safety data		Tolerance	M.U.	.
2.01	Dead man safety system			Sensor on tiller head
2.02	Emergency reverse button			On tiller head
2.04	Creep speed device			Button on tillerhead
2.06	Power supply disconnection device / Emergency stop			Detachable power connector
2.11	Drive controls			Maintained action switch

Performances		Tolerance	M.U.	.
3.01	Max. forward speed	± 5 %	km/h	5
3.02	Max. backward speed	± 5 %	km/h	5
3.06	Max.load capacity on flat ground		kg	500
3.15	Max.slope with load *		%	30
3.38	* Load capacity is subject to kind of slope , kind of floor and operating time			

Drive controls		Tolerance	M.U.	.
4.01	Type of control			Tillerhead
4.02	Type of start control			Butterfly lever

Standard batteries		Tolerance	M.U.	.
5.01	Batteries			2
5.02	Batteries type			Traction lead acid batteries
5.03	Battery voltage		V	12
5.04	Nominal Capacity 5 h		Ah	72
5.05	Nominal Capacity 20 h		Ah	96
5.06	Weight of each battery		kg	25

Optional battery specifications		Tolerance	M.U.	.
5.11	Batteries pcs			2
5.12	Batteries type			Traction AGM batteries
5.13	Battery voltage		V	12
5.14	Nominal Capacity k5		Ah	50

5.15	Nominal Capacity k20		Ah	70
5.16	Weight of each battery		kg	22

Available chargers		Tolerance	M.U.	.
6.40	Standard voltage		V	220/240
6.41	Multitension		V	110/240
6.42	Plug			In use in the country of destination

Technical data of standard charger		Tolerance	M.U.	.
6.01	Battery charger			External - high frequency
6.02	Input voltage		V	230
6.03	Input Frequency		Hz	50-60

Optional charger specifications		Tolerance	M.U.	.
6.14	Charger suitable for AGM batteries of		A	50/70
6.19	**for all other details please refer to standard charger specifications			

Drive motor		Tolerance	M.U.	.
7.03	Engine			Electric
7.04	Electricity			Direct current
7.05	Engine voltage		V	24

Technical data		Tolerance	M.U.	.
8.01	Transmission system			Mechanical
8.02	Transmission lubrication			In oil bath
8.06	Service brake			Electronic
8.08	Parking brake			Electro-Mechanical

Weight		Tolerance	M.U.	.
9.01	Weight without batteries		kg	74
9.08	Weight incl. 72/96A lead acid batteries		kg	124
9.09	Weight incl. 50/70A AGM batteries		kg	118

Dimensions		Tolerance	M.U.	.
10.01	Length		mm	1671
10.02	Width		mm	797
10.03	Height of start control		mm	1242
10.08	Loading platform height		mm	415
10.14	Wheelbase		mm	1000
10.15	Turning circle		mm	2450
10.16	* with tiller in vertical position			
10.50	**For further details please click on technical draws			

Standard wheels		Tolerance	M.U.	.
11.01	Drive wheels			2

11.02	Steering wheels			1
11.05	Tyres			Pneumatic
11.07	Drive wheels type			Turf tires
11.09	Steering wheel type			Grooved tire
11.13	Drive tyres size			16-6.50-8"
11.15	Steering wheel size			13-5.00-6"
11.25	Inflation pressure		bar	2

Optional wheels		Tolerance	M.U.	.
11.42	Tyres			Super-elastic non-marking wheel
11.43	Kind of tyres			Turf tyres
11.44	Drive tyres size			4.00-8"
11.46	Steering wheel size			4.00-4"

Narrow track wheels		Tolerance	M.U.	.
11.61	Tyres			Pneumatic
11.63	Drive wheels tires draw			Turf tyres
11.68	Drive tyres size			4.00-8"