



LD *Linear Slot Diffuser*





Introduction



With its adjustable deflector blades for horizontal/vertical flow, the Linear Slot Diffuser (LDA) is designed to provide the highest flexibility in throw adjustment under most efficient operating requirement conditions (low noise and pressure loss). Both versatile and aesthetic, the Linear Slot Diffuser is suitable for supply and extracts applications.

Available in highly customizable shape designs, the Linear Slot Diffuser is commonly used in public areas such as offices and conference rooms, shopping malls etc. where pleasing and unconstructive diffuser element is required.

CONSTRUCTIONS & MATERIALS

- Available in 1-8 slot configurations
- Standard length of 1200 mm (available in multiple modules)
- Highly customizable shape profile
- Standard slot width 21 mm (customizable upon request)
- Wood construction available

Frame Construction

AL
1.2mm

Extruded Aluminium

Deflector Construction

AL
1.0mm

Extruded Aluminium

Surface Finishing

RAL
9010 SG

White (Matt)

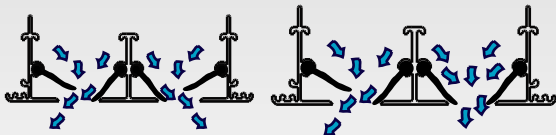

Opposed Sides

Vertical & Side Throw

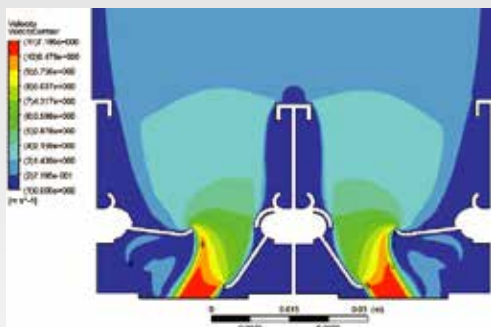

DIMENSIONS

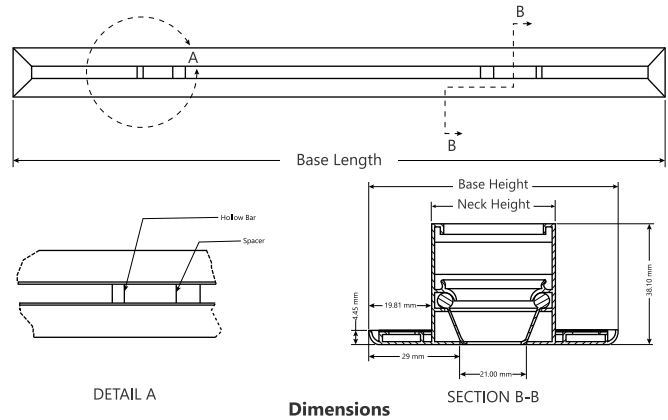

Number of Slots	Base Height (mm)	Neck Height (mm)
1	79	40
2	118	79
3	157	118
4	196	157
5	235	196
6	279	235
7	313	274
8	352	313

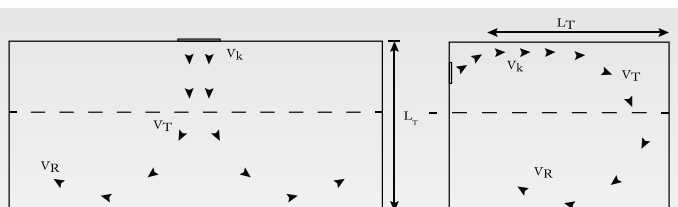

TECHNICAL PERFORMANCE DATA

Supply

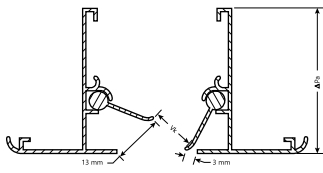

* For optimized horizontal throw distance (with Coanda effect), users are recommended to set the blade distance as shown in the illustration.

* The effective area given is to the best estimation & knowledge of Prudentaire's engineers at the point of entry.

Order Size, inch	Neck Area (Eff. Area) m ²	Unit Volume Flowrate, m ³ /hr/m Unit Volume Flowrate, l/s/m	NR20		NR30		NR40		NR50		
			107 30	143 40	214 60	357 100	536 150	714 200	893 250	1071 300	1250 350
1 Slot x 300 mm	0.012 (0.00219)	Total Volume Flowrate, m ³ /hr	32.1	42.9	64.2	107	-	-	-	-	-
		Throw Distance (0.25 m/s), m	0.7	1.2	2.4	4	-	-	-	-	-
		Face Velocity, m/s	4.1	5.4	8.1	13.6	-	-	-	-	-
		Total Pressure Loss, Pa	13	22	46	116	-	-	-	-	-
		Noise Rating (NR)	7	14	23	37	-	-	-	-	-
		Temperature Quotient	0.18	0.16	0.13	0.1	-	-	-	-	-
		Induction Ratio	5.5	6.5	8.2	10	-	-	-	-	-
1 Slot x 1200 mm	0.048 (0.00876)	Total Volume Flowrate, m ³ /hr	128	172	257	428	-	-	-	-	-
		Throw Distance (0.25 m/s), m	1.4	2.4	4.8	7.2	-	-	-	-	-
		Face Velocity, m/s	4.1	5.4	8.1	13.6	-	-	-	-	-
		Total Pressure Loss, Pa	13	22	46	116	-	-	-	-	-
		Noise Rating (NR)	10	17	26	40	-	-	-	-	-
		Temperature Quotient	0.14	0.125	0.09	<0.09	-	-	-	-	-
		Induction Ratio	7	8	11	>11	-	-	-	-	-
1 Slot x 2400 mm	0.096 (0.01752)	Total Volume Flowrate, m ³ /hr	257	344	514	856	-	-	-	-	-
		Throw Distance (0.25 m/s), m	1.6	2.8	5.52	8.3	-	-	-	-	-
		Face Velocity, m/s	4.1	5.4	8.1	13.6	-	-	-	-	-
		Total Pressure Loss, Pa	13	22	46	116	-	-	-	-	-
		Noise Rating (NR)	16	20	29	43	-	-	-	-	-
		Temperature Quotient	0.14	0.13	<0.09	<0.09	-	-	-	-	-
		Induction Ratio	7	9	>11	>11	-	-	-	-	-
2 Slot x 300 mm	0.0237 (0.00438)	Total Volume Flowrate, m ³ /hr	32.1	42.9	64.2	107	161	214	-	-	-
		Throw Distance (0.25 m/s), m	<0.2	0.2	0.7	2.4	3.3	5	-	-	-
		Face Velocity, m/s	2.0	2.7	4.1	6.8	10.2	13.6	-	-	-
		Total Pressure Loss, Pa	<6	6	13	33	75	116	-	-	-
		Noise Rating (NR)	<6	6	15	26	36	44	-	-	-
		Temperature Quotient	-	-	0.18	0.13	0.13	0.12	-	-	-
		Induction Ratio	-	-	5.5	8.2	8.2	8.5	-	-	-
2 Slot x 1200 mm	0.0948 (0.01752)	Total Volume Flowrate, m ³ /hr	128	172	257	428	643	857	-	-	-
		Throw Distance (0.25 m/s), m	<0.2	0.4	1.4	4.9	>7	>7	-	-	-
		Face Velocity, m/s	2.0	2.7	4.1	6.8	10.2	13.6	-	-	-
		Total Pressure Loss, Pa	<6	6	13	33	75	116	-	-	-
		Noise Rating (NR)	<10	9	18	29	39	47	-	-	-
		Temperature Quotient	-	-	0.19	0.12	<0.12	<0.12	-	-	-
		Induction Ratio	-	-	5.2	8.5	>8.5	>8.5	-	-	-
2 Slot x 2400 mm	0.1896 (0.03504)	Total Volume Flowrate, m ³ /hr	257	344	514	856	1286	1714	-	-	-
		Throw Distance (0.25 m/s), m	<0.2	0.46	1.61	5.6	>7	>7	-	-	-
		Face Velocity, m/s	2.0	2.7	4.1	6.8	10.2	13.6	-	-	-
		Total Pressure Loss, Pa	<6	6	13	33	75	116	-	-	-
		Noise Rating (NR)	<10	12	21	32	42	50	-	-	-
		Temperature Quotient	-	-	0.18	<0.12	<0.12	<0.12	-	-	-
		Induction Ratio	-	-	5.7	>8.5	>8.5	>8.5	-	-	-
3 Slot x 300 mm	0.0354 (0.00657)	Total Volume Flowrate, m ³ /hr	32.1	42.9	64.2	107	161	214	268	-	-
		Throw Distance (0.25 m/s), m	<0.2	<0.2	0.2	1.4	3.0	>5.0	>5.0	-	-
		Face Velocity, m/s	1.4	1.8	2.7	4.5	6.8	9.0	11.3	-	-
		Total Pressure Loss, Pa	<6	<6	6	15	33	57	85	-	-
		Noise Rating (NR)	<10	<10	11	22	30	35	42	-	-
		Temperature Quotient	-	-	-	0.23	0.18	<0.14	<0.14	-	-
		Induction Ratio	-	-	-	4.3	5.5	>7	>7	-	-
3 Slot x 1200 mm	0.1416 (0.02628)	Total Volume Flowrate, m ³ /hr	128	172	257	428	643	857	1072	-	-
		Throw Distance (0.25 m/s), m	<0.4	<0.4	0.4	3.0	6.0	>7.0	>7.0	-	-
		Face Velocity, m/s	1.4	1.8	2.7	4.5	6.8	9.1	11.3	-	-
		Total Pressure Loss, Pa	<6	<6	6	15	33	57	85	-	-
		Noise Rating (NR)	<10	<10	14	25	33	38	45	-	-
		Temperature Quotient	-	-	-	0.18	<0.14	<0.14	<0.14	-	-
		Induction Ratio	-	-	-	5.5	>7	>7	>7	-	-
3 Slot x 2400 mm	0.2832 (0.05256)	Total Volume Flowrate, m ³ /hr	257	344	514	856	1286	1714	2143	-	-
		Throw Distance (0.25 m/s), m	<0.5	<0.5	0.5	3.45	7	>7.0	>7.0	-	-
		Face Velocity, m/s	1.4	1.8	2.7	4.5	6.8	9.1	11.3	-	-
		Total Pressure Loss, Pa	<6	<6	6	15	33	57	85	-	-
		Noise Rating (NR)	<10	<10	17	28	35	41	48	-	-
		Temperature Quotient	-	-	-	0.17	<0.14	<0.14	<0.14	-	-
		Induction Ratio	-	-	-	5.8	>7	>7	>7	-	-
4 Slot x 300 mm	0.0471 (0.00876)	Total Volume Flowrate, m ³ /hr	32.1	42.9	64.2	107	161	214	268	321	375
		Throw Distance (0.25 m/s), m	<0.15	<0.15	0.15	1.0	2.5	3.5	>5.0	>5.0	>5.0
		Face Velocity, m/s	1.0	1.4	2.0	3.4	5.1	6.8	8.5	10.2	11.9
		Total Pressure Loss, Pa	<4	<4	4	9	20	33	40	75	90
		Noise Rating (NR)	<8	<8	8	19	27	34	39	42	45
		Temperature Quotient	-	-	-	0.33	0.22	0.2	<0.14	<0.14	<0.14
		Induction Ratio	-	-	-	3.1	4.3	5	>7	>7	>7
4 Slot x 1200 mm	0.1884 (0.03504)	Total Volume Flowrate, m ³ /hr	128	172	257	428	643	857	1072	1285	1500
		Throw Distance (0.25 m/s), m	<0.3	<0.3	0.3	1.9	5.2	>7.0	>7.0	>7.0	>7.0
		Face Velocity, m/s	1.0	1.4	2.0	3.4	5.1	6.8	8.5	10.2	11.9
		Total Pressure Loss, Pa	<4	<4	4	9	20	33	40	75	90
		Noise Rating (NR)	<10	<10	11	22	30	37	42	45	48
		Temperature Quotient	-	-	-	0.24	<0.14	<0.14	<0.14	<0.14	<0.14
		Induction Ratio	-	-	-	4	>7	>7	>7	>7	>7
4 Slot x 2400 mm	0.3768 (0.07008)	Total Volume Flowrate, m ³ /hr	257	344	514	856	1286	1714	2143	2570	3000
		Throw Distance (0.25 m/s), m	<0.35	<0.35	0.35	2.2	6.0	>8.0	>8.0	>8.0	>8.0
		Face Velocity, m/s	1.0	1.4	2.0	3.4	5.1	6.8	8.5	10.2	11.9
		Total Pressure Loss, Pa	<4	<4	4	9	20	33	40	75	90
		Noise Rating (NR)	<10	<10	14	25	33	40	45	48	51
		Temperature Quotient	-	-	-	0.23	<0.14	<0.14	<0.14	<0.14	<0.14
		Induction Ratio	-	-	-	4.3	>7	>7	>7	>7	>7

Exhaust

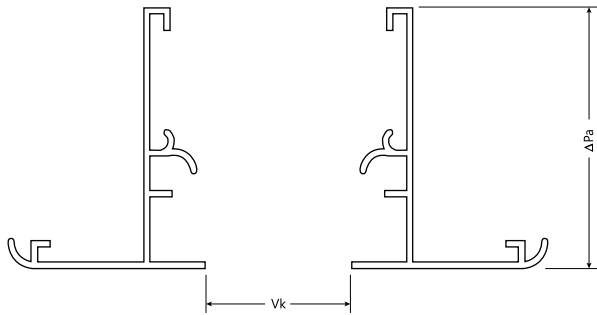

* Performance data recorded in per meter unit length.

* Exhaust air capacity is based on slot diffuser without deflectors. When a pattern deflector is used, the effective area will be reduced by estimated value of 34%.

* The effective area given is to the best estimation & knowledge of Prudentaire's engineers at the point of entry.

Diffuser Size mm	Estimated Effective Area, m ²	Unit Volume Flowrate, m ³ /hr/m Unit Volume Flowrate, l/s/m	<div style="display: flex; justify-content: space-around; font-size: small;"> NR20 NR40 NR50 </div>									
			107 30	143 40	214 60	357 100	536 150	714 200	893 250	1071 300	1250 350	
1 Slot	0.0159	Face Velocity, m/s	1.9	2.5	3.7	6.2	9.4	12.5	-	-	-	
		Total Pressure Loss, Pa	<5	<5	6	17	36	60	-	-	-	
2 Slot	0.0318	Face Velocity, m/s	0.9	1.2	1.9	3.1	4.7	6.2	7.8	9.4	10.9	
		Total Pressure Loss, Pa	<5	<5	<5	<5	10	17	27	36	47	
3 Slot	0.0478	Face Velocity, m/s	0.6	0.8	1.2	2.1	3.1	4.1	5.2	6.2	7.3	
		Total Pressure Loss, Pa	<5	<5	<5	<5	<5	7	12	17	23	
4 Slot	0.0634	Face Velocity, m/s	0.5	0.6	0.9	1.6	2.3	3.1	3.9	4.7	5.5	
		Total Pressure Loss, Pa	<5	<5	<5	<5	<5	6	7	10	13	

Note: For Linear Slot Diffuser (Exhaust), customer to indicate option of :

- 1) With Deflectors (Standard Issue)
- 2) Without Deflectors (Upon Request)



NON STANDARD PRODUCTS

Prudent Aire provide highly customizable product designs to address any onsite woes. Started off as modest contractor firm and progressed to being one of the leading supplier of air handling units in Malaysia, Prudent Aire understands the need of providing flexible grille/diffuser designs without compromising grille performance.

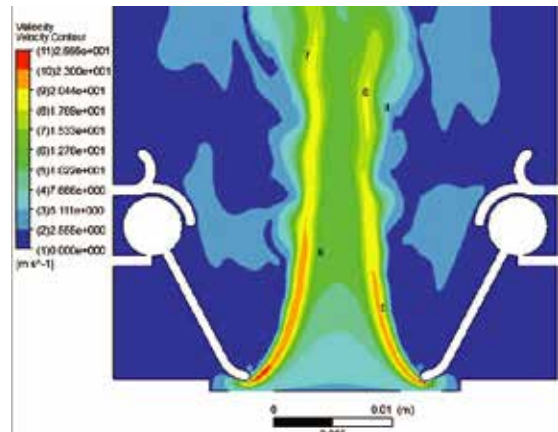
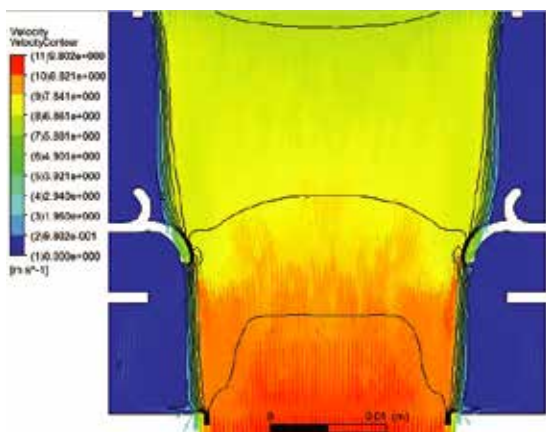

ALUMINIUM LINEAR SLOT DIFFUSERS TECHNICAL SPECIFICATION

Frame Construction

1. Frame to be in extruded aluminium. Frame thickness should be in minimum 1.2mm thick, unless otherwise stated.
2. The margin to be in 28mm from the neck height to the edge.
3. Frame height to be in 40mm.
4. The corner of the frame should be pressed with a 90° corner piece to ensure the frames are in 90°.
5. Diffusers shall be constructed in modular units to be installed in total lengths as required.

Slot Construction

1. Individual slot vane to be had 2 deflector to control air volume and air throw direction.
2. The air throw direction should be able adjust from 90° to 45° in vertical planes at right angles to the slots and should be adjustable from the face of the diffusers.
3. Single slot gap to be with 21mm.

Finishing

1. Finishing should be in powder coated RAL 9010 SG white matt, unless otherwise stated.

Performance

1. Free area of the diffuser is 38%
2. Fixed pattern multi-vanes for directional air distribution.
3. Linear Slot Diffusers are designed to be ceiling mounted, Plenum Box with round duct connection with damper should to be installed at the neck of the diffuser for volume control purpose, unless otherwise stated.
4. Where linear slot return and exhaust inlet devices are used, these shall be similar to the above specifications for diffusers.







DIFFUSER + ACCESSORIES COMBINATION



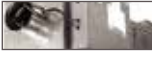

LD | Linear Slot Diffuser

Products Range

- Grilles 
- Diffusers  ◀
- Dampers 
- Fire & Smoke Protection 
- VAV 
- Others 
- Accessories 



Prudent Aire Sdn Bhd 514037-D
 Lot 2102, Jalan KPB12, Off Jalan Suria Park 1, Kg Baru Balakong,
 43300 Seri Kembangan, Selangor Darul Ehsan, Malaysia
 Tel : +603-9100 3858 (HL) / 9101 3869 / 9101 5868
 Fax : +603-9100 4868 Email : sales@prudentaire.com

www.prudentaire.com