

Item No.:

Qty.:

Project:

## MF 750.2 3T Pass Thru

Multi-function Roll-in Blast Chiller and Shock Freezer



MultiFresh®: the blast chiller that organizes your production and processes with flexibility 24 hours a day.

MultiFresh® can run cycles of chilling and freezing with temperatures up to  $-40^{\circ}\text{C}$  preserving the product consistency, the moisture and nutritional properties.

Multifunction 7" touchscreen display, product specific cycles, wide range of options, customization of all the parameters for each cycle.

### Capacity

Trolley Capacity: 6 x GN1/1

3 x GN2/1

6 x 400x600

3 x 800x600

### Yield

Yield for blast chilling cycle ( $+90^{\circ}\text{C}/+3^{\circ}\text{C}$ ) kg 750

Yield for shock freezing cycle ( $+90^{\circ}\text{C}/-18^{\circ}\text{C}$ ) kg 750

### Product Warranty Protection

- 2 years from the date of installation, after sending the installation report, on the parts (see warranty condition)

### Certification



### Standard Construction Features

- Cabinet + Air condensation + remote condenser.
- IRINOX BALANCE SYSTEM®: the perfect sizing of the main components of the refrigeration system (condenser, evaporator, compressor and fans).
- Maximum cleanliness and hygiene due to rounded corners and components situated in the chamber so that they can be easily accessed and cleaned.
- Mechanical locking device with a low temperature resistant gasket.
- Internal and external finishes of the cabinet are in stainless steel AISI 304
- 80 mm thick cabinet panels, insulated with high density polyurethane foam.
- Evaporator fan door can be opened for cleaning and maintenance.
- 5-chamber magnetic door seals with dirt-repellent profile.
- Door frame profiles with anti-moisture resistance.
- Ergonomic mechanical closure handle with internal panic button.
- Multisensor® 5 point probe for perfect temperature control.
- Automatic switch from manual mode (timed) to automatic mode (with probe); Multifresh® senses if the probe has been inserted or not.
- Wireless data transfer (HACCP control software).
- Pass-thru (front door hinged on the right/ back door hinged on the left).
- Sunken floor.
- Drain on the left side (different position on request).
- Refrigerant Gas R452A/R404A

### Unique Design and Performance Features

- STANDARD VERSION: blast chilling and shock freezing cycles from any temperature of the product, to  $+3^{\circ}\text{C}/-18^{\circ}\text{C}$  at the core.
- PLUS VERSION (on request): blast chilling, shock freezing, thawing, holding, chocolate, regeneration, pasteurization, proofing and low temperature cooking. Sanigen® included.
- The touch screen also works when you are using kitchen gloves.
- Manual defrosting at the end of the day (not during the work cycles).

### Option and Accessories

- Opposite doors opening
- Ramps
- No pass-thru (1 door only)
- Ventilated floor (only with ramp)
- Reinforced floor in stainless steel 20/10
- Mirror Unit
- Sous-vide core probe
- Door stop  $100^{\circ}$  and  $120^{\circ}$
- Magnetic door stop  $100^{\circ}$
- Knocked down
- Condensing unit on request: Air condensation + extra low dB remote condenser; Tower water condensation;
- Additional core probe
- SANIGEN®: 24/7 sanitification (already included in the Plus version)
- Low temperature kit (for air condensation only)
- Wifi Mya
- Ethernet board
- Freshcloud connection kit (Ethernet card & wi-fi included)
- Anti-vibration feet for condensing unit
- Dashboard protection IP66
- Frontal/Back door alarm (visual and acoustic)
- Unit sent without gas charge
- Special Voltage on request

## Cabinet

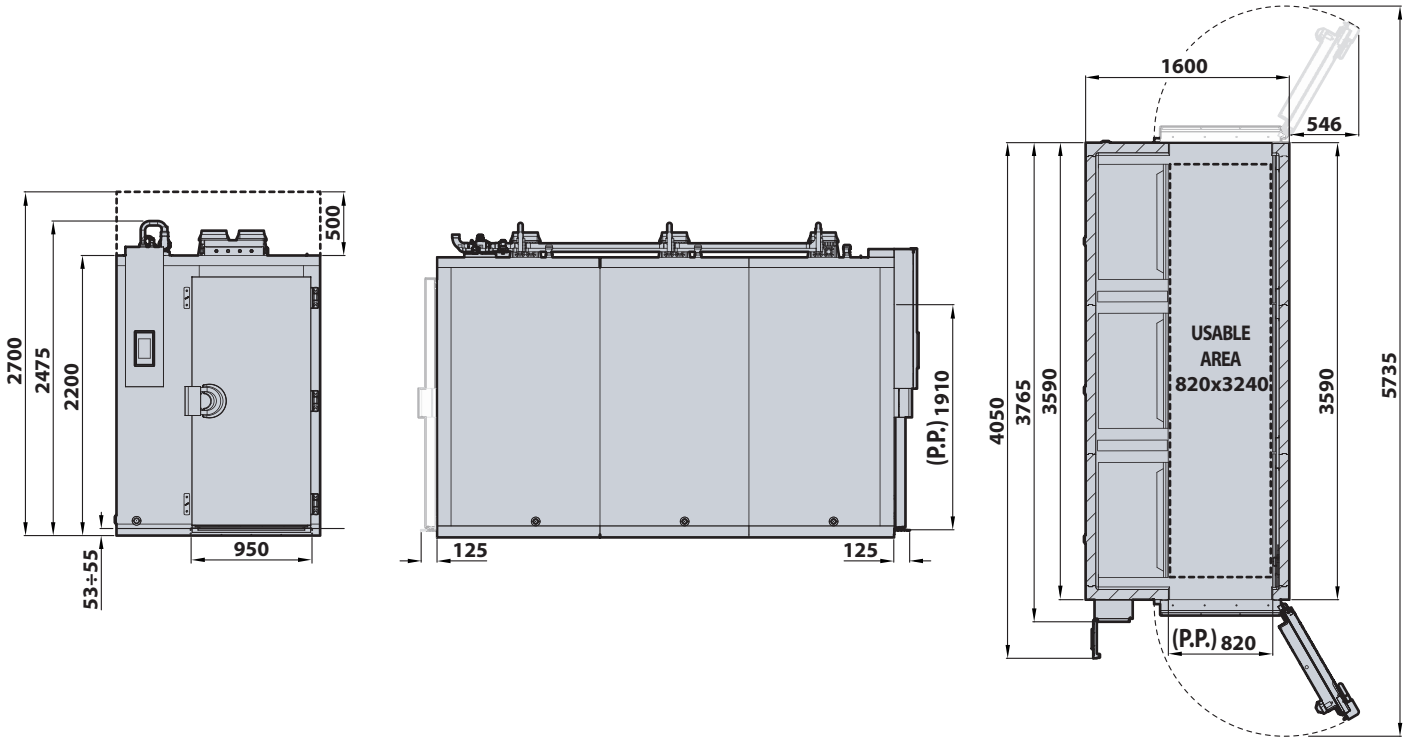

## Unit

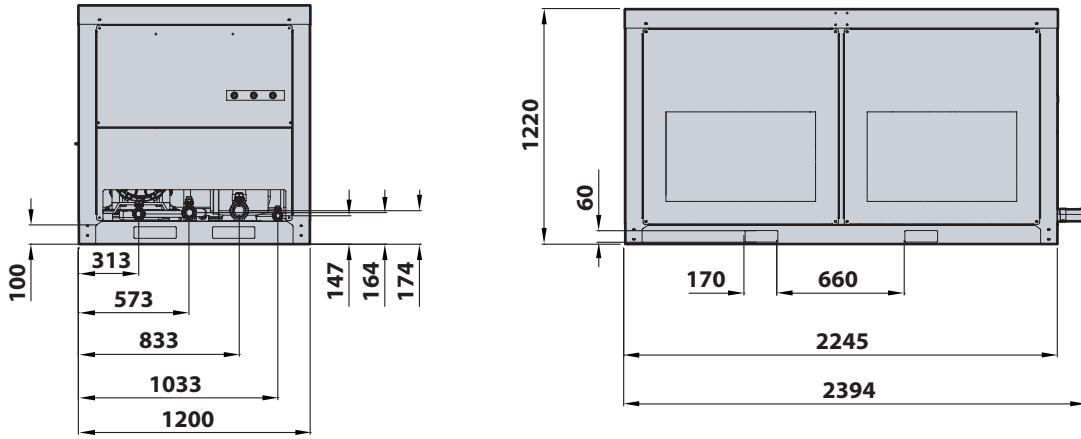

## Condenser

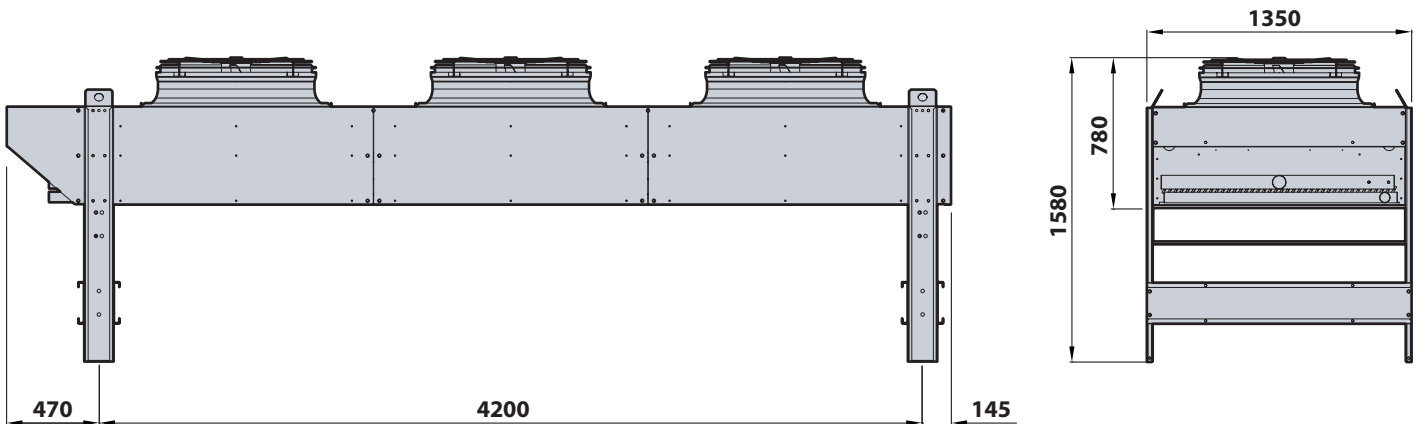

Item No.:

Qty.:

Project:

	Cabinet MF750.2 3T	Unit UC750	Condenser
Dimensions	W. 1600 mm D. 3765 mm H. 2475 mm	W. 1200 mm D. 2245 mm H. 1220 mm	W. 4813 mm D. 1328 mm H. 1387 mm
Pit Dimensions	1610 mm x 3600 mm x 55 mm	-	-
Weight	1200 kg	600 kg	547 kg
<b>Electric Data</b>			
Electric Supply	400V-3N+PE 50Hz	400V-3N+PE 50Hz	-
Full Load Amps (FLA)	Standard 15,50 A / Plus 45,10 A	108,50 A	-
Total Rating (FLI)	Standard 7,10 kW / Plus 30,20 kW	57,40 kW	-
Start Electrical absorption (RLA)	-	226,00 A	-
Compressor Noise	-	72,8 dB(A) 1m	56,0 dB(A) 10m
<b>Key Refrigeration System Data</b>			
Compressor Rating (HP)	-	50	-
Refrigeration Yield (-10°C/40°C) W	-	85700	-
Condensing Rating (-10°C/40°C) W	-	118800	-
Refrigeration Type	-	R452A/R404A	R452A/R404A
Refrigeration Pre-load (kg gas)	-	70,0	-
Maximum Ambient Air Temperature	32°C	42°C	42°C

## INSTALLATION

A detailed installation manual is provided. It must be carefully followed to ensure proper operation and to protect your rights under the warranty.

The connection material between the cabinet and the condensing unit must be provided by the installer.

Continued product development may necessitate specification changes without notice.

## Irinox S.p.A.

Headquarter: Via Caduti nei Lager 1, 31015 Conegliano (TV) Italy  
 Productive Site: Via Mattei, 20 - 31029 - Vittorio Veneto (TV) Italy  
 Tel. +39 0438 2020 | irinox@irinox.com | www.irinoxprofessional.com