



H Series 500 Ice Cube Machine

H Series 500 Ice Cube Machine

Model: HDT0500A-251ZT HYT0500A-251ZT



H500 Ice Machine on H530C Bin

- Up to 244kgs (538lbs) daily ice production and only 30.00" (76.00 cm) wide
- Use R-410A CFC-free refrigerant which lowers global warming potential by 48%
- Easy access front facing evaporator
- All plastic interior, no exposed tubes or wires, smooth rounded corners for fast easy wipe downs
- The food zone is sealed from above and on the back of the door panel with commercial grade rubber gaskets
- Water shield, distribution tube, pump, floats, and trough removable by hand (no tools required). Fast and easy
- Top air discharge, transfers air discharge from the sides of the machine to the top by having the louvered panel on the top of the machine rather than the sides. Re-directs the hot air from the ice machine toward the ceiling rather than directly into the working kitchen environment

Specifications

BTU Per Hour:
5,300 (average), 6,100 (peak)

Compressor:
Nominal Rating: 3/4HP

Refrigerant:
R-410A

Ice Machine Electric
220-240/50/1 standard

Total Circuit Ampacity:

Air Cooled: 6.3A

Power Consumption:

Air Cooled: 1029W

Maximum Fuse Size:15A

HACR-type circuit breakers can be used in place of fuses

Operating Limits:

- Ambient Temperature Range: 1.7°C to 43.3°C
- Water Temperature Range: 1.7°C to 32.2°C
- Water Pressure Ice Maker Water In:
Min. 20 psi (137.9kPa)
Max. 80 psi (551.1kPa)



Cube Size Available



Dice
7/8" X 7/8" X 7/8"
2.22 X 2.22 X 2.22 (cm)





H Series 500 Ice Cube Machine

H500 on H530C Storage Bin

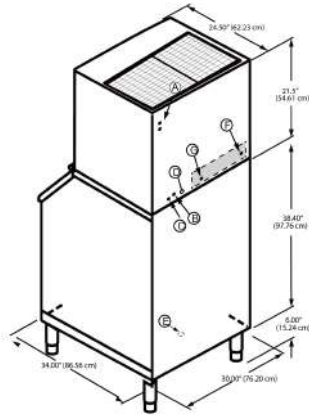

- Ⓐ Electrical Entrance (2) Options
- Ⓑ 3/8" (0.95 cm) F.P.T. Ice Making Water Inlet
- Ⓒ 1/2" (1.27 cm) F.P.T. Ice Making Water Drain
- Ⓓ 1/2" (1.27 cm) Auxillary Base Drain Socket
- Ⓔ 3/4" (1.91 cm) Bin Drain
- Ⓕ 3/8" (0.95 cm) F.P.T. Water Condenser Inlet (water-cooled units)
- Ⓖ 1/2" (1.27 cm) F.P.T. Water Condenser Outlet (water-cooled units)

*Installation Note - Minimum installation clearance:
Sides: 0, Top: 12" (30.5 cm), back: 5" (12.7cm).*

Space-Saving Designs



	H500 H530C
Height	66" 168cm
Width	30.00" 76.20 cm
Depth	34.00" 86.50 cm
Bin Storage	463 lbs 210 kg

Height includes adjustable bin legs 6.00" to 7.00" (15.24 cm to 17.78 cm) set at 6.00" (15.24 cm).

Model	Ice Shape	Ice Production 24 Hours		Power Usage kWh/100 lbs. @90°Air/70°F	Water Usage 100 lbs. 45.4 kgs. of Ice
		70°Air/ 50°F Water	90°Air/ 70°F Water		
HDT0500A-251ZT	dice	214kgs	169kgs	6.64	75.7
		472lbs	372lbs		
HYT0500A-251ZT	half dice	226kgs	178kgs	6.45	75.7
		499lbs	392lbs		

Order ice storage bin separately. Suffix of model "A" means air cooled condenser

Top Air Discharger



Top air discharge, transfers air discharge from the sides of the machine to the top by having the louvered panel on the top of the machine rather than the sides. Re-directs the hot air from the ice machine toward the ceiling rather than directly into the working kitchen environment

Easy Access to Parts of Water System



Water shield, distribution tube, pump, floats, and trough removable by hand

Easy Access to Air Filter



Easy to clean, reusable air filter protects condenser from lint, grease and dust.