



VEGETABLE PREPARATION MACHINE CA-301

Commercial vegetable preparation machine with an hourly output of up to 450 Kg.



FEATURES AND BENEFITS

- ✓ Stainless steel construction and highest quality material, all suitable for contact with food.
- ✓ New production technology that gives a uniform, high-quality cutting result.
- ✓ Ergonomic design: product is sliced/cut/shredded in one single movement.
- ✓ The large range of high quality discs and grids allows the operator to obtain over 70 different styles of product. Discs are not included.
- ✓ Lateral product ejection, reducing the amount of counter space required, whilst also minimising product splashing.
- ✓ This directs the product avoiding splashing.
- ✓ Electronic, user-friendly control board.
- ✓ Easily removable lever and lid for cleaning purposes.
- ✓ NSF-International certified appliance (complying with Hygiene, Cleaning and Food Material regulations).

INCLUDES

- ✓ 1 speed motor block.
- ✓ Regular hopper.

SALES DESCRIPTION

1 speed motor block and a universal attachment.

DYNAMIC PREPARATION
COMMERCIAL VEGETABLE PREPARATION MACHINES



sammic | www.sammic.com
Food Service Equipment Manufacturer

Polígono Basarte, 1. phone +34 943 15 72 36
20720 Azkoitia, Spain sales@sammic.com



Project	Date
Item	Qty
Approved	

product sheet
updated 24/04/2018



VEGETABLE PREPARATION MACHINE CA-301

Commercial vegetable preparation machine with an hourly output of up to 450 Kg.



SPECIFICATIONS

Hourly production: 150 Kg - 450 Kg

Inlet opening: 136 cm²

Disc diameter: 205 mm

Motor speed: 365 rpm

Loading

Single Phase: 550 W

Three phase: 370 W

Noise level (1m.): 70 dB(A)

Background noise: 32 dB(A)

External dimensions (WxDxH)

Width: 389 mm

Depth: 405 mm

Height: 544 mm

Net weight: 21 Kg

Crated dimensions

435 x 430 x 600 mm

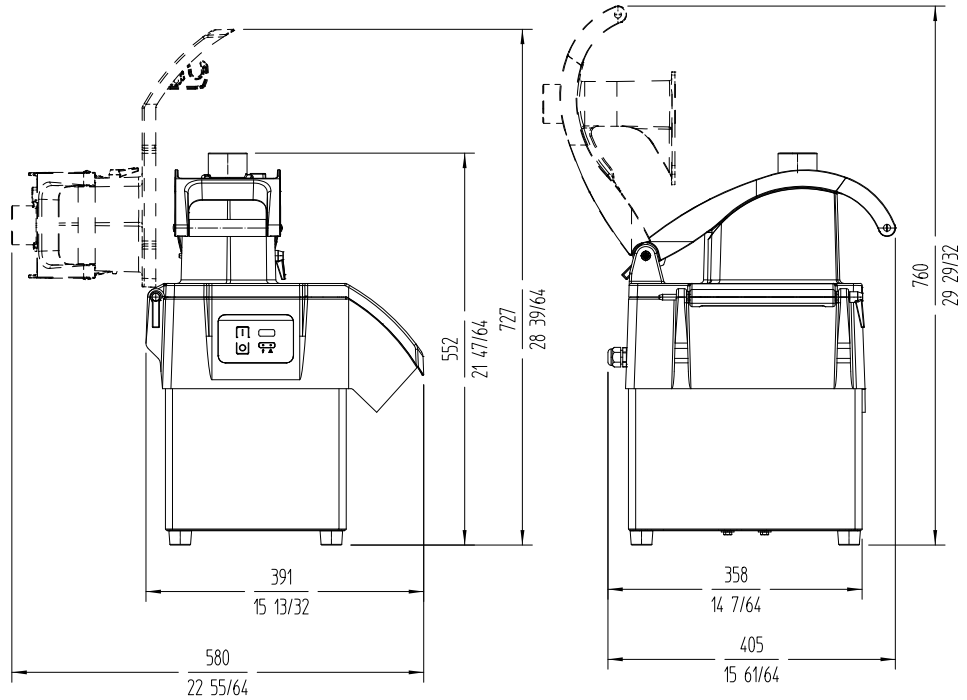

AVAILABLE MODELS

1050301 Vegetable preparation machine CA-301 230-400/50/3N

1050021 Vegetable preparation machine CA-301 230/50/1

* Ask for special versions availability

ACCESSORIES

- FC Slicing Disc
- FCC Curved Slicing Discs
- FCO Rippled Slicing Discs
- FFC Chipping Grids
- FMC Dicing Grids
- FCE Julienne Discs
- FR Shredding & Grating Discs
- Long vegetable attachment
- Universal hopper
- Disc and Grid Holder Device
- Grid Cleaning Kit

DYNAMIC PREPARATION
COMMERCIAL VEGETABLE PREPARATION MACHINES

sammic | www.sammic.com
Food Service Equipment Manufacturer

Polígono Basarte, 1. phone +34 943 15 72 36
20720 Azkoitia, Spain sales@sammic.com



Project	Date
Item	Qty
Approved	

product sheet
updated 24/04/2018