



# VACUUM SEALER SE-604CC

Floorstanding unit. 40m³/h. 465+465 mm.



FOOD PRESERVATION AND SOUS-VIDE  
VACUUM PACKING MACHINES - "SENSOR" LINE



## FEATURES AND BENEFITS

- ✓ Powered by Busch.
- ✓ Vacuum controlled by sensor.
- ✓ Vacuum PLUS.
- ✓ Digital keyboard.
- ✓ Control panel equipped with display indicating the exact vacuum percentage.
- ✓ "Pause" button to marinate food.
- ✓ Safe liquid packing thanks to sensor control.
- ✓ Double seal.
- ✓ Cordless sealing bar.
- ✓ Bag-sealing programme.
- ✓ Pulse-controlled decompression.
- ✓ Vac-Norm ready with Automatic decompression.
- ✓ Stainless steel body and chamber.
- ✓ Damped transparent lid of highly durable polycarbonate.
- ✓ Dry-oil programme for drying the pump.
- ✓ Working hours counter for oil changes.
- ✓ Safety system with protection against vacuum failure.
- ✓ NSF-listed.

## SALES DESCRIPTION

Two sealing bars (465+465 mm.)  
 40 m³/h Busch vacuum pump.  
 Vacuum controlled by sensor.

## INCLUDES

- ✓ Sensor Controls
- ✓ Up to 10 seconds of extra vacuum pull
- ✓ Soft air function
- ✓ Dry oil cycle
- ✓ BUSCH pump
- ✓ NSF Approved
- ✓ Clear methacrylate lid
- ✓ Filling plate



**sammic** | [www.sammic.com](http://www.sammic.com)  
**Food Service Equipment Manufacturer**

Polígono Basarte, 1. phone +34 943 15 72 36  
 20720 Azkoitia, Spain [sales@sammic.com](mailto:sales@sammic.com)



|          |      |
|----------|------|
| Project  | Date |
| Item     | Qty  |
| Approved |      |

product sheet  
 updated 24/04/2018



# VACUUM SEALER SE-604CC

Floorstanding unit. 40m<sup>3</sup>/h. 465+465 mm.



## SPECIFICATIONS

Pump capacity: 40 m<sup>3</sup>/h  
 Bar length: 465 mm + 465 mm  
 Total loading: 1100 W  
 Vacuum pressure (maximum): 0,5 mbar

### Internal dimensions

- ✓ Width: 672 mm
- ✓ Depth: 481 mm
- ✓ Height: 200 mm

### External dimensions (WxDxH)

- ✓ Width: 740 mm
  - ✓ Depth: 566 mm
  - ✓ Height: 997 mm
- Net weight: 145 Kg  
 Noise level (1m.): 75 dB(A)  
 Background noise: 32 dB(A)

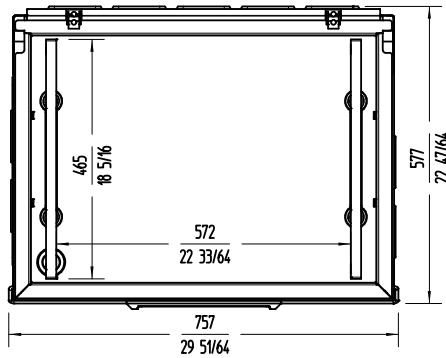
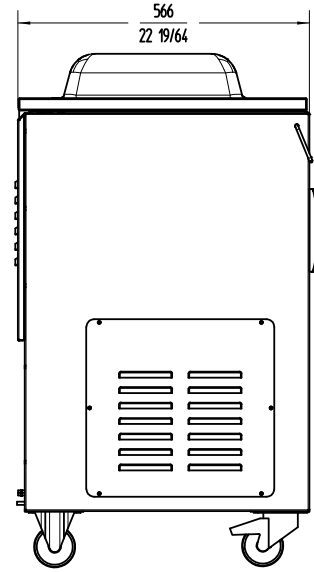
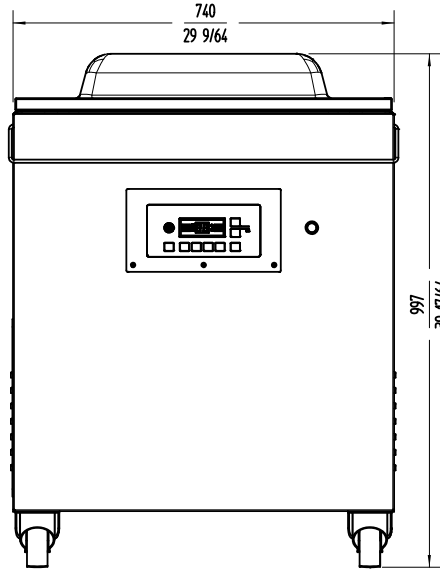

## AVAILABLE MODELS

1140651 Vacuum packing machine SE-604 CC 230-400/50/3N

\* Ask for special versions availability

## ACCESSORIES

- Bag cutting kits
- Vac-norm external vacuum kits
- Filling plates
- Vac-norm containers
- Liquid insert plates
- Smooth bags for vacuum packing

FOOD PRESERVATION AND SOUS-VIDE  
VACUUM PACKING MACHINES - "SENSOR" LINE

**sammic** | www.sammic.com  
 Food Service Equipment Manufacturer

Polígono Basarte, 1. phone +34 943 15 72 36  
 20720 Azkoitia, Spain sales@sammic.com



|          |      |
|----------|------|
| Project  | Date |
| Item     | Qty  |
| Approved |      |

product sheet  
updated 24/04/2018