



CAST IRON SOIL PIPES & FITTINGS
 Hubless Type
 CISPI 301
 ASTM A 888



FLOOR DRAINS
ROOF DRAINS
FLOOR CLEAN-OUT etc.



ACCESSORIES

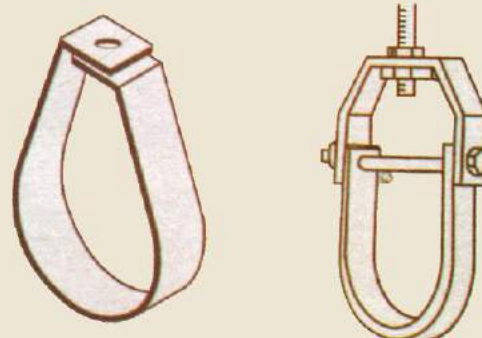

SUMMARIZED PLANT HISTORY

TCP THAI CAST MANUFACTURING LTD., PART. was established in 1967. Being continuous manufacturers for over 30 years, TCP THAI CAST MANUFACTURING LTD., PART. have constantly been confided to the satisfactory quality of production and supplyment. Thanks to careful quality control. "TCP" Cast Iron Soil Pipes & Fittings have been "Product of confidence" in both our territory and foreign countries, in government and private work extent, and this contributes eventual growth to our plant. Until now, TCP THAI CAST MANUFACTURING LTD., PART. obtain the highest production capacity of Cast Iron Soil Pipes & Fittings in Thailand.

Since 1971, a number of our associated plants have been set up in addition for manufacture of other products for plumbing and sanitary works as following:

- Floor /Roof Drains Floor Clean-Out etc.
- Brass Cocks & Bronze Gate Valves.
- Coated Sand for Foundry Use.
- PVC Pipes & Fittings.
- Stainless Fittings.
- Teflon Thread Sealing Tapes & PTFE Gaskets.
- Sanitary Ware.

DETAILS ON TCP THAI CAST MANUFACTURING LTD., PART

	1967 -1972	1993
AREA	16,800 Sq. Meter	42,200 Sq. Meter
NUMBER OF WORKERS	40-60 workers	350 workers
CAPACITY PER YEAR	150 M/T	1,200 M/T
SIZE OF OUR PRODUCT	2" - 6"	2" - 6"
SUPPLYMENT	Local Market	Local Market & Other Foreign Countries Such as U.S.A., Japan, Malaysia, Brunei, Singapore etc.

Cast iron is introduced because of its strength and easy installation. It is now top of the list for owners, developers and contractors. Regardless of project types and specifications, we guarantee that you will have the following advantages:-

- **THE CLEAR CUT WINNER**
Detailed comparison why TCP Hubless pipe system is a winner.
- **LOW THERMAL EXPANSION**
Cast iron pipes expand and contract at low rate similar to those of building materials such as steel, concrete and masonry, eliminating the need for costly expansion joints.
- **SUPERIOR NOISE SUPPRESSION**
Cast iron soil pipe has been proven by laboratory tests to have a superior noise suppression characteristic.
- **AGAINST CORROSION**
Studies have also shown that cast iron soil pipe provides great resistance to commonly used corrosive chemicals.
- **AGAINST FIRE**
Cast iron exceeds the standard requirements. It can be used to penetrate fire separations without the need for costly devices, and will not produce large quantities of toxic gases in a fire situation.
- **HIGH RIGIDITY**
Overall, no other drainage materials come close to cast iron soil pipe for rigidity and ability to maintain dimensional stability.
- **COST & CONVENIENCE**
It is so easy to assemble that it cuts down installation time and cost.

THE CLEAR CUT WINNER

SL. NO.	PROPERTY	ASBESTOS CEMENT	SWR PVC PIPES	SAND CAST C.I. PIPES	TCP C.I. PIPES
1.	Impact Strength	Low	Minimum	Good	High Strength
2.	Durability	1-4 Years	4-5 Years (After Which It Becomes Brittle)	20 Years	Lifelong
3.	Inside Bore	Not Very Smooth	Smooth	Rough	Very Smooth
4.	Choking	Frequent Choking	No Choking	Frequent Choking	No Choking
5.	Maintenance	Frequent Maintenance	Less Maintenance	Frequent Maintenance	No Maintenance
6.	Repair	Repair Not Possible	Repair Not Possible	Not Easy To Repair	No Repair Required
7.	Installation Time	High	Low	High	Minimum
8.	Conforms To International Standard	No	No	No	DIN/ISO/CISPI 301
9.	Resistance To Fire and Heat	Low	Very Low	Good	Good
10.	Resale Value	No	No	Yes	Yes

LOW THERMAL EXPANSION

Allowance for expansion and contraction of building materials is an important consideration in any situation where construction is often undertaken in different temperatures. Once a building is "closed in" and reaches normal indoor temperatures, the building materials expand or contract.

Table for expansion of common building materials.

MATERIAL	Linear expansion in 100 ft. (30.48m) of pipe for a temperature rise of 100°F (55.5°C)
Brick	0.64 Inch. (16.26mm)
Cast Iron	0.71 Inch. (18.03mm)
Abestos-cement	0.72 Inch. (18.29mm)
Steel	0.73 Inch. (18.54mm)
Concrete	0.74 Inch. (18.80mm)
Copper	1.10 Inch. (27.94mm)
Aluminium	1.54 Inch. (39.12mm)
PVC	3.50 Inch. (88.90mm)
ABS	6.70 Inch. (170.18mm)

Note that cast iron expands at approximately the same amount as brick, steel and concrete. Cast iron pipe expands 0.71 inches in 100 feet at a temperature rise of 100°F. (18.03mm in 30.48m at temperature rise of 55.5°C)

We in TCP make pipes to meet the World's conditions.

SUPERIOR NOISE SUPPRESSION

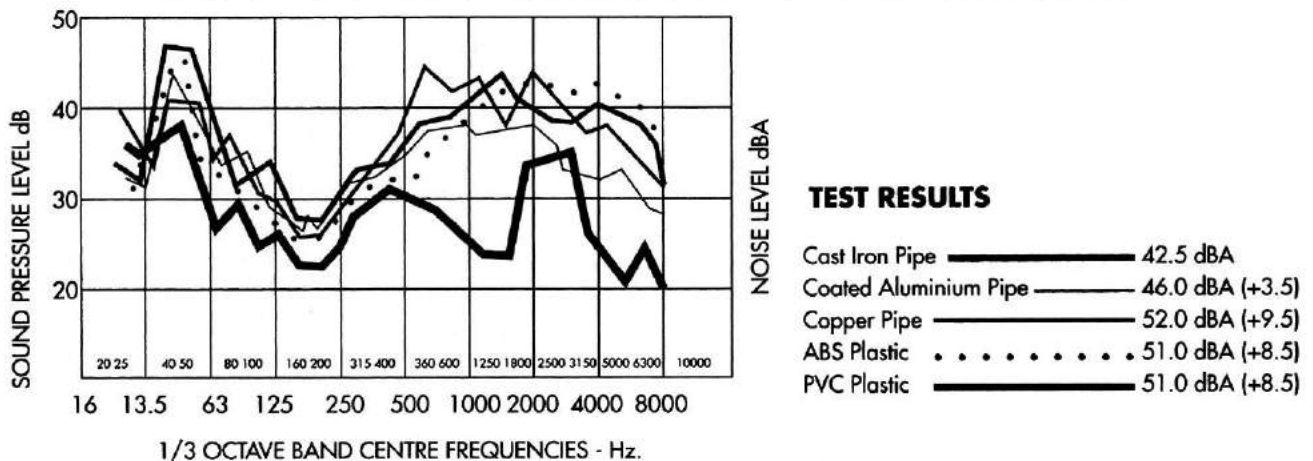

The illustrated chart above shows that cast iron pipe noise level is significantly lower than the other specimens. The "A" scale reading and the differences compared to cast iron pipe are quite significant. A difference of 3 dB is distinctly noticeable. A difference of 10 dB is considered to be doubling subjective loudness. The actual difference in sound power output compared to cast iron is approximately 2¼ times for aluminium, 7 times for plastic and 9 times for copper.

The tests above were conducted using 10 feet section of pipe. Sound output differences between cast iron and other materials could be expected to be much greater in longer pipe runs in high-rise office or apartment construction.

AGAINST CORROSION

History proves that Cast Iron soil pipes and fittings resist corrosion from solutions commonly found in drain, waste and vent systems. Many installations are still in use after more than a century of continuous service. Natural qualities of cast iron make it the ideal material for drain, waste and vent use-without additional linings or coatings.

There was a study, made to test the superiority of cast iron against chemical. These chemicals were poured into the test system and held for 1 hour intervals for a period of 4 weeks.

- 5% Acetic Acid
- 0.1 N Sulphuric Acid
- 0.2 N Sodium Hydroxide
- 5% Sodium Chloride
- 5% Kerosene
- 5% Household Detergent
- 5% Sodium Hypochlorite (bleach)

- **TEST RESULTS**

The results were: There were no significant corrosion observed on the cast iron pipe over the test period. However, the other materials showed definite signs of pitting corrosion on the joint area of the pipe.

- **NATURAL CORROSION RESISTANCE**

In the laboratory and through more than a century of actual use, cast iron soil pipe has been proven as the best material to withstand corrosion. You can rely on cast iron with confidence because its natural qualities of corrosion resistance makes it the best.

- **HOT WATER RESISTANT**

Discharge of superheated water from commercial, industrial or residential appliances will not affect cast iron pipe.

- **ENVIRONMENT FRIENDLY**

TCP cast-iron centrifugal spun pipes are absolutely environmental friendly and 95% of the material can be recycled.

AGAINST FIRE

Fire rated construction is one important thing to look into; to ensure the safety of building occupants. It requires the integrity of a fire separation be maintained for up to two hours during blaze. Because cast iron soil pipes which penetrate fire separations will not allow the passage of flames from one compartment to another, fire retardants and cut off devices are not required.

Some drain, waste and vent materials produce large quantities of deadly hydrogen cyanide or hydrogen chloride gas, even when exposed only to relatively low temperatures near a fire area. Noncombustible cast iron soil pipe will not produce toxic gases even when directly involved in a fire.

Our pipes can withstand temperatures up to 600°C without distortion.

HIGH RIGIDITY

Tests were conducted to prove rigidity over four other common types of three inches (75mm) diameter pipe. Results as shown below.

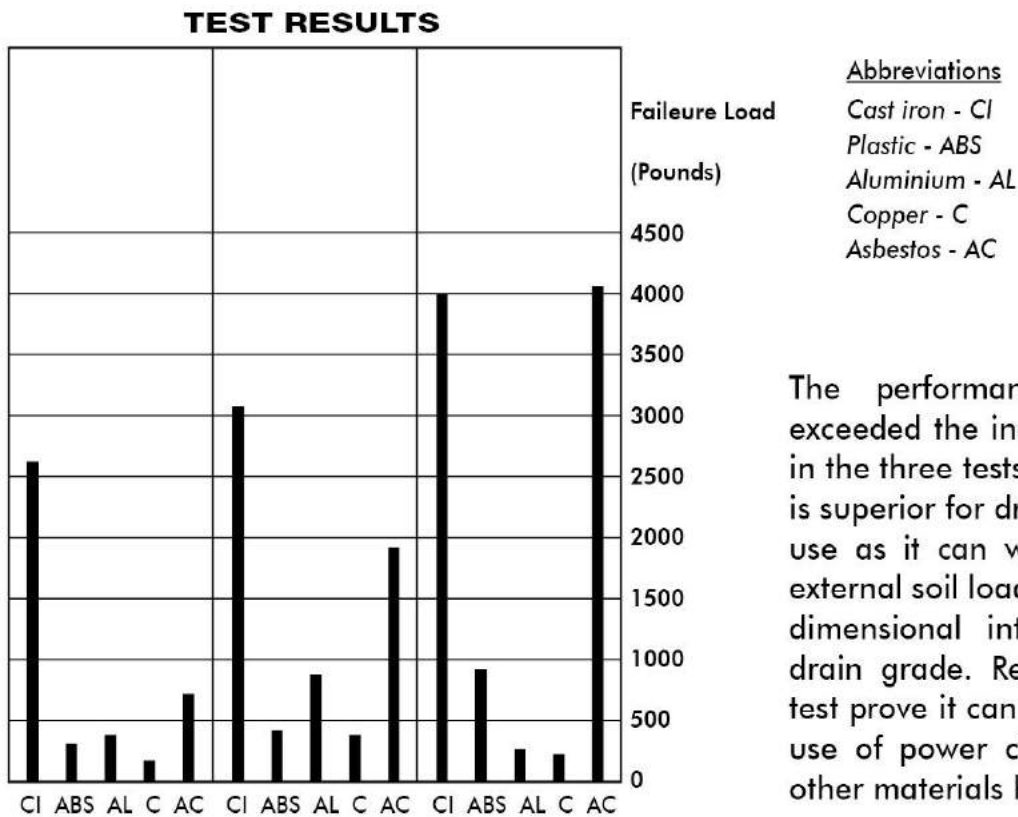

The performance of cast iron exceeded the industry requirements in the three tests. Cast iron soil pipe is superior for drain, waste and vent use as it can withstand significant external soil loads while it maintains dimensional integrity and proper drain grade. Results of the pierce test prove it can withstand repeated use of power cleaning tools while other materials have failed.

COST & CONVENIENCE

WHY WE ARE CONVENIENT

1. Save time and money by taking advantage of the simple and easy method to install stainless steel coupling.
2. The centrifugal process ensures the uniform thickness in the pipes. As such, there will be no cutting wastage.
3. The centrifugal process ensures the cast pipe to have high density and close grains, thus eliminating porosity - the cause of leakages.
4. Few tools are required to make a joint - a spanner is all you need. No molten lead or soldering is required and toxic glues or solvents are eliminated.
5. TCP Brand has produced a number of combination fittings which combine two or more fittings into a single unit. This provides for less labour, less possibility of leakage and more rigidity.
6. Should there be any removal or rotating of a fitting be required after the initial installation, simply remove or loosen the necessary couplings. Alterations or additions can be quickly and easily made with minimum interruption to your work process.
7. Cleaning of cast iron plumbing system can be undertaken with push rods or sharp cutting tools without damage to the product. There is no need to worry about the use of harsh chemicals.
8. Because of the rigidity of the cast iron pipe, fewer hangers are required when suspending pipe. There is no tendency for drain lines to sag between supports.

CERTIFICATION



No Lesen : LN012901
Licence No :

SIJIL BARANGAN TERSENARAI

Product Listing Certificate



SIRIM QAS International Sdn. Bhd. dengan ini menganugerahkan kepada
SIRIM QAS International Sdn. Bhd. hereby grants to

NORWARDS ENGINEERING (M) SDN. BHD.
LOT 5191 JALAN BALAKONG
BATU 13, TAMAN BALAKONG JAYA
43300, BALAKONG
SELANGOR, MALAYSIA

Sijil untuk menggunakan Tanda Barangan Tersenarai
a certificate to use the Listed Product Mark on

**HUBLESS CAST IRON SOIL PIPE FOR SANITARY AND STORM DRAIN,
WASTE AND VENT PIPING APPLICATION**

Please refer to detail in the SCHEDULE

sebagai mematuhi keperluan
as complying with
CISPI 301 - 1995



Khalidah Mustafa
Pegarah Urusan
Managing Director
SIRIM QAS International Sdn. Bhd.

SIRIM QAS International Sdn. Bhd.
No. Syarikat 81020-A
1, Persiaran Damai Menteri
Selatan 2, F&B Damai 755
43700 Batu Alam
Selangor Darul Ehsan
MALAYSIA.

Tel: 60-3-5544840
Fax: 60-3-5544840
http://www.sirim.com.my
http://www.sirimqas.com.my

Tarikh Mula Penilaian : 25 January 2002
Certified Since

Sah Sehingga : 25 January 2014
Valid Until

Tarikh Dikeluarkan : 20 December 2012
Issue Date

No Siri : 000787
Serial No

Lesen ini dianugerahkan terutamanya kepada syarikat-syarikat Pendaftaran Penilaian Barangan SIRIM QAS International Sdn. Bhd.
This Licence is granted subject to the provisions of the Product Certification Agreement of SIRIM QAS International Sdn. Bhd.



No Lesen : LN012902
Licence No :

SIJIL BARANGAN TERSENARAI

Product Listing Certificate



SIRIM QAS International Sdn. Bhd. dengan ini menganugerahkan kepada
SIRIM QAS International Sdn. Bhd. hereby grants to

NORWARDS ENGINEERING (M) SDN. BHD.
LOT 5191 JALAN BALAKONG
BATU 13, TAMAN BALAKONG JAYA
43300, BALAKONG
SELANGOR, MALAYSIA

Sijil untuk menggunakan Tanda Barangan Tersenarai
a certificate to use the Listed Product Mark on

**HUBLESS CAST IRON SOIL FITTING FOR SANITARY AND STORM DRAIN,
WASTE AND VENT PIPING APPLICATION**

Please refer to detail in the SCHEDULE

sebagai mematuhi keperluan
as complying with
CISPI 301 - 1995



Khalidah Mustafa
Pegarah Urusan
Managing Director
SIRIM QAS International Sdn. Bhd.

SIRIM QAS International Sdn. Bhd.
No. Syarikat 81020-A
1, Persiaran Damai Menteri
Selatan 2, F&B Damai 755
43700 Batu Alam
Selangor Darul Ehsan
MALAYSIA.

Tel: 60-3-5544840
Fax: 60-3-5544840
http://www.sirim.com.my
http://www.sirimqas.com.my

Tarikh Mula Penilaian : 25 January 2002
Certified Since

Sah Sehingga : 25 January 2014
Valid Until

Tarikh Dikeluarkan : 20 December 2012
Issue Date

No Siri : 000788
Serial No

Lesen ini dianugerahkan terutamanya kepada syarikat-syarikat Pendaftaran Penilaian Barangan SIRIM QAS International Sdn. Bhd.
This Licence is granted subject to the provisions of the Product Certification Agreement of SIRIM QAS International Sdn. Bhd.



No Lesen : LN012901
Licence No :

SCHEDULE

NORWARDS ENGINEERING (M) SDN. BHD.



Brand : TCP
Model : CAST IRON PIPE WITHOUT SPIGOT BEAD
Rating : LAYING LENGTH : 10FT. NOMINAL SIZE : 2", 3", 4", 6" AND 8".
PIPE JOINTS PASSED THE HYDROSTATIC, DEFLECTION AND SHEAR TESTS
TO APPENDIX A OF CISPI 310-96, WHEN ASSEMBLED WITH THE TCP SLEEVE-
TYPE COUPLING. (REPORT NO. 2001CB0925).

Factory Name and Location :
TCP THAI CAST MANUFACTURING LTD. PART.
48 SETTAKIT
1 ROAD
74110, TAMAI KRATUMBAN
SAMUTSAKORN, THAILAND

End of page

SIRIM QAS International Sdn. Bhd.
No. Syarikat 81020-A
1, Persiaran Damai Menteri
Selatan 2, F&B Damai 755
43700 Batu Alam
Selangor Darul Ehsan
MALAYSIA.

Tel: 60-3-5544840
Fax: 60-3-5544840
http://www.sirim.com.my
http://www.sirimqas.com.my

Tarikh Mula Penilaian : 25 January 2002
Certified Since

Sah Sehingga : 25 January 2014
Valid Until

Tarikh Dikeluarkan : 20 December 2012
Issue Date

No Siri : 000787
Serial No

Lesen ini dianugerahkan terutamanya kepada syarikat-syarikat Pendaftaran Penilaian Barangan SIRIM QAS International Sdn. Bhd.
This Licence is granted subject to the provisions of the Product Certification Agreement of SIRIM QAS International Sdn. Bhd.



No Lesen : LN012902
Licence No :

SCHEDULE

NORWARDS ENGINEERING (M) SDN. BHD.



Brand : TCP
Model : CAST IRON FITTINGS WITH SPIGOT BEADS AND POSITIONING LUGS.
Rating : P-TRAP (2, 3 & 4);
ALL DIMENSIONS ARE IN INCHES.
Rating : 1/4 BEND (2, 3, 4, 6 & 8); 1/8 BEND (2, 3, 4, 6 & 8); LONG SWEEP BEND(2, 3 & 4).
ALL DIMENSIONS ARE IN INCHES.
Rating : SANITARY TEE, SINGLE (2, 3, 3X2, 4, 4X2, 4X3, 6, 6X2, 6X3, 6X4, 8, 8X4 & 8X6)
ALL DIMENSIONS ARE IN INCHES.
Rating : COMBINATION TEE AND 1/8 BEND, SINGLE (2, 3, 3X2, 4, 4X2, 4X3, 6, 6X2, 6X3, 6X4, 8, 8X4 & 8X6)
ALL DIMENSIONS ARE IN INCHES.

Factory Name and Location :
TCP THAI CAST MANUFACTURING LTD. PART.
48 SETTAKIT
1 ROAD
74110, TAMAI KRATUMBAN
SAMUTSAKORN, THAILAND

End of page

SIRIM QAS International Sdn. Bhd.
No. Syarikat 81020-A
1, Persiaran Damai Menteri
Selatan 2, F&B Damai 755
43700 Batu Alam
Selangor Darul Ehsan
MALAYSIA.

Tel: 60-3-5544840
Fax: 60-3-5544840
http://www.sirim.com.my
http://www.sirimqas.com.my

Tarikh Mula Penilaian : 25 January 2002
Certified Since

Sah Sehingga : 25 January 2014
Valid Until

Tarikh Dikeluarkan : 20 December 2012
Issue Date

No Siri : 000788
Serial No

Lesen ini dianugerahkan terutamanya kepada syarikat-syarikat Pendaftaran Penilaian Barangan SIRIM QAS International Sdn. Bhd.
This Licence is granted subject to the provisions of the Product Certification Agreement of SIRIM QAS International Sdn. Bhd.

**DIMENSIONS AND TOLERANCES (IN INCHES) OF SPIGOTS
AND BARRELS 4 FOR HUBLESS PIPE AND FITTINGS (CISPI 301)**

Pipe Size	Inside Diameter Barrel	Outside Diameter Barrel	Thickness of Barrel		Laying Length L	
	B	J	T-Norm	T-Min	5 Foot (f. 25)	10 Foot (f. 50)
2	2.00 ± .06	2.35 ± .09	0.16	0.13	60	120
3	3.00 ± .06	3.35 ± .09	0.16	0.13	60	120
4	4.00 ± .06	4.38 ± .09 - .05	0.19	0.15	60	120
6	5.94 ± .09	6.30 ± .09 - .05	0.19	0.15	60	120
8	7.94 ± .13	8.38 ± .13 - .09	0.23	0.17	60	120

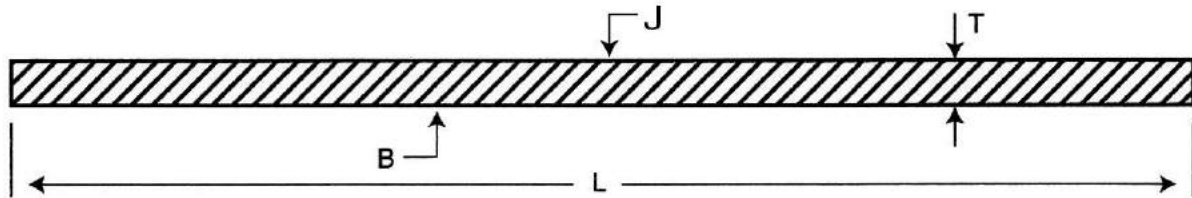

PIPES & COUPLING

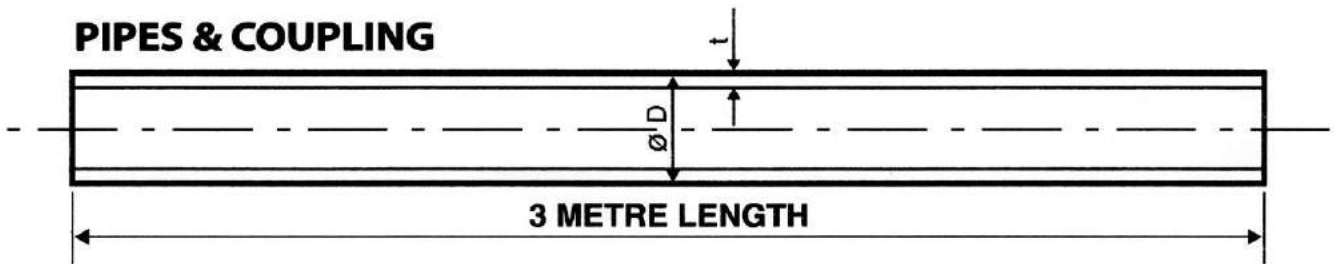

PIPES WITH PLAIN ENDS (Manufacturer Specification)

Dimensions in mm.

SIZE (Inches)	D	t.	Approx. Mass kg
2	57	4.5	18.0
3	83	5	22.5
4	109	5	27.3
6	161	6	46.4
8	219	7	82.0

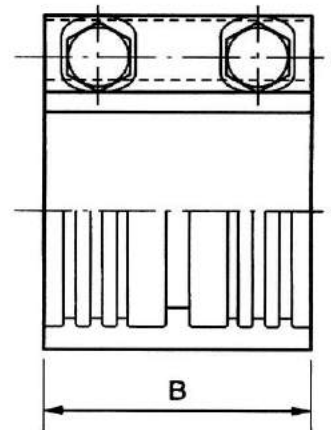
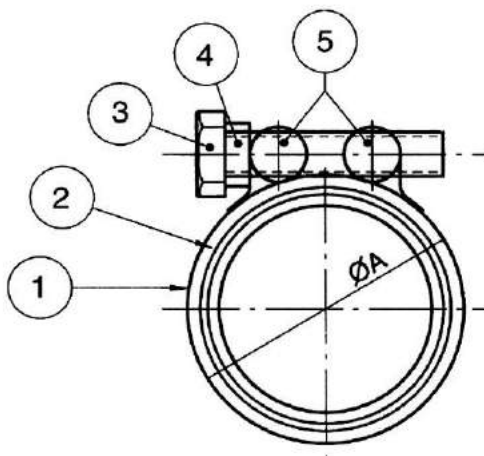

COUPLING

Dimensions in mm.

No.	Item	Material	Pcs
1	Collar	Stainless	1
2	Rubber Sleeve	Neoprene	1
3	Nut Screw	Stainless	2
4	Washer	Stainless	2
5	Shaft	Stainless	2

Nominal Size A	B	Mass (kg)
2"	54	0.22
3"	54	0.29
4"	54	0.32
6"	65	0.42
8"	90	0.85

FITTINGS

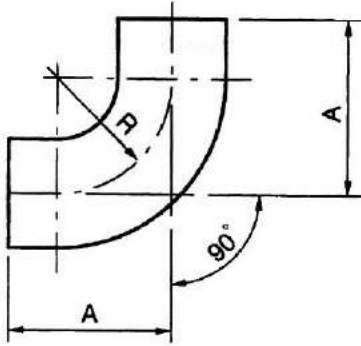

90°(1/4) BEND

Dimensions in mm.

SIZE (Inches)	A	R	Mass (kg)
2	75	48	0.71
3	95	63	1.87
4	140	102	3.60
6	145	127	5.88
8	175	152	14.5

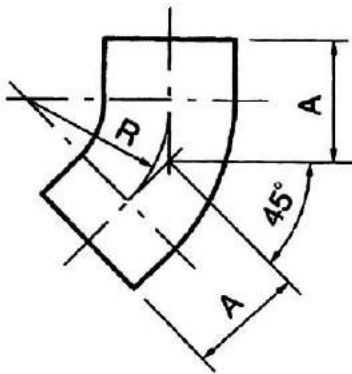

45°(1/8) BEND

Dimensions in mm.

SIZE (Inches)	A	R	Mass (kg)
2	50	48	0.60
3	60	63	1.20
4	79	102	2.29
6	90	127	4.45
8	110	152	10.00

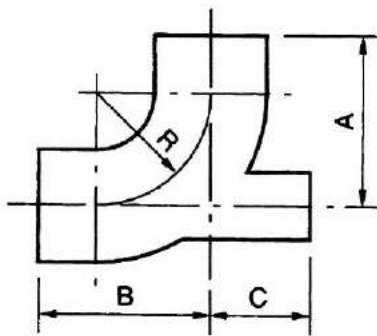

90°(1/4) BEND with HEEL INLET

Dimensions in mm.

SIZE (Inches)	A	B	C	R	Mass (kg)
3 x 2	127	127	73	89	2.39
4 x 2	140	140	83	102	4.12

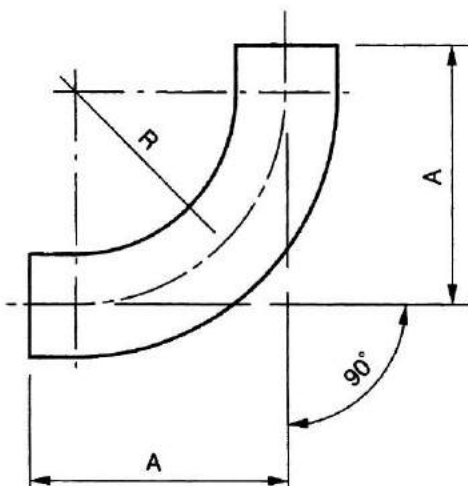

90°(1/4) LONG SWEEP BEND

Dimensions in mm.

SIZE (Inches)	A	R	Mass (kg)
2	241	203	2.66
3	254	216	4.60
4	267	229	6.56
6	310	272	9.60

FITTINGS

45° Y BRANCHES, SINGLE & DOUBLE

Dimensions in mm.

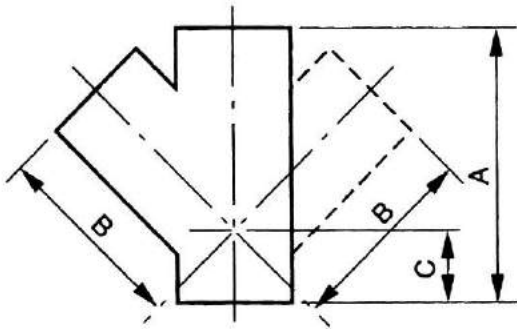

SIZE (Inches)	A	B	C	Mass (kg) Single	Mass (kg) Double
2	160	115	45	1.42	1.90
3	215	115	60	3.19	4.30
4	260	190	70	4.78	6.75
6	355	265	90	10.47	14.63
8	455	340	140	23.10	-
3 x 2	180	135	45	2.14	3.80
4 x 2	168	152	25	2.83	3.05
4 x 3	220	170	50	3.89	6.50
6 x 2	211	210	13	5.40	8.80
6 x 3	245	222	32	6.60	8.80
6 x 4	280	225	55	8.03	9.00
8 x 4	300	260	40	15.13	20.00
8 x 6	375	300	75	20.00	-

90° SANITARY T BRANCHES, SINGLE & DOUBLE

Dimensions in mm.

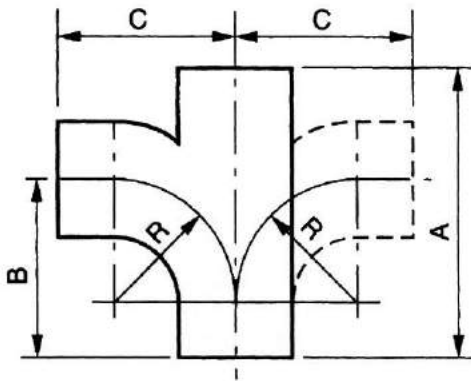

SIZE (Inches)	A	B	C	R	Mass (kg) Single	Mass (kg) Double
2	175	114	114	76	1.38	1.50
3	203	127	127	89	3.00	3.82
4	232	140	140	102	4.73	5.80
6	300	165	165	115	7.78	9.57
8	377	212	212	152	21.00	-
3 x 2	175	114	127	76	2.38	4.00
4 x 2	175	114	140	76	3.29	3.40
4 x 3	203	127	140	89	3.85	5.70
6 x 2	208	127	165	76	4.90	8.20
6 x 3	232	140	165	89	5.96	5.10
6 x 4	256	152	165	76	7.66	8.39
8 x 4	276	162	192	102	12.00	-
8 x 6	328	187	202	127	15.50	14.60

45° COMBINATION & 1/8 BEND, SINGLE & DOUBLE

Dimensions in mm.

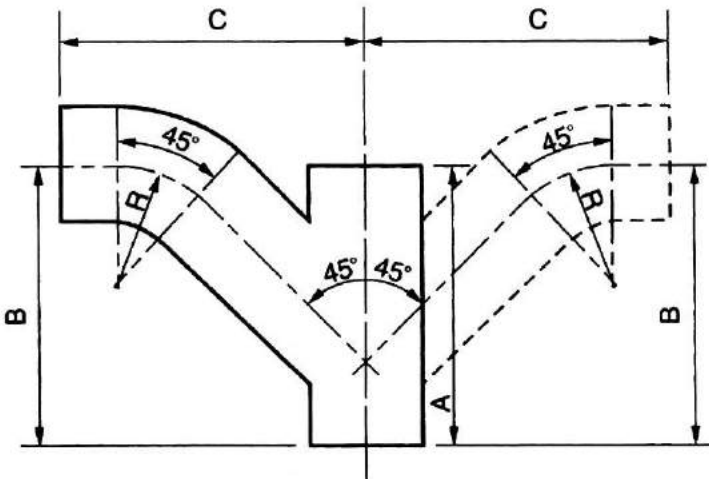

SIZE (Inches)	A	B	C	R	Mass (kg) Single	Mass (kg) Double
2	168	137	156	76	1.76	2.70
3	203	186	203	89	4.00	6.25
4	241	235	254	102	7.62	10.90
6	357	346	365	127	14.93	25.10
8	430	375	395	152	34.50	-
3 x 2	168	140	171	76	2.70	4.50
4 x 2	168	140	184	76	5.11	10.10
4 x 3	203	184	216	89	5.30	11.94
6 x 2	211	152	210	76	5.50	-
6 x 3	284	198	241	89	7.50	-
6 x 4	284	248	297	102	10.00	12.50
8 x 4	284	240	287	102	25.15	34.00
8 x 6	354	305	340	127	27.70	33.65

FITTINGS

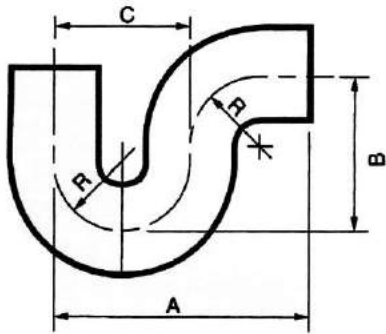

P TRAP

Dimensions in mm.

SIZE (Inches)	A	B	C	R	Mass (kg)
2	191	102	102	51	2.26
3	229	140	127	64	5.07
4	267	165	152	76	8.11
4 x 3	365	150	185	90	8.00

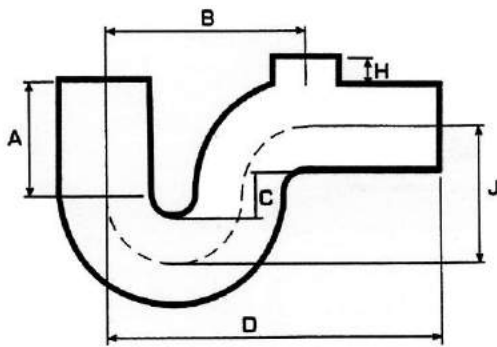

4 x 4 x 2 'P' Trap

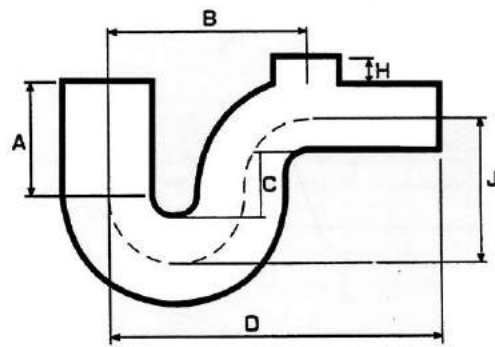

4 x 3 x 2 'P' Trap

'P' TRAP

Dimensions in mm.

SIZE (Inches)	A	B	C	D	J	H	Mass (kg)
4 x 4 x 2 Hubless 'P' Trap	95	225	75	340	180	55	9.10
4 x 3 x 2 Hubless 'P' Trap	85	238	53	365	156	55	8.50

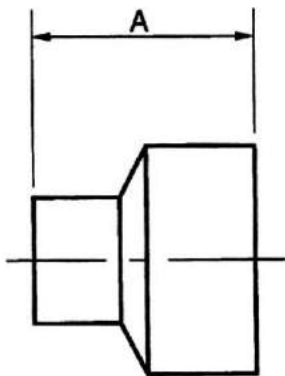

REDUCER

Dimensions in mm.

SIZE (Inches)	A	Mass (kg)
3 x 2	95	0.92
4 x 2	102	1.31
4 x 3	102	1.52
6 x 3	102	2.23
6 x 4	102	2.46
8 x 4	230	7.10
8 x 6	230	14.00

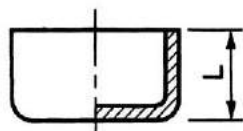

CLEANOUT PLUG

Dimensions in mm.

SIZE (Inches)	L	Mass (kg)
2	30	0.20
3	35	0.37
4	40	0.90
6	50	1.80
8	55	4.30

FITTINGS

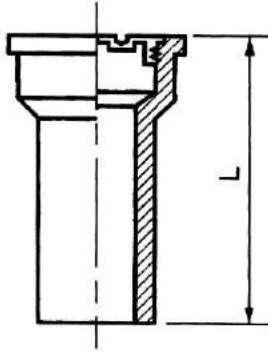

CLEANOUT

Dimensions in mm.

SIZE (Inches)	L	Mass (kg)
2	204	1.52
3	204	2.74
4	204	3.76
6	210	6.09
8	230	10.16

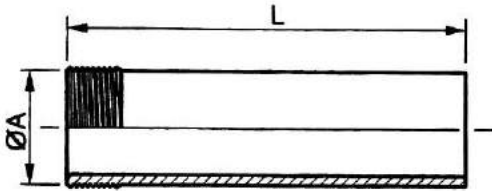

MALE THREAD ADAPTER

Dimensions in mm.

SIZE (Inches)	A	L	Mass (kg)
2	PT 2"	203	1.19
3	PT 3"	203	2.30
4	PT 4"	203	3.09
6	PT 6"	207	3.93
8	PT 8"	230	7.80

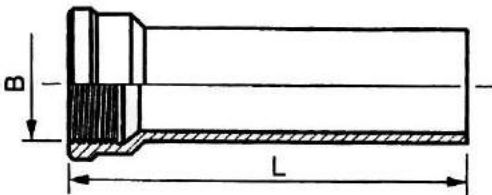

FEMALE THREAD ADAPTER

Dimensions in mm.

SIZE (Inches)	B	L	Mass (kg)
2	PT 2"	203	1.25
3	PT 3"	203	2.35
4	PT 4"	203	3.29
6	PT 6"	207	5.62
8	PT 8"	230	-

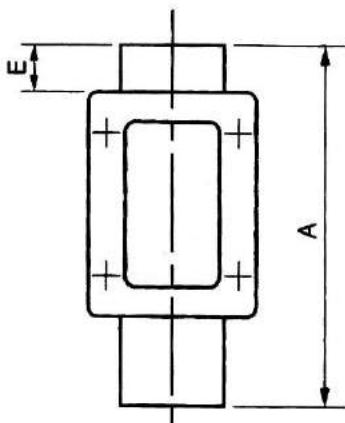

STRAIGHT INSPECTION PIECES with RECTANGULAR ACCESS DOOR

Dimensions in mm.

SIZE (Inches)	A	E	Mass (kg)
3	415	60	10.80
4	420	60	13.54
6	540	70	-
8	593	75	-

CUTTING TECHNIQUES



TCP pipes can be easily and quickly cut using either of the following methods. It should be ensured that the cut ends are square and any burrs removed. It should also be ensured that whatever cutting method is used, it complies with all relevant health and safety regulations and also with the safety guidelines from the cutting tool manufacturer's operating manual.

POWER DRIVEN ABRASIVE WHEEL CUTTER

This provides a fast method of cutting iron pipes.

WHEEL CUTTER

An efficient "non-power" cutter is readily available.

WARNING

Chain or compression type cutters should not be used.

TCP SYSTEM ASSEMBLY METHOD

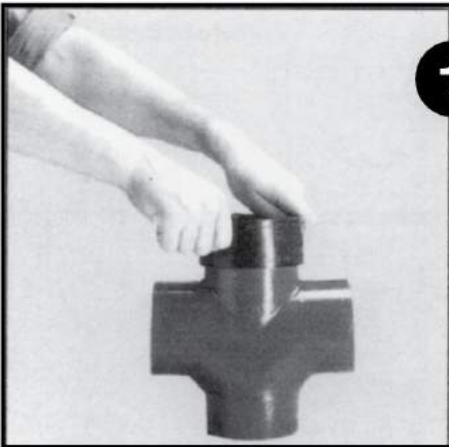

1 Dismantle the TCP coupling and place the gasket over the spigot.

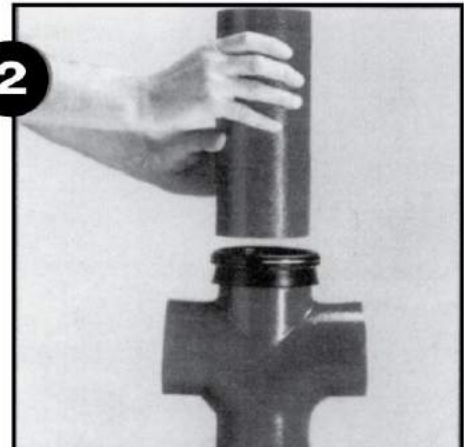

2 Roll back the gasket, offer the next spigot into position ensuring the central register of the gasket is between the spigots.

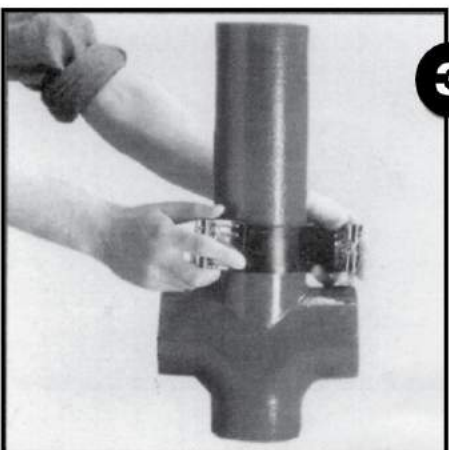

3 Wrap the TCP stainless steel collar around joint ensuring the gasket is within the collar.

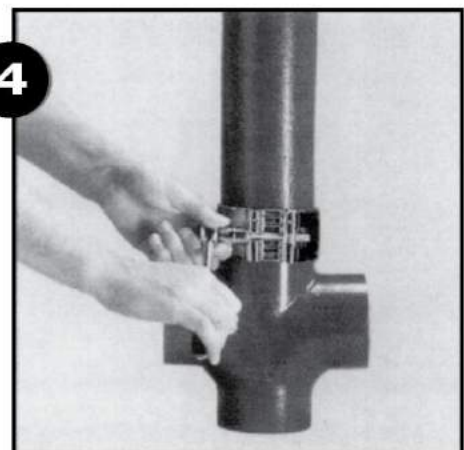

4 Tighten the bolt and the joint is complete.



INSTALLATION

Horizontal suspension

According to plumbing codes, it is usually support horizontal pipe at each joint showing as Figure 1. When the piping system is filled with water, support or hanger shall be located at every 10 feet intervals. Piping system shall maintain alignment and prevent sagging.

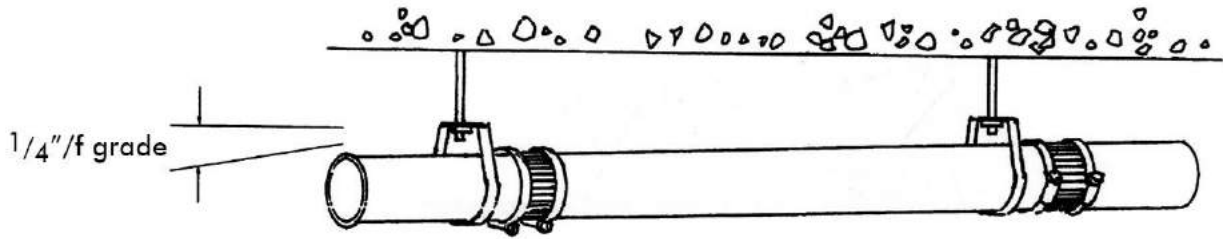
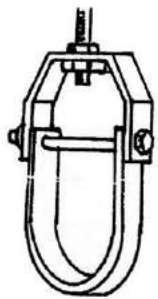

Figure 1

Any of horizontal support illustrated in Figure 2 may be used to hold pipes directly.



Adjustable Clevis Hanger



Type A Bracket

Figure 2

For suspension to T beams, bar joints, junior beams or other structural members, Beam clamps or "C" clamps showing as Figure 3 must be used together with hangers to prevent welding works at site.

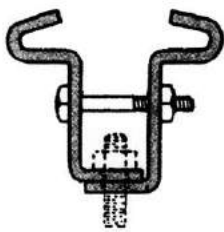

Adjustable Beam Clamp

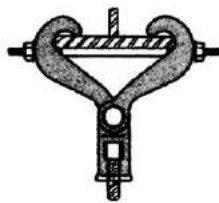

Beam Clamp

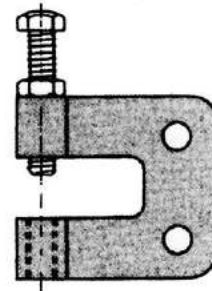

C-Clamp

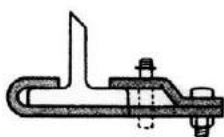

Side Beam Clamp

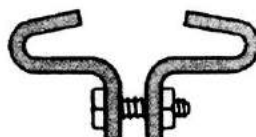

Beam Clamp

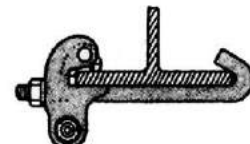

Side Beam Clamp

Figure 3

Whatever method of supports or clamps is used for horizontal line, care shall be taken to make certain that the line has a proven grade (1/4 inch per foot minimum) showing as Figure 1.

INSTALLATION

Horizontal pipes and fittings in six (6) inches and larger shall be suitably braced to prevent horizontal movement. This shall be done at every branch opening or change of direction by the use of brackets, blocks, rods or other suitable method to prevent movement such as figure 4.

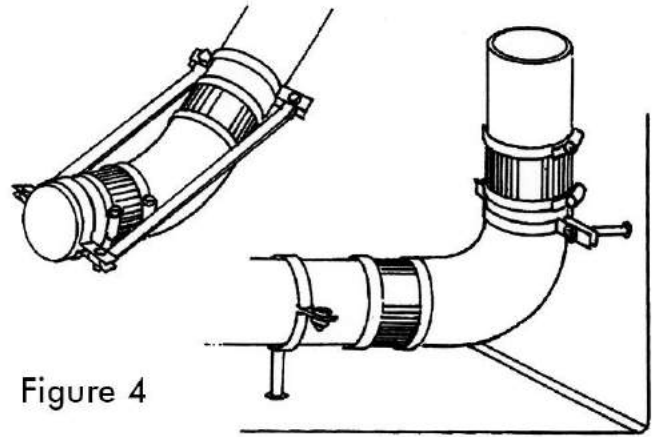
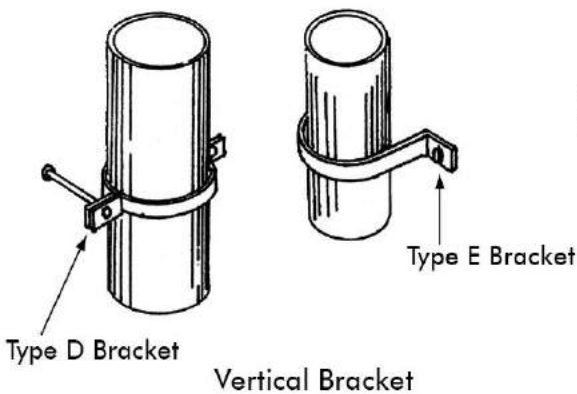

Figure 4

Vertical piping

Vertical components shall be secured at each stack base and at sufficiently close intervals to keep the system in alignment and to adequately support the weight of the pipe and its contents. Figure 5 is showing two types of bracket to support pipe on wall vertical Raiser clamp so called as friction clamps, are required for vertical piping through story slab and structural deck in order for each floor to carry its share of the load showing as Figure 6.



Vertical Bracket

Figure 5

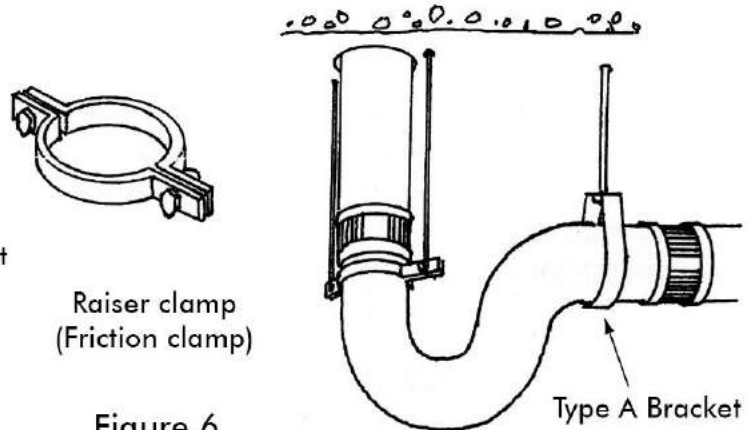

Figure 6

Maintainance

When a hubless blind plug is used for a required cleanout, the complete coupling and plug must be used and accessible for removal or replacement at a accessible corner in building or basement showing as Figure 7. To inspect inside of pipes and to clean deposited fat inside of pipe, CCTV inspection camera can be used to locate the place to be cleaned. Usually, deposited fat can be brushed away by spring tools and washed away by high pressure water-jet.

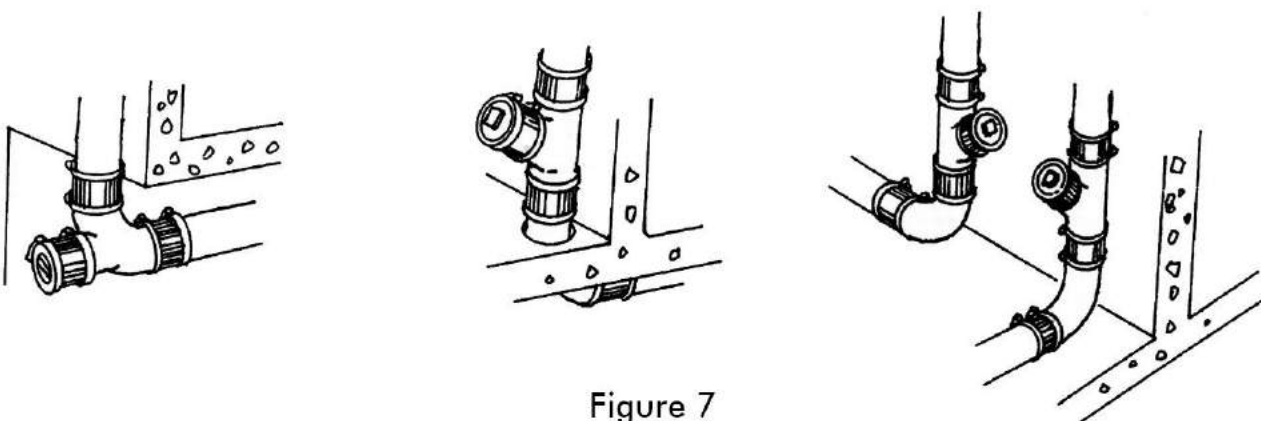
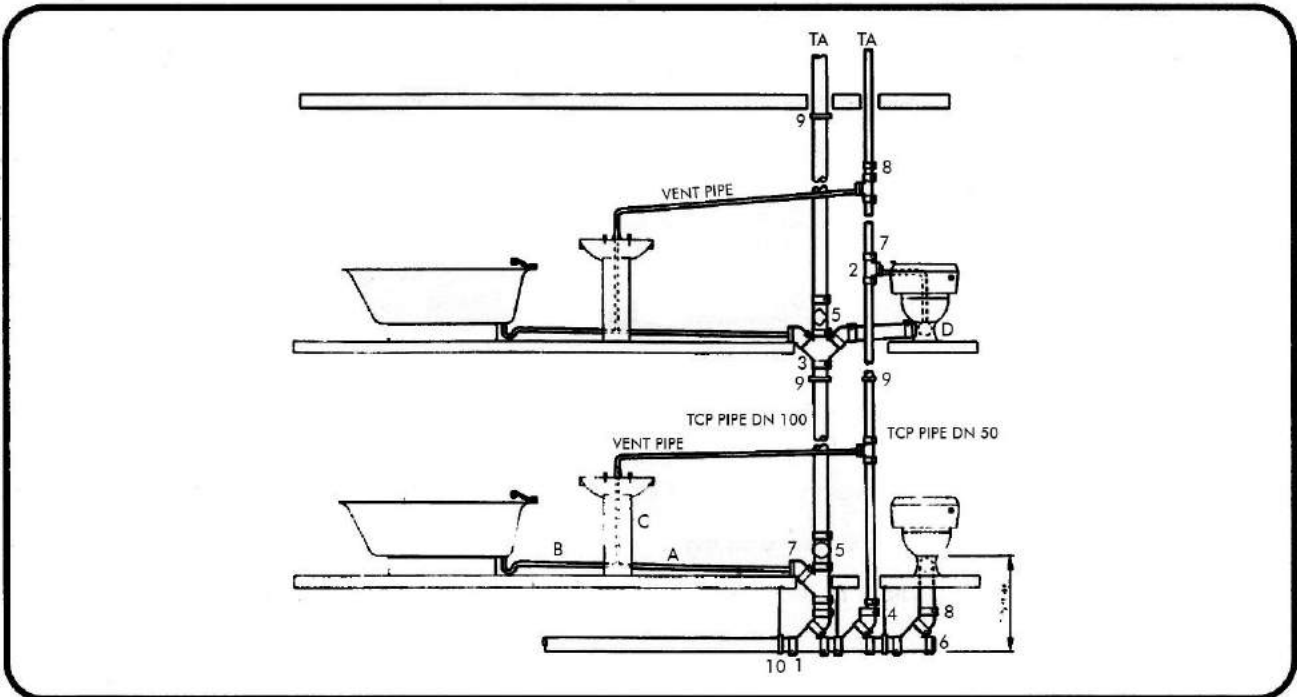

Figure 7

TYPICAL ASSEMBLIES

Single stack with secondary ventilation Typical 4 or 5 storey building



- | | | |
|-------------------------------|---------------------------|------------------------------|
| 1 45° single branch | 6 Plug | A uPVC pipe DN 50 |
| 2 90° single branch | 7 Universal plug | B uPVC pipe DN 40 |
| 3 45° double branches | 8 TCP coupling | C uPVC pipe DN 32 |
| 4 Diminishing piece 100/50 | 9 Vertical pipe strap | D uPVC connection for toilet |
| 5 Short pipe with access door | 10 Horizontal pipe hanger | |

Connection for public sanitary appliances

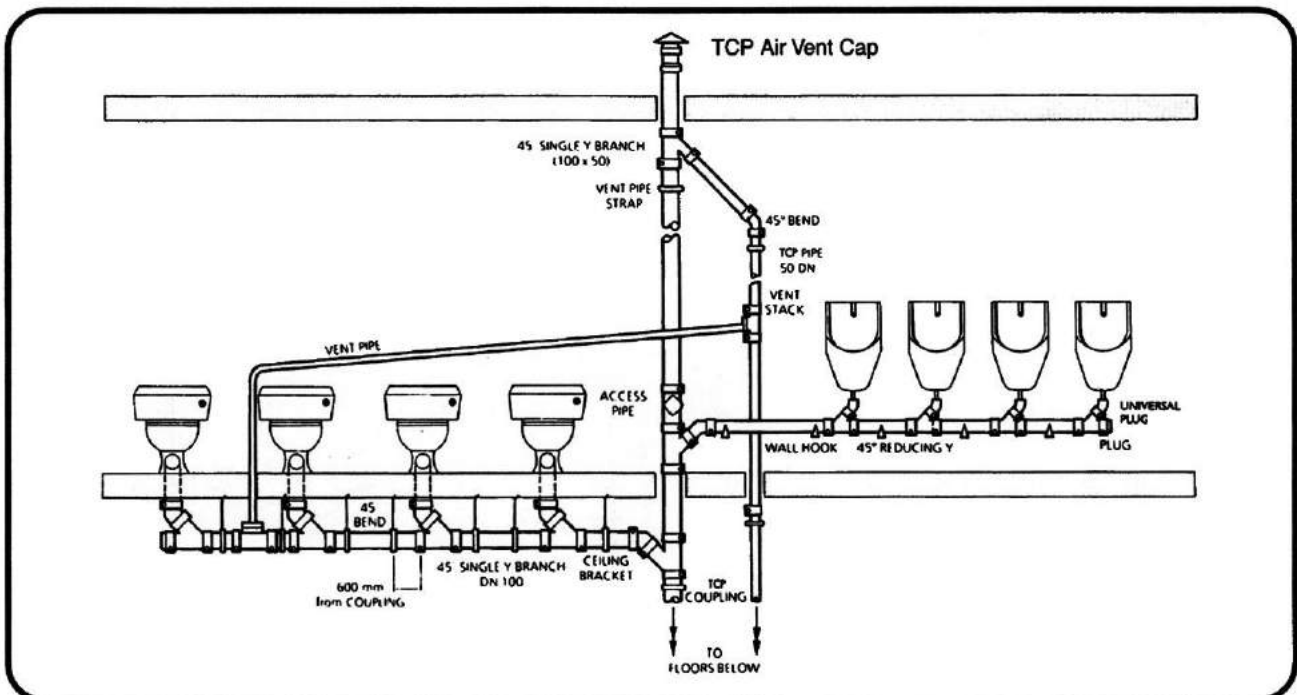

TYPICAL ASSEMBLIES

Double stack with pipework connected to floor drain buried in slab (multi-storey building)

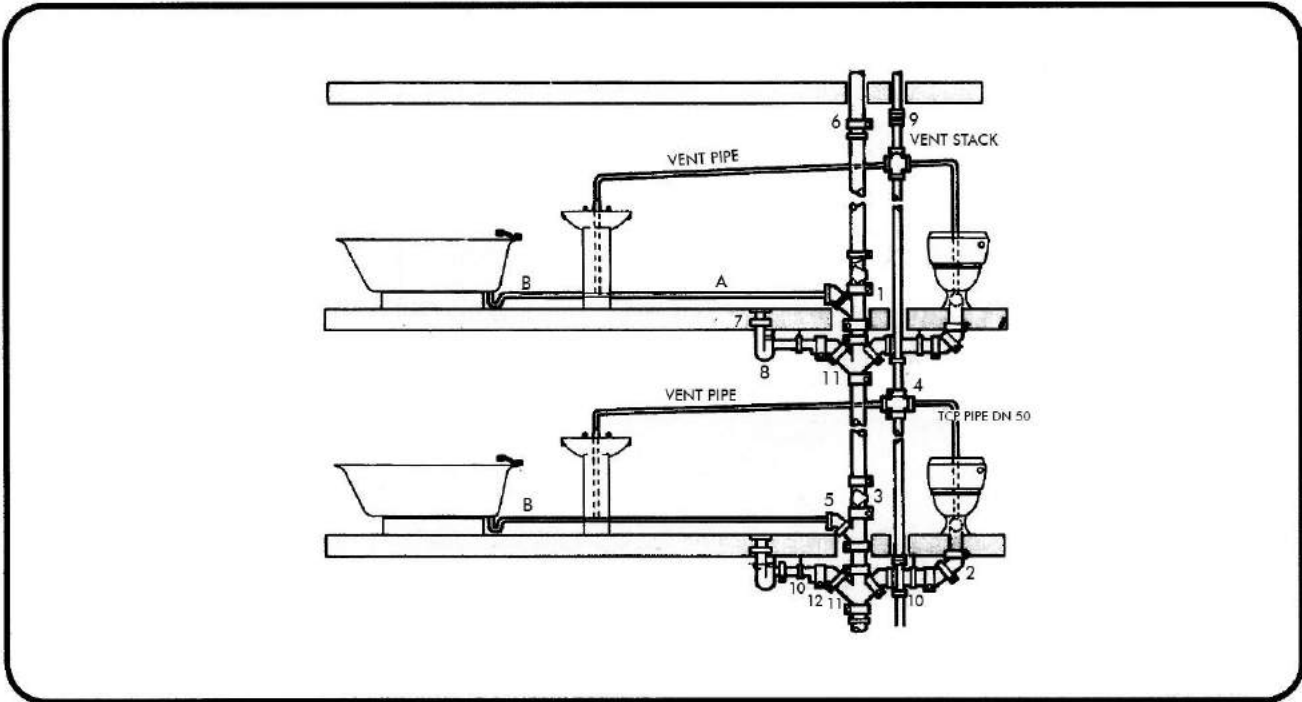

- | | | |
|-------------------------------|---|--|
| 1 45° single branch | *7 TCP Floor drain | A uPVC pipe DN 50 |
| 2 45° bend | *8 P-Trap | B uPVC pipe DN 40 |
| 3 Short pipe with access door | 9 Vent pipe clamp | |
| 4 90° double branch | 10 Horizontal pipe hanger
or wall brackets | |
| 5 Universal plug | 11 DBL 45° branch | *Depending upon design trap may be
incorporated within the floor drain. |
| 6 TCP coupling | 12 Diminishing piece | |

Double stack without secondary ventilation

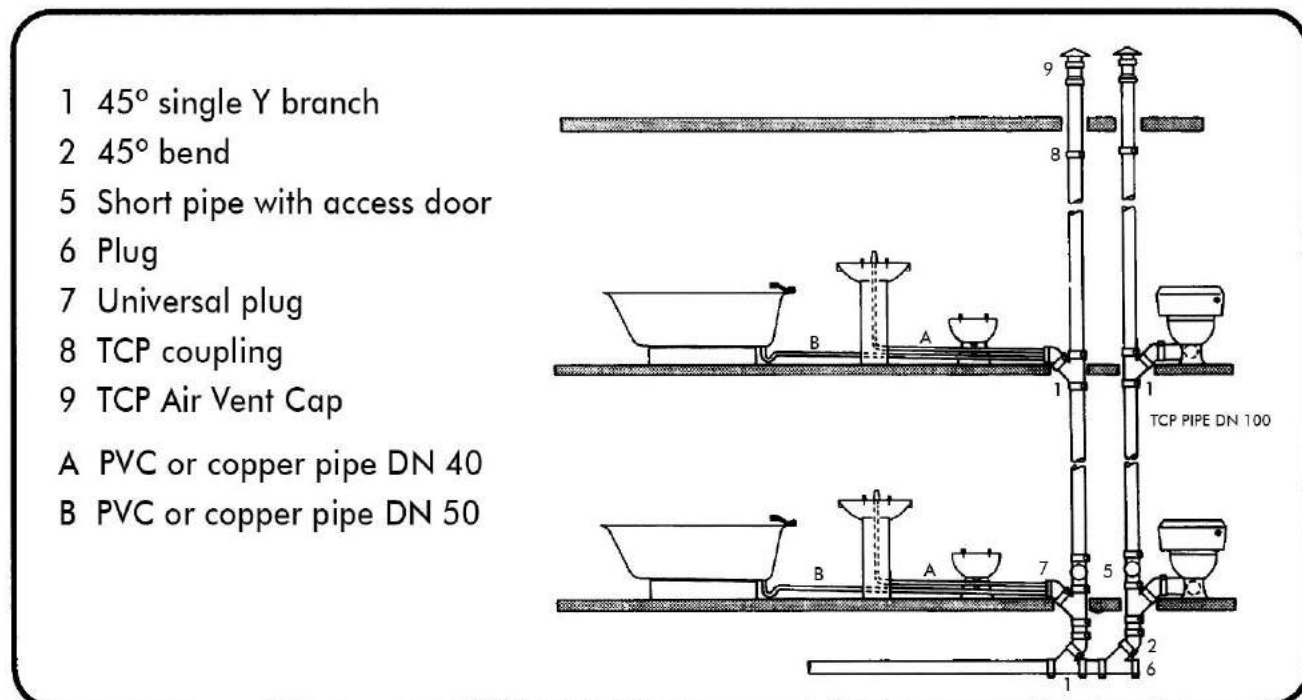

- | |
|-------------------------------|
| 1 45° single Y branch |
| 2 45° bend |
| 5 Short pipe with access door |
| 6 Plug |
| 7 Universal plug |
| 8 TCP coupling |
| 9 TCP Air Vent Cap |
| A PVC or copper pipe DN 40 |
| B PVC or copper pipe DN 50 |