

INSTALLATION INSTRUCTIONS:

1: install the hook first

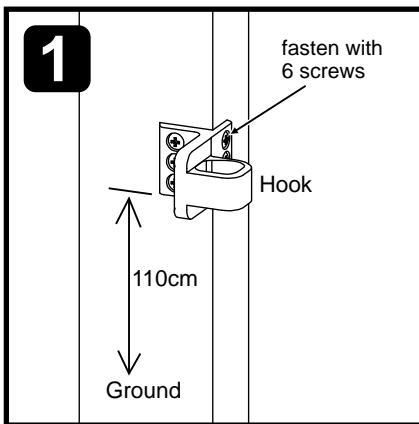

2: make a mark as a position guide for installing the base plate

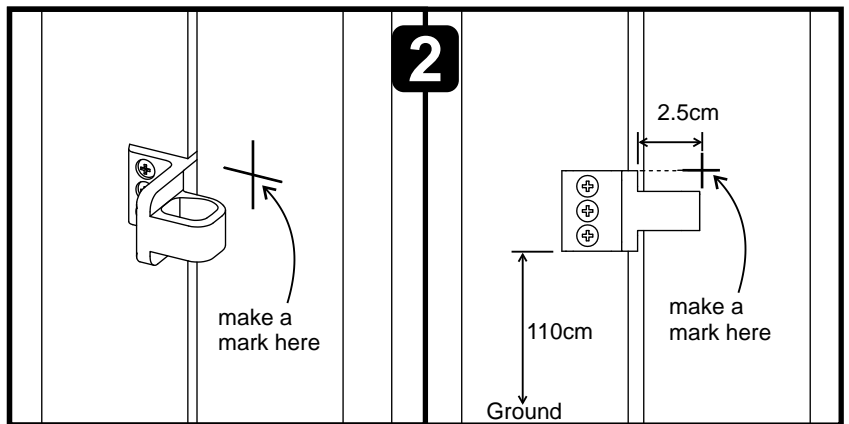

3: align the hole (base plate) to the mark

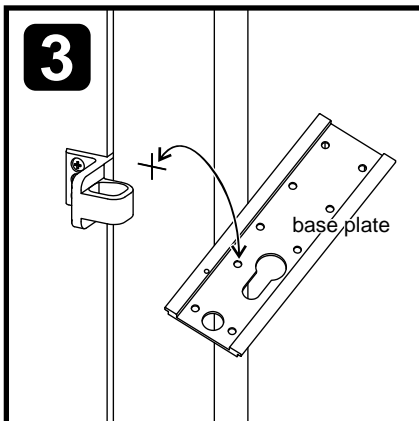

4: install the base plate after aligned to the mark



5: slide in the main unit

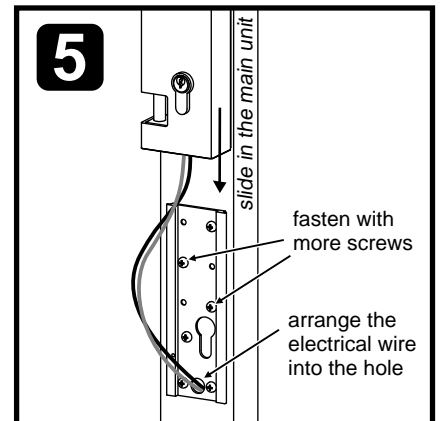

6: fasten the main unit to the base

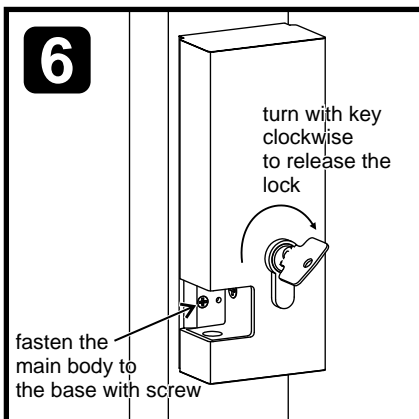

7: add a stack if it is for swing type gate

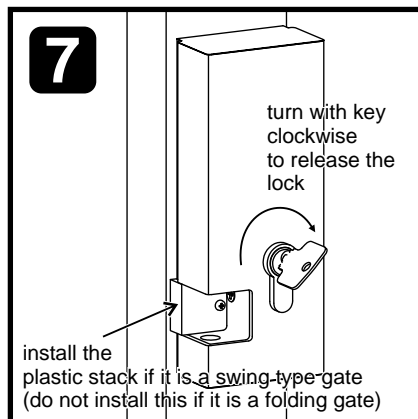

8: installation completed

