

Model : VELR 75/R

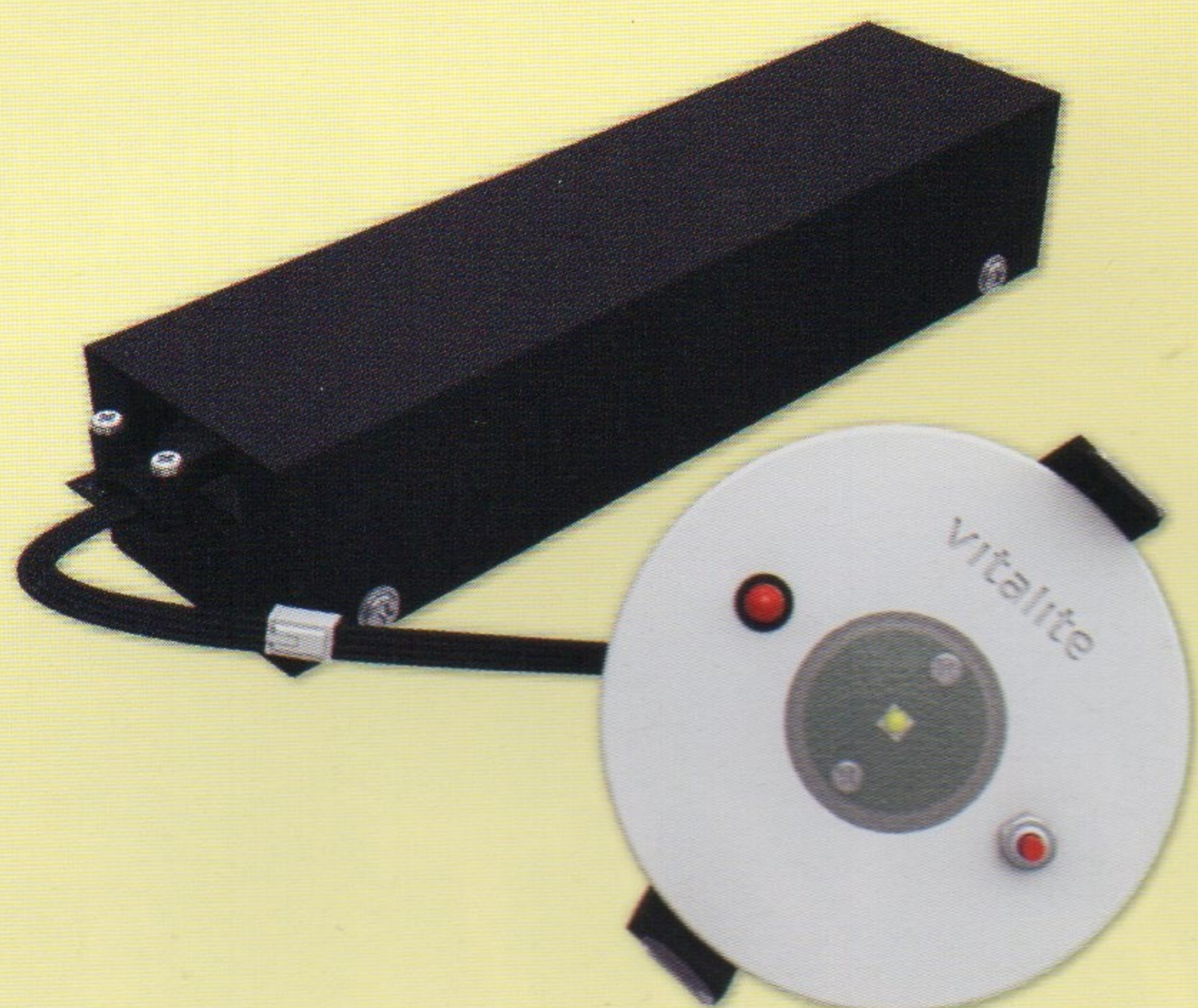

Model : VELR 115/R



Dimension (mm) :

Specifications :

- Die Cast Aluminium Rim (White)
- Separate Mild Steel Gear Box (Black)
- Stainless Steel Spring Clips
- Polycarbonate Opal Diffuser

Test Standard :

- MS 619-2-22:2005
- MS IEC 60598-1:2012

Mounting Method :

- Recessed Plaster Ceiling
- VELR 75 - Hole Cut: D67 mm
- VELR 115 - Hole Cut: D100 mm

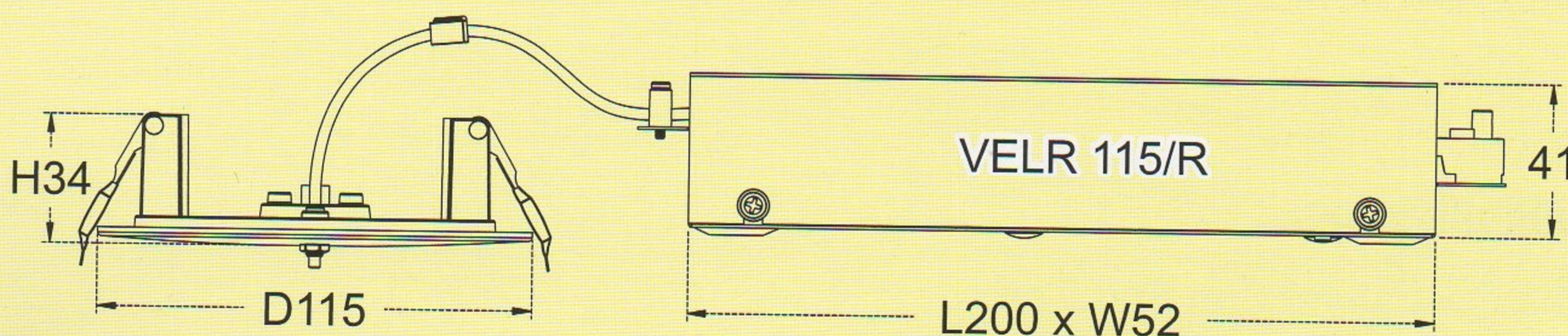
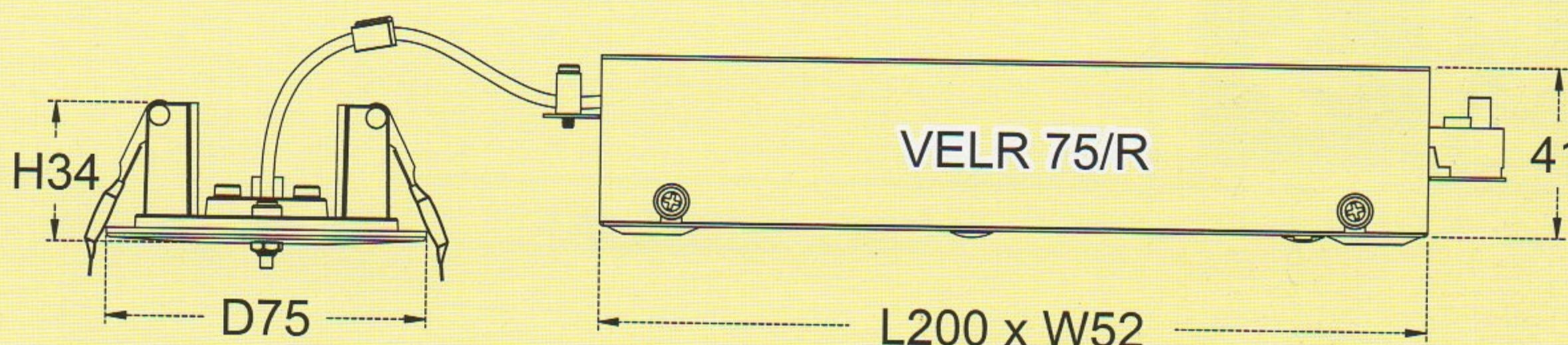

CERTIFIED BY :

SIRIM QAS INTERNATIONAL SDN. BHD.
JABATAN BOMBA DAN PENYELAMAT MALAYSIA

Mains Supply	220 – 240V 50/60Hz	Rating	< 0.05A / < 3.5W / < 0.6 PF	
Mode of Operation	Non-Maintained	Classification	Class 1	
Lamp	LED 1 piece X 5W	Degree of Protection	IP 20	
Battery	Ni-Cd SC 3.6V 1.7Ah	Max. Operating Temperature (Ta)	35°C	
Emergency Duration	Min. 3 Hours	Recommended Mounting Height	Min. 2.3m	
Recharge Period	14 - 16 Hours	Weight	VELR 75/R	0.53 KG
			VELR 115/R	0.57 KG

Packing : 10 sets per Carton box

Carton box (VELR 75/R) : 375 X 95 X 85 mm (0.92 kg) Rim Only

Carton box (VELR 115/R) : 375 X 130 X 1255 mm (1.30 kg) Rim Only

Control Gear carton box : 425 X 255 X 95 mm (4.8Kg)