

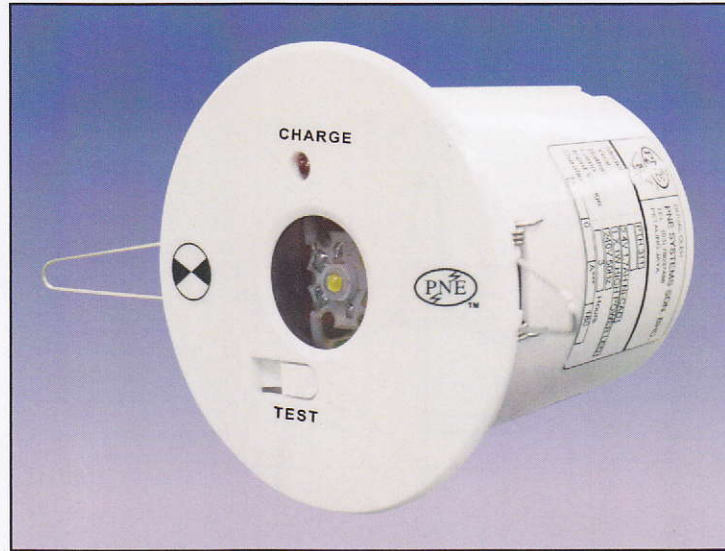

Self-Contained Emergency Luminaire

1x 1.0 W Power LED

PTH-311



Specifications

- Model** ➔ PTH-311
- Mode** ➔ Non-maintained
- Weight** ➔ 320 grams
- Battery** ➔ High temperature rated sealed nickel-cadmium
- Housing** ➔ PC + ABS + UV plastic fire retardent
- Charger** ➔ Constant Current
- Mounting** ➔ Ceiling recessed mounted
- Dimension** ➔ 75 mm (L) x 88 mm (W) x 95 mm (Diameter)
- Monitoring** ➔ Red LED - indicating charging
Equipped with momentary switch to simulate power failure
- Compliance** ➔ SIRIM MS 619 : Part 102 ; Sect. 102.22
MS IEC 60598-1 : 2003
- Light Source** ➔ 1W high power LED
- Input Voltage** ➔ 240V / 50Hz
- Recharge Period** ➔ 16 - 24 Hours
- Back Up Duration** ➔ 3 Hours
- Battery Protection** ➔ Low voltage cut-off to prevent over discharging
- Degree of Protection** ➔ IP - 20

For further enquiries, please contact :-
PNE SYSTEMS SDN. BHD. (263861 D)
 No.3, Jalan SS26/13,
 Taman Mayang Jaya 47301, Petaling Jaya,
 Selangor Darul Ehsan, Malaysia
 Tel : 603-78037488 (Hunting)
 Fax : 603-78038509
 E-mail : sales@pnesys.com.my
 Website : www.pnesys.com.my

Note : Due to continuous development and improvement, our company reserves the right to change specifications without notice.



MODEL PTH-311

Self-Contained Emergency Luminaire

1x 1.0W Power LED

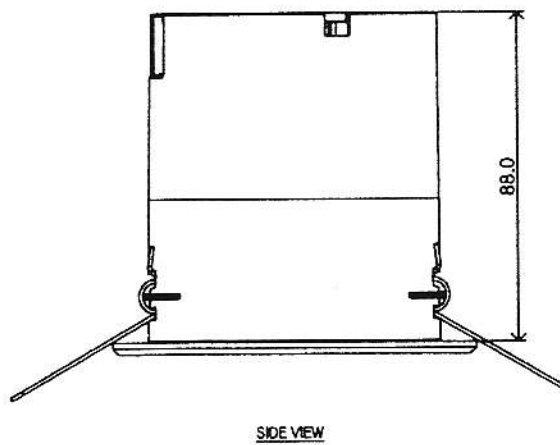
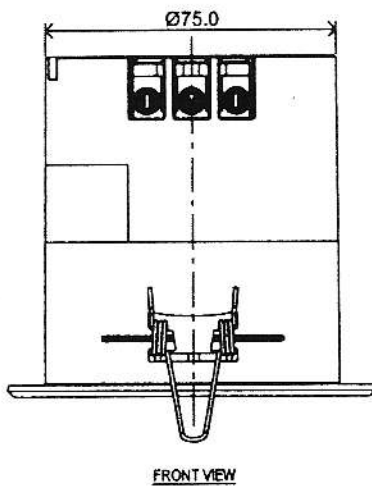
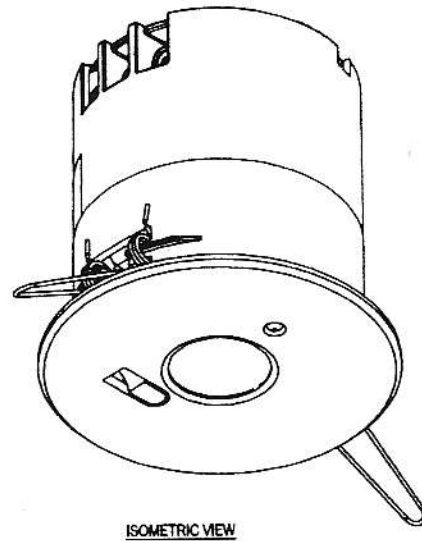
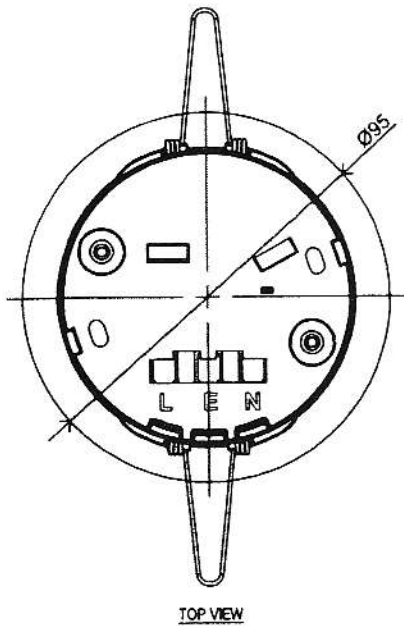

For further enquiries, please contact :
PNE SYSTEMS SDN. BHD. (263861 D)
No. 3, Jalan SS 26/13,
Taman Mayang Jaya, 47301 Petaling Jaya,
Selangor Darul Ehsan, Malaysia.
Tel : 03-7803 7488 (Hunting)
Fax: 03-7803 8509
E-mail: sales@pnesys.com.my



Note : Due to continuous development and improvement, our company reserves the right to change specification without notice.