

AL 01000 series highbay



order code

casing model	lamp wattage	lamp type	weight (kg)	order code
AL 01000 highbay	MH 700W	bulb	12.5	AL 01000 - M0700
AL 01000 highbay	MH 1000W	bulb	14.0	AL 01000 - M1000
AL 01000 highbay	HPMV 700W	bulb	12.0	AL 01000 - H0700
AL 01000 highbay	HPMV 1000W	bulb	13.5	AL 01000 - H1000
reflector model			weight (kg)	order code
AL reflector	RAL22MFWR		1.5	RAL22MFWR
attachment	dimension (mm)	thickness (mm)	weight (kg)	order code
Tempered glass visor	ø570	5	3.2	VGAL22MFW

note : specifications are subject to change without prior notice

dimension

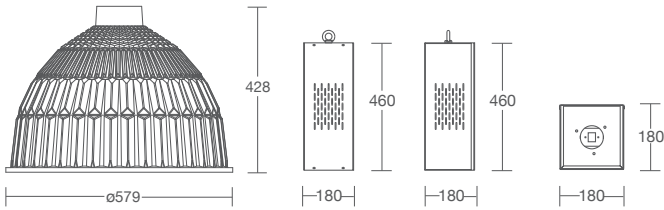

RAL 22MFWR 22" AL reflector

AL 01000 casing

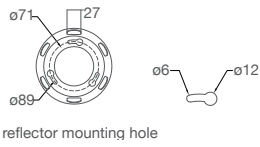

reflector mounting hole

photometric curve

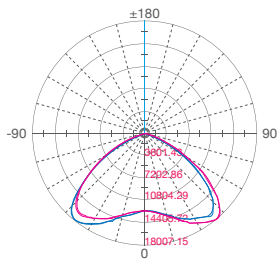

note : photometric result tested based on 87000lm MH 1000W coated bulb c/w RAL22MFWR 22" Aluminium Reflector

key for standard order coding

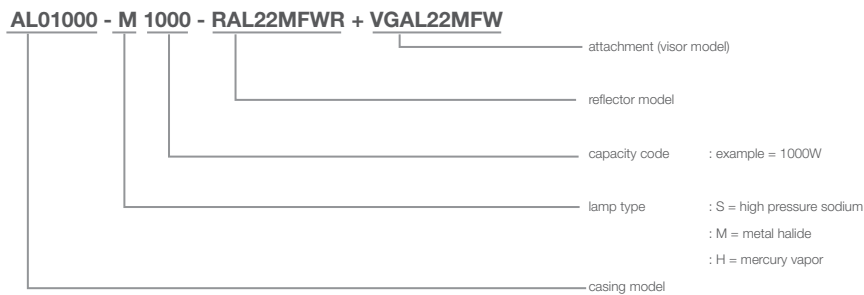

features

- control gear housing**
 - high quality cold rolled steel complete with epoxy powder coating
- reflector**
 - high purity anodized polished aluminium reflector
- tempered glass**
 - optional visor can be mounted onto the reflector for safety purposes
- others**
 - ceramic lamp holder and thermal resistant fiber glass wire

installation diagram

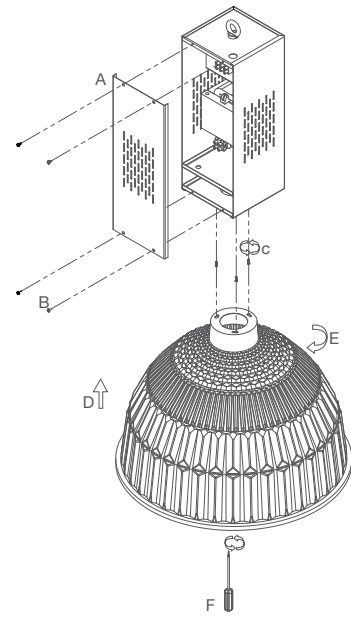

- A. close the front cover
- B. tighten the cover screw
- C. tighten the mounting screw to allow spacing to fix the reflector
- D & E : fix and turn the reflector to the highbay casing
- F: tighten the screw to secure the reflector

technical data

- voltage • 220 - 240 Vac 50 Hz / 60Hz
- lamp wattage • 700W - 1000W
- holder type • E40 ceramic lamp holder
- colour of housing • light grey