

Program: DMS-4W 4-Step Rotation

Operation: This program is used to control the rotation of 4 water pumps.

Supply: L-N (240VAC)

Inputs: CS-S0-S1-S2-S3-S4-M/A (Use only volt-free contacts)

CS-S0 Stop Level

CS-S1 Level 1 - 1st Pump

CS-S2 Level 2 - 2nd Pump

CS-S3 Level 3 - 3rd Pump

CS-S4 Level 4 - 4th Pump

Outputs: CT-T1-T2-T3-T4 (Volt-free contacts rating: 5A 240VAC)

CS-T1 Pump 1

CS-T2 Pump 2

CS-T3 Pump 3

CS-T4 Pump 4

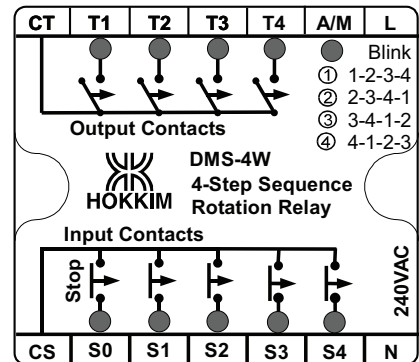

- (1) Only volt-free contacts should be used to signal inputs.
- (2) On power on, with all inputs opened, all outputs will stay opened.
- (3) When CS-S0 closes, latching of the volt-free output contacts CT-T1, CT-T2, CT-T3 and CT-T4 are enabled.
- (4) The closing of any one of the input terminals CS-S1, CS-S2, CS-S3 or CS-S4 will cause one of the output contacts CT-T1, CT-T2, CT-T3 or CT-T4 to close. CS-S1 will energized the 1st output which may be CT-T1, CT-T2, CT-T3, or CT-T4 depending on the sequence in effect. Every time CS-S0 re-opens after closing, the sequence changes from T1-T2-T3-T4 to T2-T3-T4-T1 to T3-T4-T1-T2 to T4-T1-T2-T3 and back to T1-T2-T3-T4 and so on.

Sequence	1st Output	2nd Output	3rd Output	4th Output
1	T1	T2	T3	T4
2	T2	T3	T4	T1
3	T3	T4	T1	T2
4	T4	T1	T2	T3

- (5) The Blink LED at the top right corner will indicate the sequence in effect as follows:
 - Sequence 1 On-Off Pause On-Off Pause On-Off Pause.....
 - Sequence 2 On-Off-On-Off Pause On-Off-On-Off Pause On-Off-On-Off Pause.....
 - Sequence 3 On-Off-On-Off-On-Off Pause On-Off-On-Off-On-Off Pause On-Off-On-Off-On-Off.....
 - Sequence 4 On-Off-On-Off-On-Off On-Off Pause On-Off-On-Off-On-Off On-Off.....
- (6) The input signal must be present continuously for 1 sec. before the output contacts will close. This is to prevent false trigger. Also, if for any reason all four input signals are present simultaneously, there will be 10 sec. intervals between the closing of the output contacts. The delay intervals are to prevent excessively high transient currents.
- (7) The output contacts will remain close until CS-S0 re-opens. CS-S0 must remain open continuously for 5 sec before the first output releases. This is to avoid false trigger owing to water ripples. Thereafter, the second, third and fourth outputs are released after 5 sec. intervals. The delay intervals are again to prevent excessively high transient currents.
- (8) When CS-A/M is shorted, the sequence will be held; that is, there will be no sequence change with the release off Stop Level CS-S0.
- (9) When CS-S0 is opened and all outputs are off, opening CS-A/M after closing it will cause the sequence to change, Thus, you can use CS-A/M to select a particular sequence and hold it at the sequence if you so desire.
- (7) Upon power failure, the sequence will reset to T1-T2-T3-T4. The DMS-4W is based on a micro controller whose embedded program will always reset upon power up. If you have to maintain the sequence upon mains failure, battery backup power must be used to maintain supply to the DMS-4W.

