

# HÄFELE TENCON



www.hafele.com.my

## KOSMO KITCHEN STORAGE.

Edition 01/2022

# HÄFELE - WHERE TRUST WAS BUILT FROM COMPETENCE



Founded in Germany in 1923, Häfele is a world-renowned provider of smart home and project solutions. Häfele's superior range of products not only exemplifies German quality standards, but is developed with the philosophy of "functionality" and "easiness" in mind to offer reliable solutions for both professionals and consumers.

Since the establishment in Malaysia in 1993, Häfele has been continuously improving and expanding its products and services, making the key components of Malaysian homes - door security as well as kitchen, wardrobe and the home appliances to a much more efficient spaces.

With innovative solutions, adherence to high standards and a dedicated team, Häfele Malaysia looks to create more modern and optimal living spaces for Malaysian in the future.

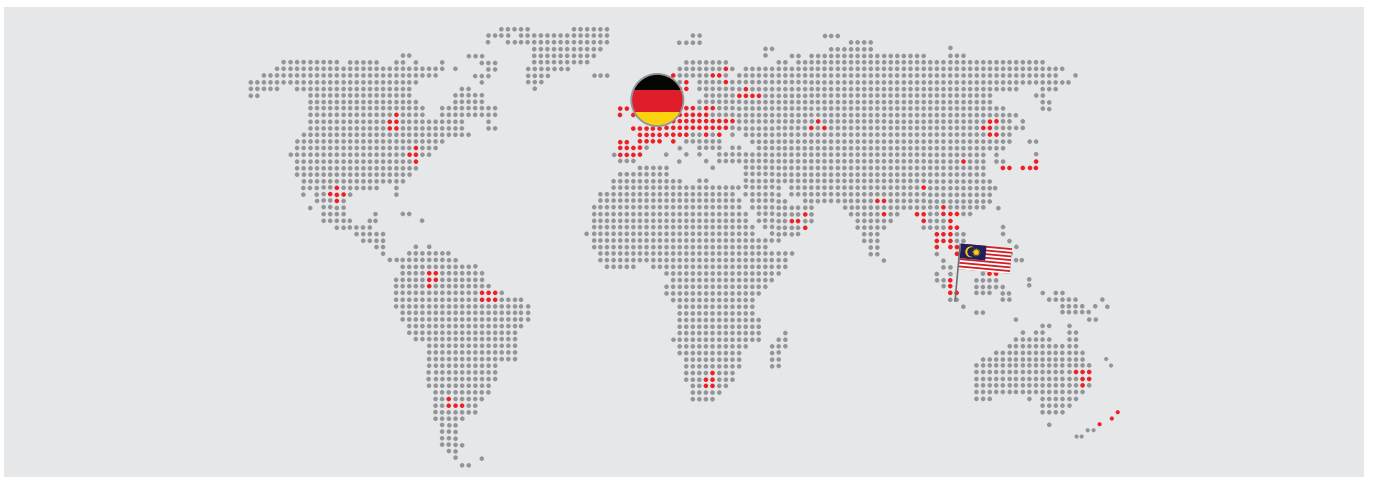

# OUR ADVANTAGES ARE YOUR BENEFITS.

With almost a century of experience and expertise knowledge, Häfele has been trusted by many famous architects, designers, contractors, and developers around the world, when it comes to smart home and project solutions. In Malaysia, Häfele has too established our name as a reliable solution provider among professionals across the sectors of architecture, furniture, and real estate.



## GERMAN QUALITY

Häfele's solutions are developed with German technologies and quality standards to be of the highest functionality, offering you easiness that will translate into efficiency.

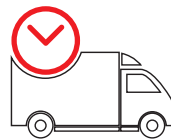

## AVAILABLE FROM STOCK

As Häfele boasts large distribution centers around Malaysia, almost everything you need is ready for order.



## FAST DELIVERY

Door-to-door service. With speed.

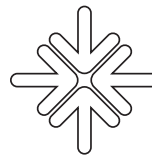

## TAILOR-MADE SOLUTIONS

Häfele's solutions come with huge customizability to be perfectly suited for every different need.

# NEAT KITCHEN, HAPPY COOKING.



Warranty 5 years.



European-styled design catered to Asian cooking habits: The fittings can be integrated smoothly into cabinets, optimizing every corner and every door.



High resistance to rust to guarantee highest quality, while increasing the surface's hardness, maintaining the good look of finishes for a long time. Runners have also passed 60,000 cycles of testing to serve your kitchen long and well. Quality finishes with anti-slip grey mats makes an impressive touch when pulled out.

# KOSMO

Pull-outs with adjustable sizes for your storing demands are a perfect solution for base cabinets, corner cabinets, wall cabinets and tall cabinets. With just a slight pull, everything you need for cooking and setting up table for a family meal will come right into your hands.





## OMERO 150

- > Designed for narrow spaces
- > Adjustable trays for all kinds of spice jars
- > Clip-on soft-closing runners with side-mounted baskets
- > Anti-slip mat for preventing tumbles when opened / closed
- > Left or right installation
- > Maximum weight capacity: 35 kg

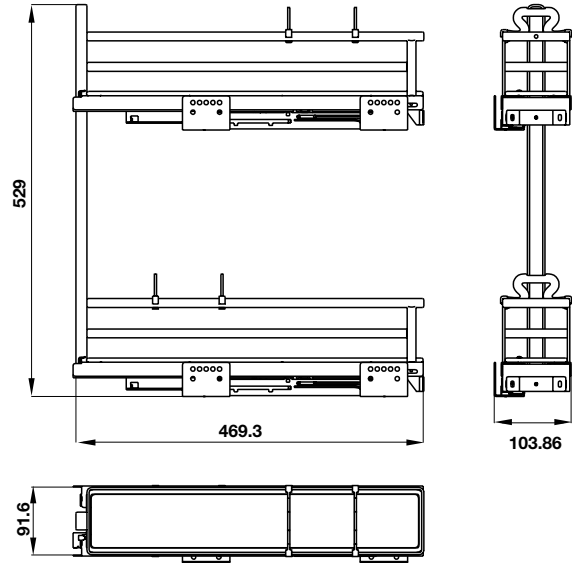

### OMERO 150

Finish	Cabinet width (mm)	Internal cabinet depth (mm)	Dimension (WxDxH) (mm)	Art. No	Quantity		
					1+	6+	21+
Anthracite	150	490	105 x 482 x 510	549.20.340	559.00	542.00	514.00
	200	490	155 x 482 x 510	549.20.341	619.00	600.00	569.00

Set components complete with base unit front extension set, 6 pieces dividers, trays with anti-slip mat and fixing material  
 Packing: 1 set



## OMERO 300

- > Adjustable trays for all kinds of spice jars
- > Clip-on soft-closing runners
- > Anti-slip mat for preventing tumbles when opened / closed
- > Maximum weight capacity: 35kg

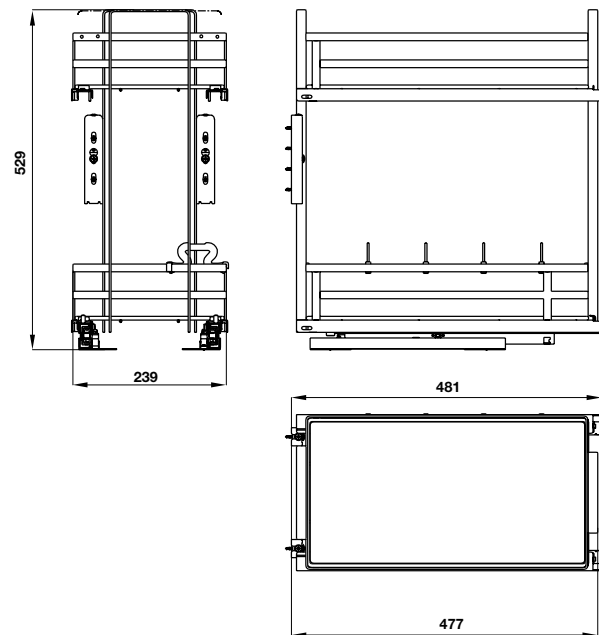

### OMERO 300

Finish	Cabinet width (mm)	Internal cabinet depth (mm)	Dimension (WxDxH) (mm)	Art. No	Quantity		
					1+	6+	21+
Anthracite	300	490	243 x 483 x 530	549.20.323	659.00	639.00	606.00

Set components complete with 2 full extensions runner with soft close mechanism, pull out frame, 2 front brackets, 1 divider bar, 4pcs dividers, trays with anti-slip mat and fixing material  
 Packing: 1 set



## OMERO MULTI-S

- > Adjustable trays for all kinds of spice jars, utensils, cutlery, and bottles
- > Clip-on soft closing runners with multi-dividers
- > Anti-slip mat for preventing tumbles when opened / closed
- > Maximum weight capacity: 35 kg

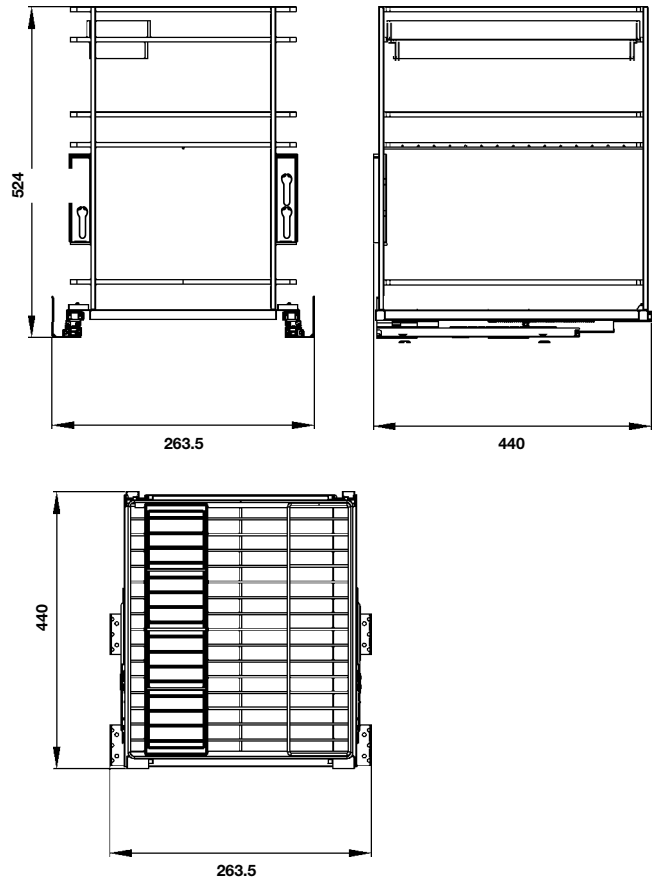

### OMERO MULTI-S

Finish	Cabinet width (mm)	Internal cabinet depth (mm)	Dimension (WxDxH) (mm)	Art. No	Quantity		
					1+	6+	21+
Anthracite	300	490	250 x 460 x 523	595.00.423	599.00	581.00	551.00

Set components complete with pull out frame, full extension with integrated soft closing mechanism, 2 front brackets, plastic holder, tall bottle divider, tray with anti-slip mat and fixing material  
 Packing: 1 set





## KASON FLEX

- > Diverse tray designs for tableware and cutlery
- > Trays are easily removed for cleaning and setting up table
- > Anti-slip mat for preventing tumbles when opened / closed
- > Maximum weight capacity: 35 kg

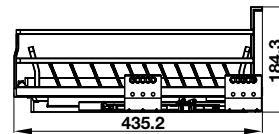
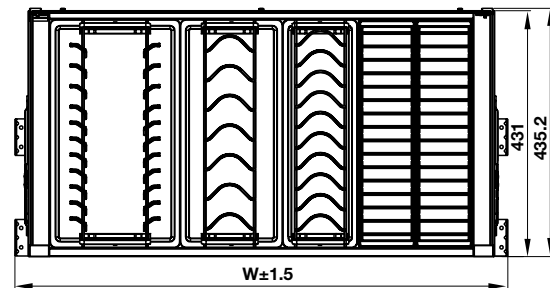
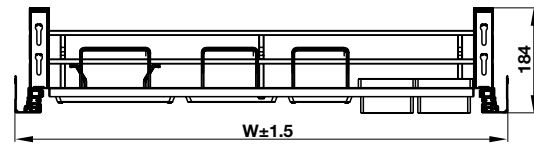

	W
600	563.5
900	863.5

### KASON FLEX

Finish	Cabinet width (mm)	Internal cabinet depth (mm)	Dimension (WxDxH) (mm)	Art. No	Quantity		
					1+	6+	21+
Anthracite	600	450	564 x 435 x 184	549.08.384	549.00	533.00	505.00
	900	450	864 x 435 x 184	549.08.388	679.00	659.00	625.00

Set components complete with pull out tray, full extension with integrated soft closing mechanism, 2 front brackets, 1 plastic dish rack, 2 plastic holders, 3 drainer trays and fixing material  
Packing: 1 set

BASE CABINETS



# KASON

- > Anti-slip mat for preventing tumbles when opened / closed
- > Maximum weight capacity: 35 kg

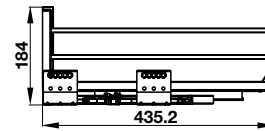
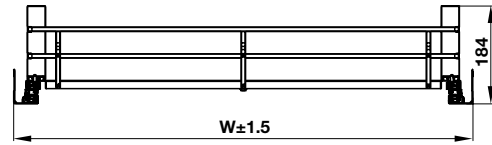

	W
600	563.5
900	863.5

KASON							
Finish	Cabinet width (mm)	Internal cabinet depth (mm)	Dimension (WxDxH) (mm)	Art. No	Quantity		
					1+	6+	21+
Anthracite	600	450	564 x 435 x 184	549.08.364	449.00	436.00	413.00
	900	450	864 x 435 x 184	549.08.368	509.00	494.00	468.00

Set components complete with pull out tray with anti slip mat, full extension with integrated soft closing mechanism, 2 front brackets and fixing material  
 Packing: 1 set



## OLLA MOVE

- > Designed for L-shaped kitchen
- > Trays are swung fully out of cabinet corner and independently, making it easy to arrange and get things
- > Anti-slip mat for preventing tumbles when opened / closed
- > Total maximum weight capacity: 20 kg (10 kg per tray)

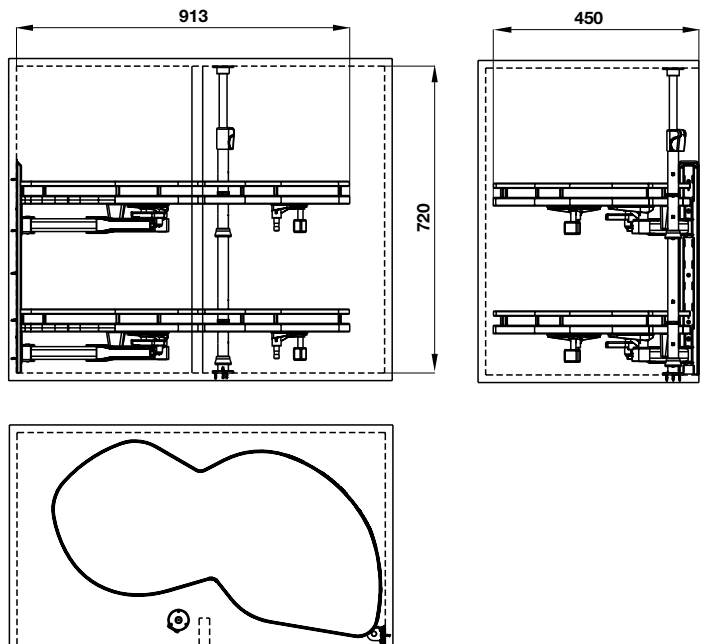

OLLA MOVE								
Finish	Cabinet width (mm)	Internal cabinet depth (mm)	Dimension (WxDxH) (mm)	Version	Art. No	Quantity		
						1+	3+	6+
Anthracite	900	510	915 x 485 x (700 770)	Right side	541.01.405	1,749.00	1,697.00	1,609.00
				Left side	541.01.415	1,749.00	1,697.00	1,609.00

Set components complete with shelves with pre-mounted fitting, spindle, drilling template, including self-closing damping system and fixing material  
Packing: 1 set



## ORIA

- > Easy to lift and pull down for arranging and taking things
- > Anti-slip mat for preventing tumbles when opened / closed
- > 4 weight loading adjustment levels
- > With soft-closing mechanism
- > Total maximum weight capacity: 10 kg

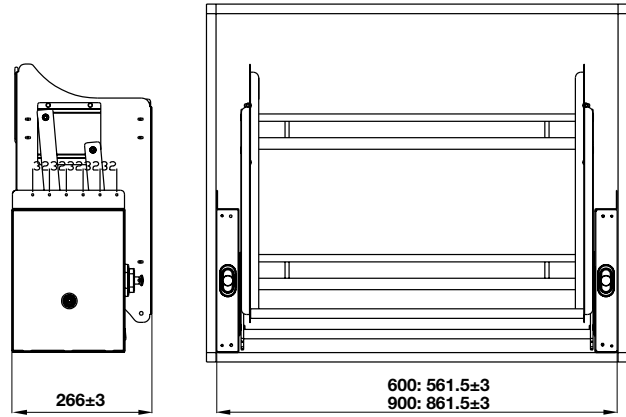

ORIA							
Finish	Cabinet width (mm)	Internal cabinet depth (mm)	Dimension (WxDxH) (mm)	Art. No	Quantity		
					1+	3+	6+
Anthracite	600	280	560 x 280 x 560	504.76.314	1,519.00	1,473.00	1,397.00
	900	280	860 x 280 x 560	504.76.318	1,609.00	1,561.00	1,480.00

Set components complete with fixing material  
 Packing: 1 set



## KARA SWING

- > Door-installed trays optimizing space
- > Clearly divided trays help increase space, making it easy to arrange and take things
- > Anti-slip mat for preventing tumbles when opened / closed
- > Maximum weight capacity: 8 kg/large tray and 3 kg/small tray

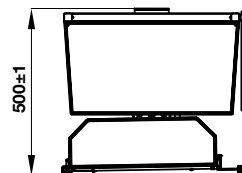
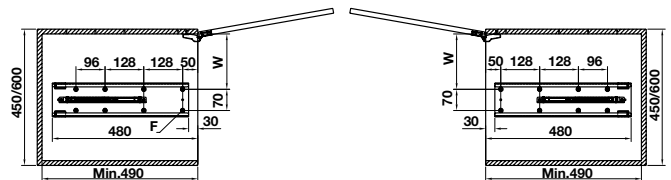
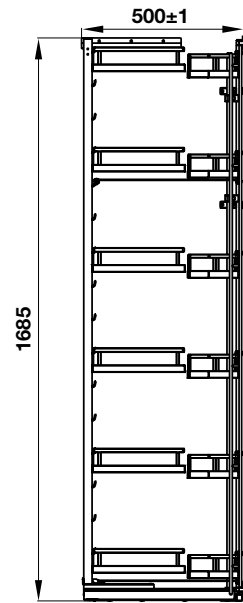
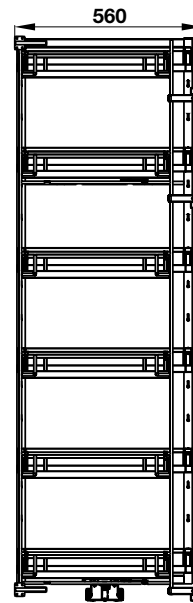

KARA SWING							
Finish	Cabinet width (mm)	Internal cabinet depth (mm)	Dimension (WxDxH) (mm)	Art. No	Quantity		
					1+	3+	6+
Anthracite	450	490	410 x 490 x 1690	548.65.442	2,339.00	2,269.00	2,152.00
	600	490	560 x 490 x 1690	548.65.462	2,719.00	2,637.00	2,501.00

Set components complete with runner with soft close mechanism, pull-out frame, door frame, front brackets, trays/ baskets with anti slip mat and fixing material

Packing: 1 set



HOME  
APPLIANCES



ARCHITECTURAL  
HARDWARE



SMART HOME

**Häfele Malaysia Sdn. Bhd.**

**KL Head Office**

No. 18, Jalan Juruhebah U1/50 Seksyen U1, Temasya Industrial Park, 40150 Shah Alam, Selangor, Malaysia  
Phone: +603 5569 2526 | Fax: +603 5569 3526 | Email: info@hafele.com.my

**PENANG HAFELE TRADE PARTNER**

**TENCON HARDWARE TRADING**

7465, Jalan Tanjung Indah, Pusat Perniagaan Seri Tanjung. 13400 Butterworth. Penang, Malaysia  
Phone: +604 240 9925 Fax: +604 240 9926 Email: Info@tenconhardware.com

**hafele.com.my**  
**tenconhardware.com**



Scan for  
Installation guide