

**68400**
**HFM90°**
**90° Square Shoulder Facing End Mills**

90° Unit:mm

Order No.	Model	D	D1	d	L	L1	A	Flutes	Inserts	Wrench	Screw
68400-01	HFM90-50-25.4-5T	50	48	25.4	40	6.3	10.4	5	AP□□1604	T15	M4-10-5.7-60
68400-02	HFM90-63-25.4-5T	63	48	25.4	40	6.3	10.4	5			
68400-03	HFM90-80-31.75-6T	80	60	31.75	50	7	12.4	6			
68400-04	HFM90-100-31.75-7T	100	78	31.75	50	8	14.4	7			
68400-05	HFM90-125-38.1-8T	125	89	38.1	63	9	16.4	8			
68400-06	HFM90-50-22-5T	50	48	22	40	6.3	10.4	5			
68400-07	HFM90-63-22-5T	63	48	22	40	6.3	10.4	5			
68400-08	HFM90-80-27-6T	80	60	27	50	7	12.4	6			
68400-09	HFM90-100-32-7T	100	78	32	50	8	14.4	7			
68400-10	HFM90-125-40-8T	125	89	40	63	9	16.4	8			

Coolant through design to reduce cutting wear.

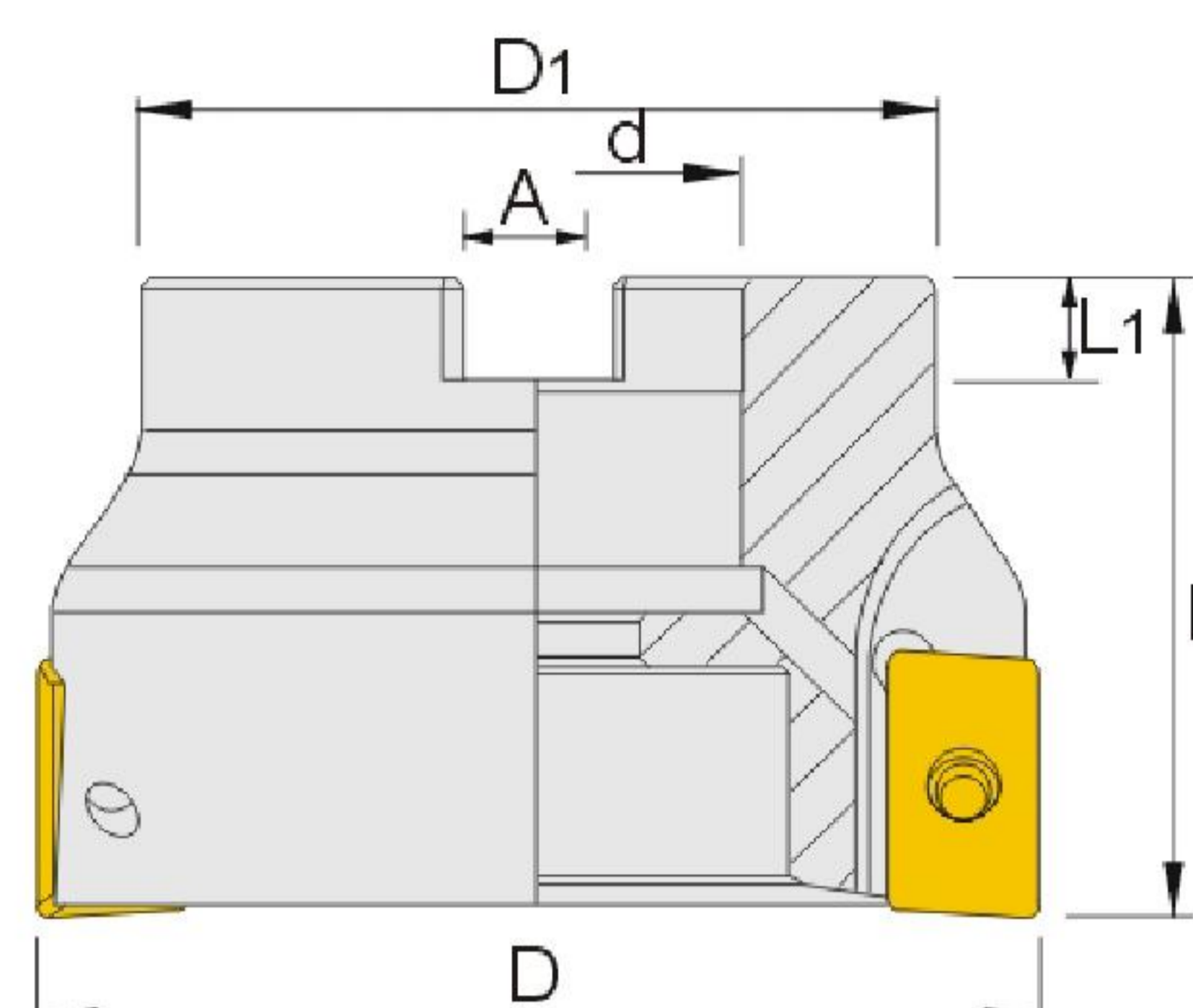

CUTTING TOOL