

# Milling Machine Accessories

**65000**

LK

Tool Machine Vise

PAT: 170861  
ZL 99 2 48851.6



## Features:

- ▶ Adopting new structure and high rigidity design.
- ▶ Powerful clamping force.
- ▶ Suitable for CNC machines, even for parallel use.
- ▶ Material: Tool Steel
- ▶ Hardness: HRC55°-60°
- ▶ Accuracy: 0.003mm/100mm

## Applications:

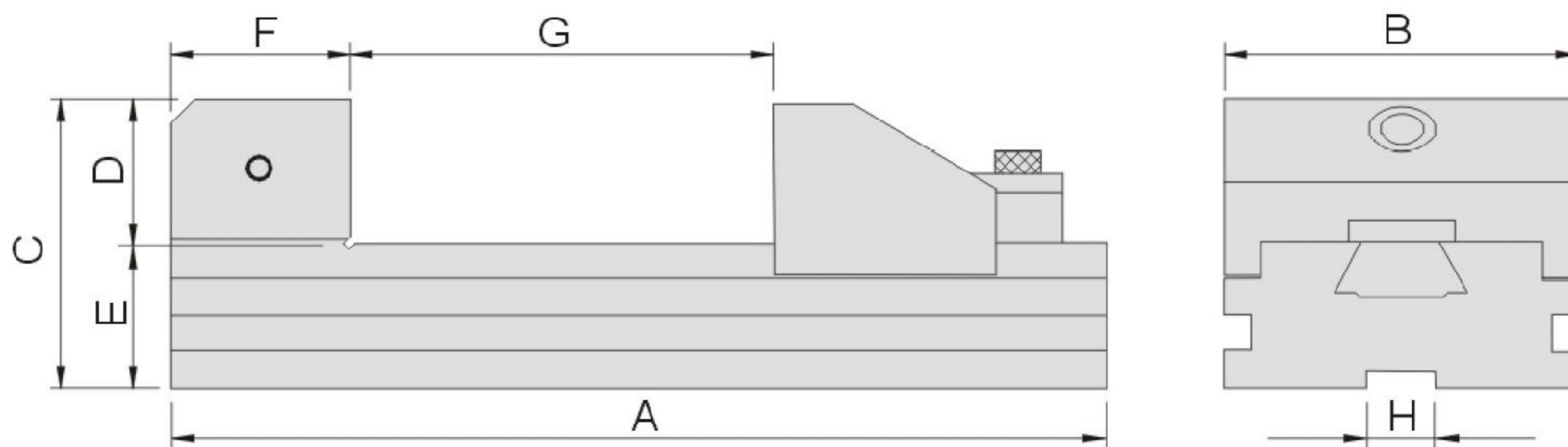
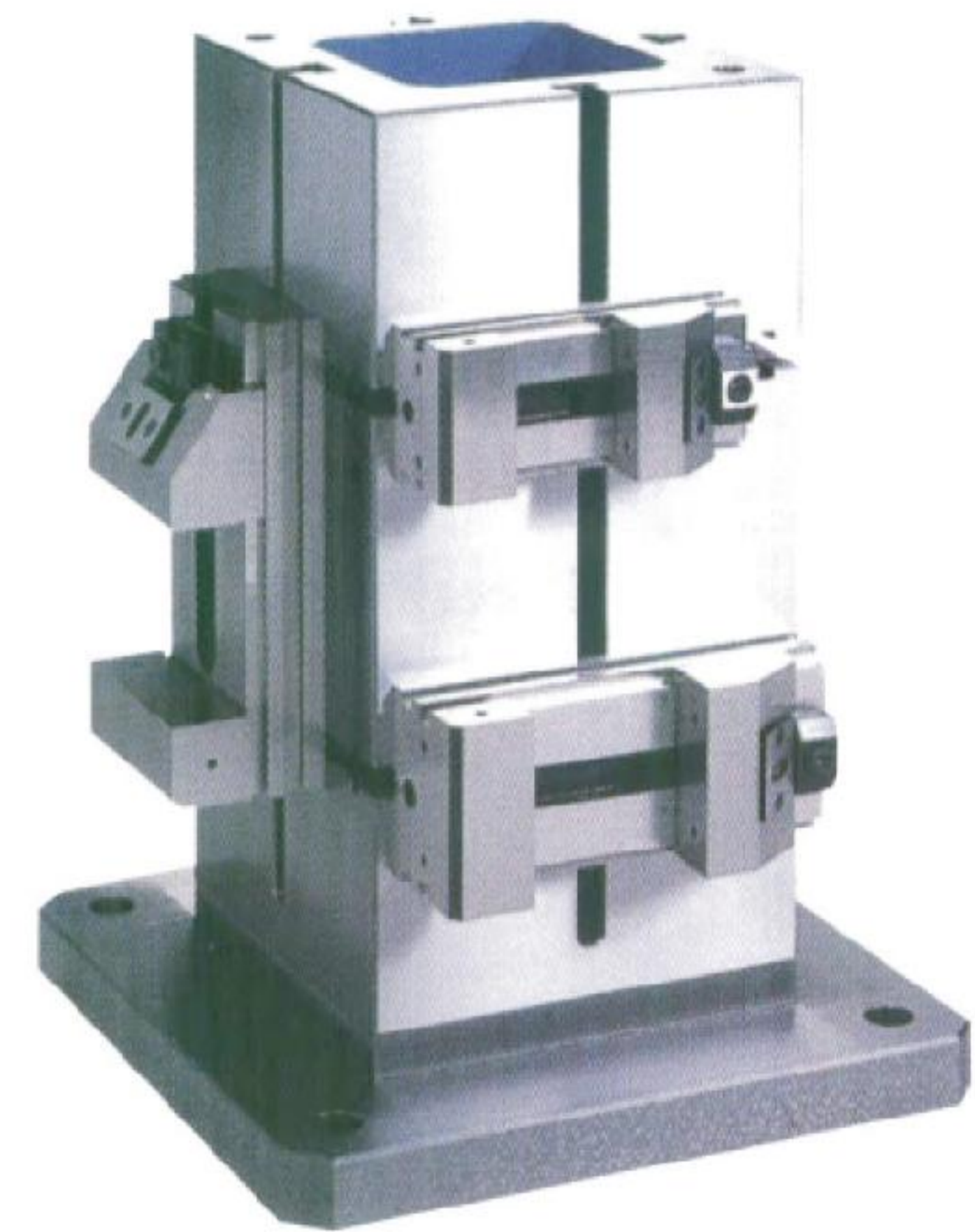

Unit:mm

Order No.	Model	A	B	C	D	E	F	G	H	N.W.
65000-60	LK60	180	60	55	27	28	35	0-80	14	3.0kg
65000-80	LK80	205	80	64	32	32	40	0-100	14	4.9kg
65000-100	LK100	250	96	82	40	42	45	0-125	14	9.7kg
65000-125	LK125	310	125	88	43	45	50	0-150	16	16.5kg