

Rapid Drills Throw-Away Inserts

Dx4 捨棄式快速鑽頭

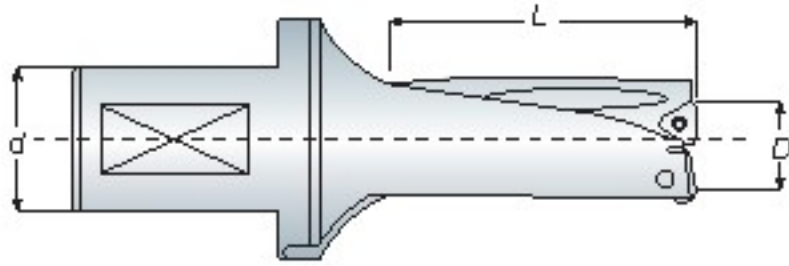

Model No.	Insert	d	D	L (Dx4)	Screw	Wrench
14WCMX	WCMX030208	32	14	56	M2.5x0.45	T8
16WCMX			16	64		
19WCMX			19	76		
20WCMX			20	80		
21WCMX			21	84		
22WCMX			22	88		
23WCMX			23	92		
24WCMX			24	96		
25WCMX	WCMT050308	32	25	100	M3.0x0.5	T10
26WCMX			26	104		
27WCMX			27	108		
28WCMX			28	112		
29WCMX			29	120		
34WCMX	WCMT06T308	34	136	M3.5x0.6	T15	
39WCMX	WCMT06T308	40	39	156	M3.5x0.6	T15
41WCMX			41	164		
43WCMX	WCMT080412	40	43	172	M4.0x0.7	T15
44WCMX			44	176		
47WCMX			47	188		
50WCMX			50	200		
54WCMX			54	216		
59WCMX	WCMT06T308	59	236	M3.5x0.6	T15	

Unit: mm

WCMX

Accessories



- Insert must be ordered separately.
- 刀片為另購品

Modular Concentricity Test Gauge

三點組合模具

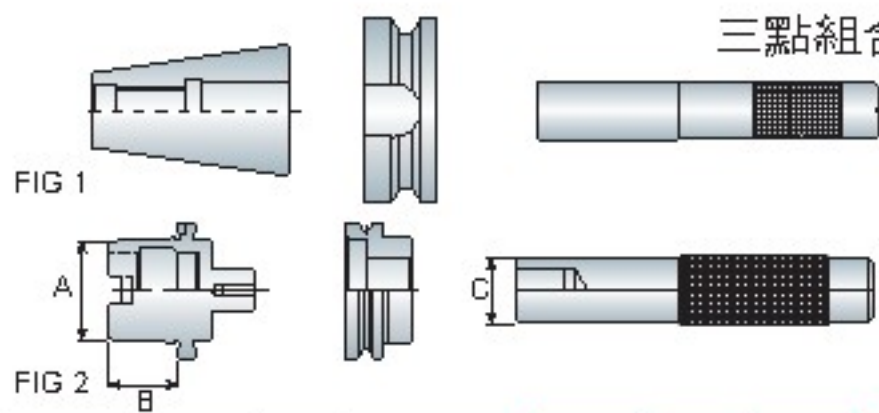

Model No.	FIG.	Taper Shank	A	B	C	Weight (kg)
BT30 A T C	1	MAS403-BT	-	-	-	0.60
BT40 A T C			-	-	-	1.30
BT50 A T C			-	-	-	4.30
SK30 A T C	1	SK-DIN69871A	-	-	-	0.60
SK40 A T C			-	-	-	1.10
SK50 A T C			-	-	-	3.40
CAT30 A T C	1	CAT	-	-	-	0.60
CAT40 A T C			-	-	-	1.10
CAT50 A T C			-	-	-	3.40
HSK50A A T C	2	HSK	50	25	25	1.10
HSK63A A T C			63	32	30	1.70
HSK100A A T C			100	50	40	4.70

Unit: mm

A.T.C.

FIG 1



FIG 2



- Use for test the A.T.C. device of machine center.