

**SK**  
series  
DIN 69871A

**APU**

## Drill Chuck Holder

直截式鑽夾頭刀桿

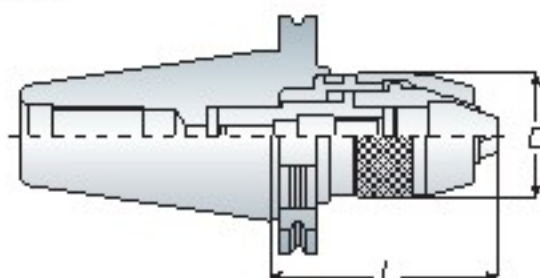

- The shank and keyless drill chuck are combined together so that to avoid the drill chuck slipping out for heavy-duty and high-speed cutting.
- Wrench is attached for each APU drill chuck holder.
- APU 刀桿和鑽夾頭結為一體，可避免鑽頭於高速及重切削時掉落或鬆脫。
- 每支 APU 刀桿均附 1 支扳手。

Model No.	Clamping Range	D	L		Weight (kg)
			Min.	Max.	
SK30APU08-063	1~8	36.3	57	64.5	0.90
APU 13-100	1~13	51.5	88	99	1.60
SK40APU08-085	1~8	36.3	69	86.5	1.40
APU 13-100	1~13	51.5	88	99	1.80
APU 16-120	3~16	58	106	120	2.40
SK50APU 13-120	1~13	51.5	99	120	4.10
-170	1~13	51.5	159	170	5.20
APU 16-120	3~16	58	106	120	4.40
-180	3~16	58	166	180	5.50

Unit: mm

## Drill Chuck Holder - B Type

鑽夾頭刀桿 - B 型

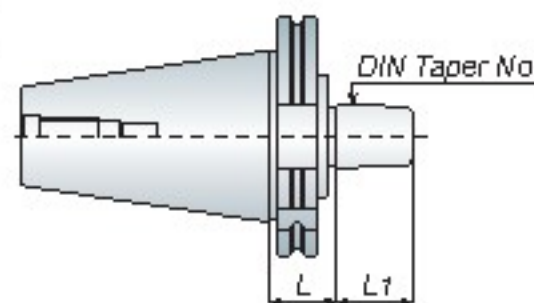

Model No.	DIN Taper No.	L	L1	Weight (kg)
SK40 B 16	B 16	32	24	1.20
B 18	B 18	32	32	1.30
SK50 B 16	B 16	43	24	2.80
B 18	B 18	43	32	3.00

Unit: mm