

BT / NT
series

AVC

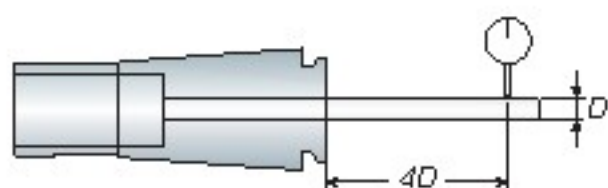

- When ordering, please specify the collet grade with A or AA.
For example: AVC12-08 AA.
- The tolerance of the tool shank should be h7.
- 請於訂購時註明 A 級或 AA 級
例：AVC12-08 AA
- AVC 筒夾夾持刀具柄徑公差為 h7



Collet

高精度立銑刀筒夾

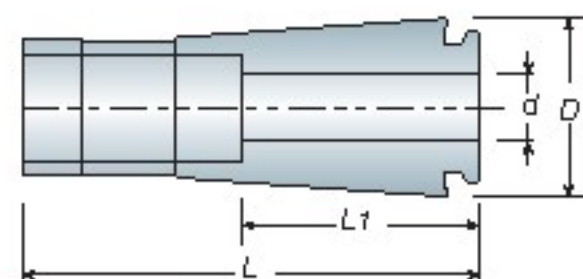

Model No.	d	D	L1	L	Weight (kg)
AVC06-02	2		14		0.02
AVC06-03	3		16		
AVC06-04	4	14	18	40	
AVC06-05	5		20		
AVC06-06	6		22		
AVC10-03	3		16		
AVC10-04	4		18		
AVC10-05	5	17	20	45.5	
AVC10-06	6		22		
AVC10-08	8		28		
AVC10-10	10		30		
AVC12-03	3		16		0.06
AVC12-04	4		18		
AVC12-05	5		20		
AVC12-06	6		22		
AVC12-07	7	21	25	54	
AVC12-08	8		28		
AVC12-09	9		28		
AVC12-10	10		30		
AVC12-11	11		30		
AVC12-12	12		32		

Unit: mm

筒夾等級 Collet Grade	跳動精度 / Runout - Max μ 4 倍直徑前 - 4xD
A 級	$\cong 10\mu$
AA 級	$\cong 5\mu$

Bearing Wrench

軸承扳手

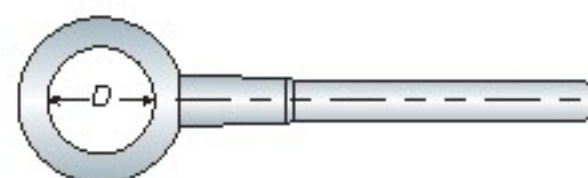

Model No.	D	Weight (kg)
WAVC06 (WASK10)	27	0.50
WAVC10 (WASK13)	33	0.65
WAVC12 (WASK16)	40	0.80

Unit: mm



Nut

螺帽

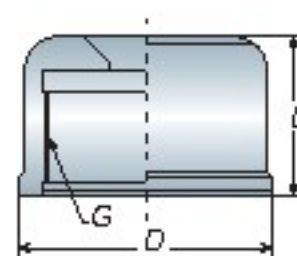

Model No.	D	L	G	Weight (kg)
WAVC06-NUT	27	22	M21.5x1.0P	0.05
WAVC10-NUT	33	20.5	M27x1.0P	0.08
WAVC12-NUT	40	28	M34x1.0P	0.10

Unit: mm

High Speed Collet Chuck

高轉速高精度立銑刀本體

AVC

ABT
Double-Face-Contact series

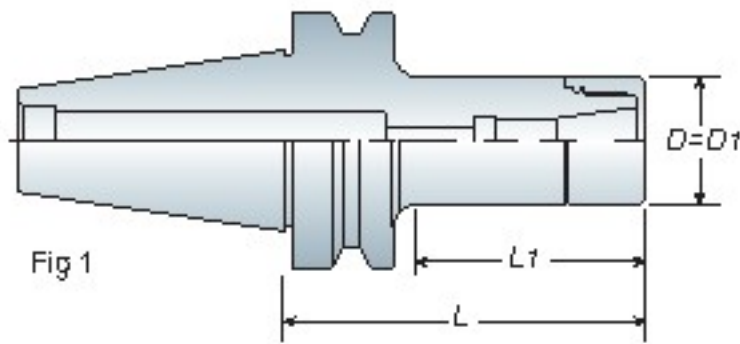

Fig 1

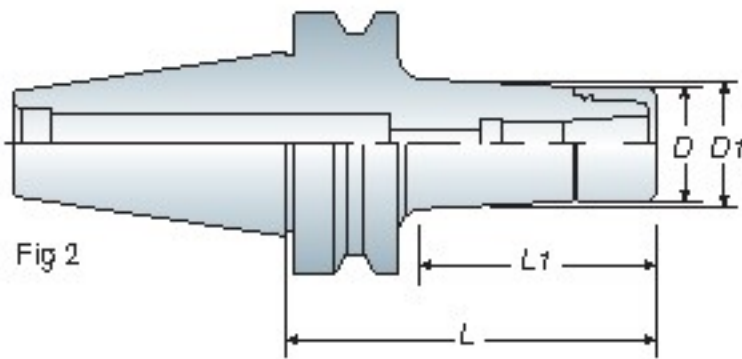

Fig 2



Through collets
筒夾出水

Features

- AVC Long type collet with angle 8° increase clamping force and cutting rigidity and precision.
- Special nut design provides better cutting conditions and reducing cutting vibrations.
- Wrench must be ordered separately.
- Max Speed: 30,000 r.p.m G2.5
- ABT-AVC is produced by order.
- 8° 長筒夾設計提升高夾持力，高剛性及高精度
- 刀桿柄壁的增厚設計大幅提升切削剛性
- 螺帽獨特設計可降低高轉速切削時的風阻及噪音並提升工作效能
- AVC 扳手為另購品
- 最高轉速可達 30,000 r.p.m G2.5
- ABT-AVC 為訂單生產品

Model No.	FIG.	Clamping Range	D	D1	L	L1	Weight (kg)
ABT30 AVC06-060	2	2~6	27	29	60	35	0.60
AVC10-060	1	3~10	33	33	60	40	0.70
AVC12-060	1	3~12	40	40	60	37	0.70
ABT40 AVC06-090	2	2~6	27	31	90	60	1.35
AVC10-090	2	3~10	33	40	90	65	1.50
AVC12-090	2	3~12	40	44	90	60	1.60
ABT50 AVC06-105	2	2~6	27	32	105	62	4.10
-165	2	2~6	27	38	165	122	4.50
AVC10-105	2	3~10	33	41	105	70	4.30
-165	2	3~10	33	47	165	130	4.80
AVC12-105	2	3~12	40	44	105	62	4.30
-165	2	3~12	40	51	165	122	5.10

Unit: mm



P21- AVC Collet

P21- AVC Nut

P21- Wrench