

SK
series
DIN 2080

APU



- The shank and keyless drill chuck are combined together so that to avoid the drill chuck slipping out for heavy-duty and high-speed cutting.
- Wrench is attached for each APU drill chuck holder.
- APU 刀桿和鑽夾頭結為一體，可避免鑽頭於高速及重切削時掉落或鬆脫
- 每支 APU 刀桿均附 1 支扳手

Drill Chuck Holder

直截式鑽夾頭刀桿

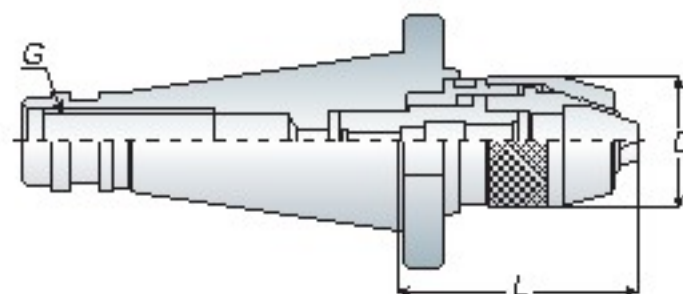

Model No.	Clamping Range	D	L		G	Weight (kg)
			Min.	Max.		
SK40 APU08-075	1~8	36.3	69	76.5	M16	1.30
APU13-100	1~13	51.5	88	99	M16	1.90
APU16-120	3~16	58	106	120	M16	2.30
SK50 APU08-085	1~8	36.3	80	87.5	M16	3.50
APU13-110	1~13	51.5	99	110	M16	3.80
-170	1~13	51.5	159	170	M24	4.50
APU16-120	3~16	58	106	120	M24	4.20
-180	3~16	58	166	180	M24	5.50

Unit: mm



- Keyless drill mount must be ordered separately.
- 鑽夾頭為另購品

Drill Chuck Holder - B Type

鑽夾頭刀桿 - B 型

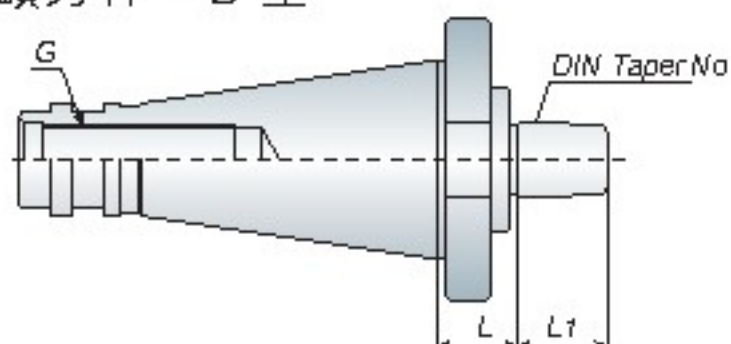

Model No.	DIN Taper No.	L	L1	G	Weight (kg)
SK40 B12	B12	15	18.5	M16	1.00
B16	B16	17	24	M16	1.00
B18	B18	17	32	M16	1.10
SK50 B16	B16	20	24	M24	2.50
B18	B18	20	32	M24	2.70

Unit: mm