

BT / NT
series

BCK

Micro Boring Head

大孔徑精搪刀頭

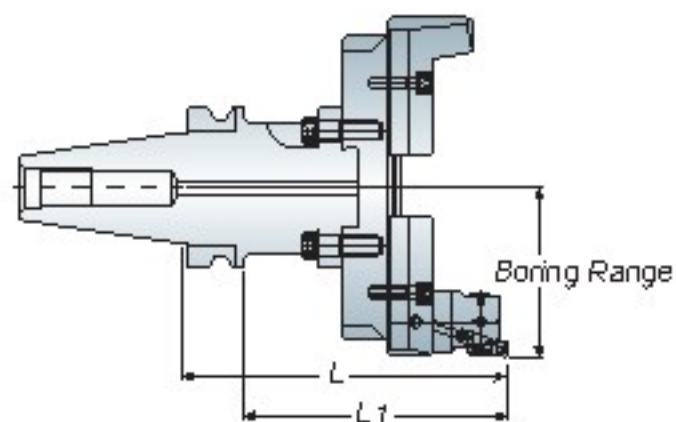

型號 Model No.	搪孔範圍 Boring Range		適用刀桿 BST Holder 	L	L1	BCK 橫向滑板 Extension Slide 	BCK 微調滑塊 Finish Slide 	平衡滑塊 Balance Slide 	精搪頭 Boring Head BCK41	刀片 Insert 
	Min.	Max.								
BCK200	200	300	BT50 BST 100 BT50 BST 150	200 250	165 215	ES-BCK200	FS200	BS200	BCK41	TC..1102
BCK300	300	400	BT50 BST 200 BT50 BST 250	300 350	265 315	ES-BCK300				
BCK400	400	500	BT50 BST 300	400	365	ES-BCK400				
BCK500	500	600	BT50 BST 350	450	415	ES-BCK500				

Unit: mm

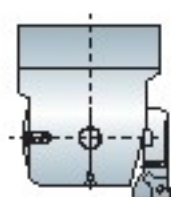

標準配件
BCKH4-1



另購品
BCKH4-2
+Ø9



另購品
BCKH4-3
+Ø11

- To use with H#-2&3 insert holder could extend the boring range.
- 使用 H#-2&3 刀片座，可擴大加工範圍

反搪示意圖
Back Boring

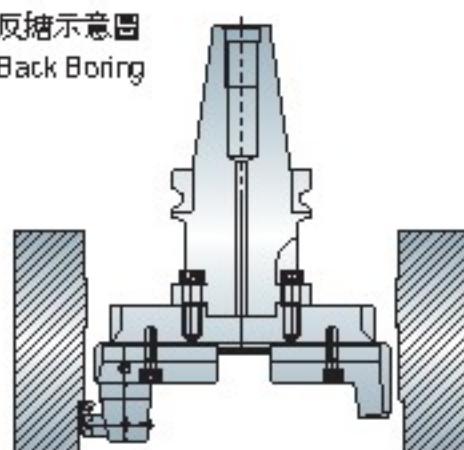

外搪示意圖
Turning

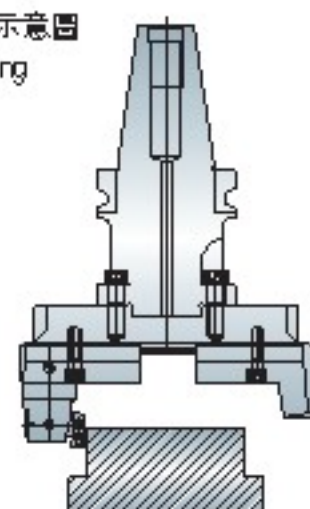

Square Boring Holder

方型精搪刀桿

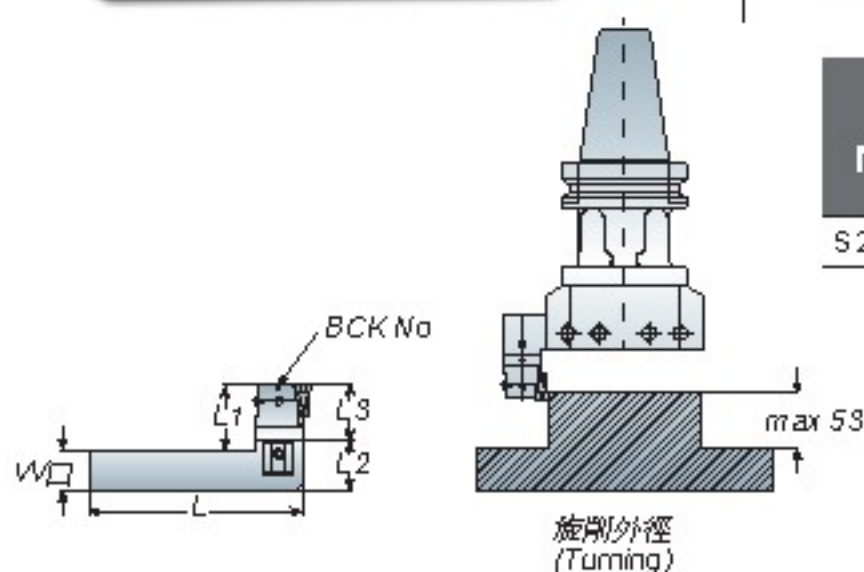

型號 Model No.	L	L1	L2	L3	W □	精搪頭 Boring Head	刀片 Insert
S 25-BCK32-135	135	56	41	40	25	BCK32	TP.0802

Unit: mm

BT / NT
series

BST

Adjustable Balance Cutter Tool Holder

大口徑雙刃粗搪刀桿

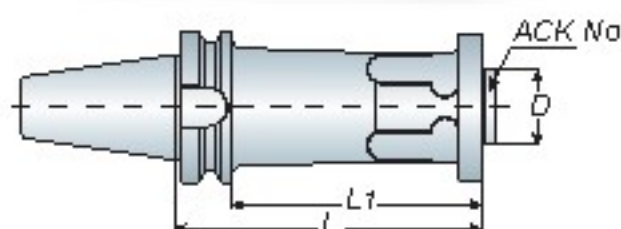

Model No.	D	L	L1	ACK Cutter No.	Weight (kg)
BT50 BST100	50	100	65		5.00
BST125	50	125	90		5.30
BST150	50	150	115		6.70
BST175	50	175	140	ACK120	7.30
BST200	50	200	165	ACK160	7.60
BST225	50	225	190	ACK200	8.30
BST250	50	250	215	ACK300	9.50
BST275	50	275	240	ACK400	9.90
BST300	50	300	265		10.80
BST350	50	350	315		13.50
BST400	50	400	365		14.40

Unit: mm

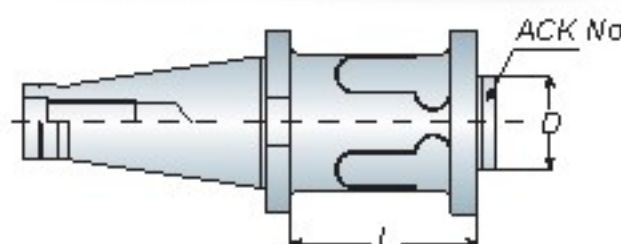

Model No.	D	L	ACK Cutter No.	Draw Bolt	Weight (kg)
NT50 BST100	50	100			4.80
BST125	50	125			5.10
BST150	50	150			6.50
BST175	50	175	ACK120		6.80
BST200	50	200	ACK160		7.30
BST225	50	225	ACK200	1" 8 M24x3.0P	7.90
BST250	50	250	ACK300		8.70
BST275	50	275	ACK400		9.00
BST300	50	300			9.90
BST350	50	350			12.60
BST400	50	400			13.50

Unit: mm

- When ordering, please specify the draw bolt with inch size or metric size.
- 請於訂購時，確認刀桿為英制或公制

ACK

Adjustable Balance Cutter

大口徑雙刃粗搪刀頭 Ø120 ~ Ø500mm

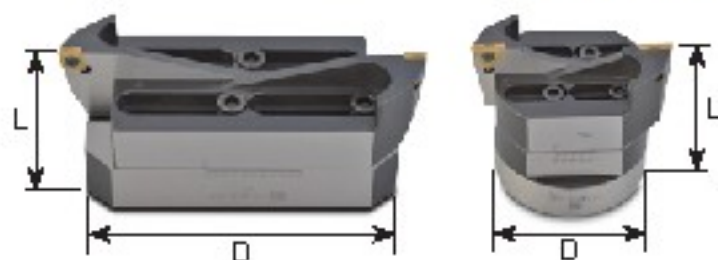

- Balance cutter with two insert holders that reduce vibration and steady for cutting.
- When ordering, please specify the cutter with AA or AB type.
For example: ACK200 (AB-T)
- 刀頭雙層對稱式刀座設計可於加工時降低震動、斷屑容易
- 請於訂購時，確認刃高為 AA 或 AB 型
例：ACK200 (AB-T)

Model No.	Boring Range		D	L	Tool Holder	Weight (kg)
	Min.	Max.				
ACK120-C	120	164	95	95	BST	3.80
ACK120-T	120	164	95	95		3.80
ACK160-C	160	204	95	95		4.80
ACK160-T	160	204	95	95		4.80
ACK200-C	200	300	80	75		5.20
ACK200-T	200	300	80	75		5.20
ACK300-C	300	400	80	75		7.90
ACK300-T	300	400	80	75		7.90
ACK400-C	400	500	80	75		9.70
ACK400-T	400	500	80	75		9.70

Unit: mm

Insert For ACK Adjustable Balance Cutter

刀片 - ACK 粗搪刀頭適用

TIPS

BT / NT
series

CCMT

ACK Cutter No.	Insert	Screw	Wrench
ACK19 / ACK25	CC.. 060208	MS2506A	T9
ACK32	CC.. 060208	MS2506A	T9
ACK40 / ACK52	CC.. 09T308	MS4011A	T15
ACK68 / ACK90 / ACK120 / ACK160 ACK200 / ACK300 / ACK400	CC.. 120408	MS5011A	T20

TCMT

ACK Cutter No.	Insert	Screw	Wrench
ACK32	TC.. 110208	MS2506A	T9
ACK40 / ACK52 / ACK68	TC.. 16T308	MS4011A	T15
ACK90 / ACK120 / ACK160 / ACK200 ACK300 / ACK400	TC.. 220408	MS5011A	T20

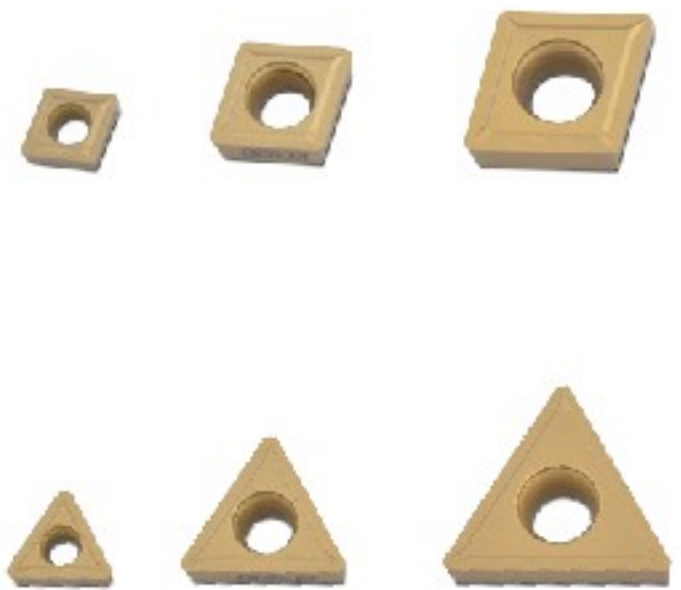

- For working material, the inserts divides the most common used 3 types: 1. IRON: KC850, 2. CAST IRON: KC5010, 3. ALUM: KC313.
- When ordering, please specify the material code. For example: CCMT 060208 KC850
- 依加工材質，刀片可區分為三種：
1. 鐵：KC850，2. 鑄鐵：KC5010，3. 鋁：KC313
- 訂購時，請註明材質編號
例：CCMT 060208 KC850

ACK Cutter No.	Suitable Holder	D	L	Screw
ACK19	ACK1	11	5	3x6
ACK25	ACK2	14	6	3x6
ACK32	ACK3	18	7	4x8
ACK40	ACK4	22	9	4x12
ACK52	ACK5	28	12	5x15
ACK68	ACK6	36	15	6x20
ACK90	ACK6	36	15	8x25
ACK120	BST	50	72	8x30
ACK160	BST	50	72	8x45
ACK200	BST	50	72	8x60
ACK300	BST	50	72	8x60
ACK400	BST	50	72	8x60

ACK19~90 TYPE

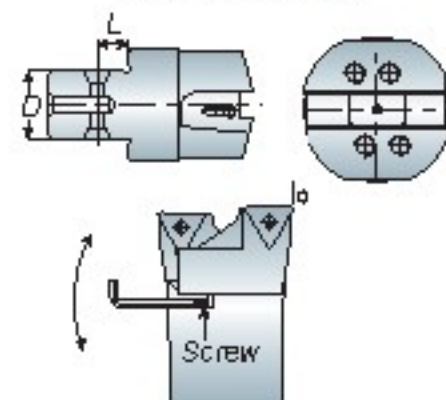

ACK120~400 TYPE

