

BT / NT
series

BST



- The boring range is from 150 ~ 600mm
- BST boring block must be ordered separately.
- BST 粗搪刀桿之搪孔範圍為 150 ~ 600mm
- BST 刀盤為另購品



- The boring range is from 150 ~ 600mm
- When ordering, please specify the draw bolt with inch size or metric size.
- BST boring block must be ordered separately.
- BST 粗搪刀桿之搪孔範圍為 150 ~ 600mm
- 請於訂購時，確認刀桿為英制或公制
- BST 刀盤為另購品



- Throw away boring cutter must be ordered separately and the degree must be 90° .
- When ordering the throw away boring cutter, please check the W □ .
- 捨棄式搪刀架為另購品，內徑搪孔角度需為 90°
- 請於訂購捨棄式搪刀架時，確認 W □ 尺寸



P7 6-Boring Cutter

Large Size Boring Holder

大孔徑粗搪刀桿

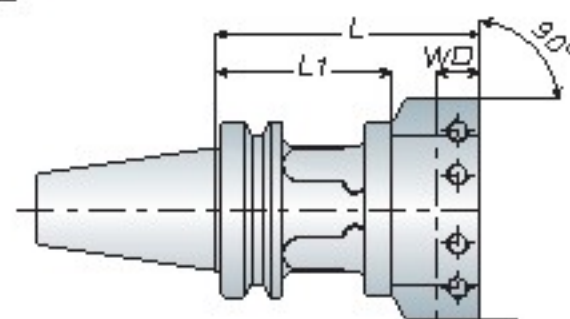

Model No.	L1	L	Weight (kg)
BT50 BST100	100	150	5.00
BST150	150	200	6.70
BST200	200	250	7.60
BST250	250	300	9.50
BST300	300	350	10.80
BST350	350	400	13.50

Unit: mm

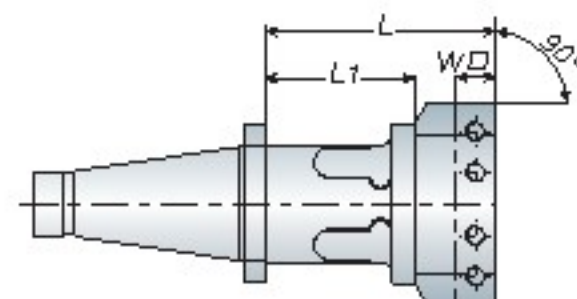
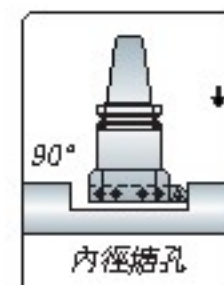

Model No.	L1	L	Draw Bolt	Weight (kg)
NT50 BST100	100	150	1" 8 M24x3.0P	4.80
BST150	150	200		6.50
BST200	200	250		7.30
BST250	250	300		8.70
BST300	300	350		9.90
BST350	350	400		12.60

Unit: mm

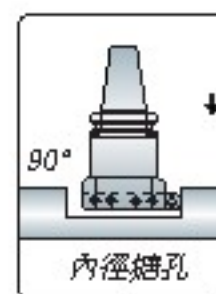

Boring Block

刀盤

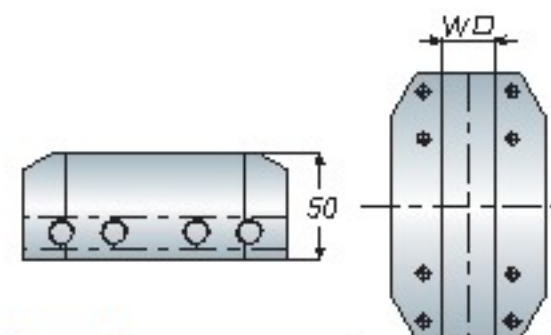

Model No.	Boring Range		W □	Weight (kg)
	Min.	Max.		
BST-125	150	200	1 9/25	3.20/2.90
BST-150	170	250	1 9/25	3.80/3.50
BST-200	220	300	1 9/25	5.30/4.80
BST-250	270	350	1 9/25	6.20/5.60
BST-300	320	450	1 9/25	7.40/6.90
BST-400	450	600	1 9/25	10.00/9.20

Unit: mm