

Accessories

EDGE FINDER



- Nonmagnetic and made of ceramic.
- 具有不導磁之特性並使用全陶瓷之材質



- The edge finder has made rust prevention processing.
- 迴轉式尋邊器已做特殊防鏽處理

Mechanical Type

機械式尋邊器

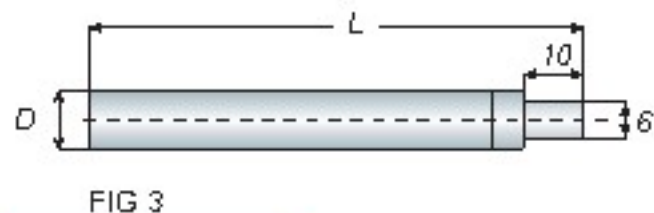
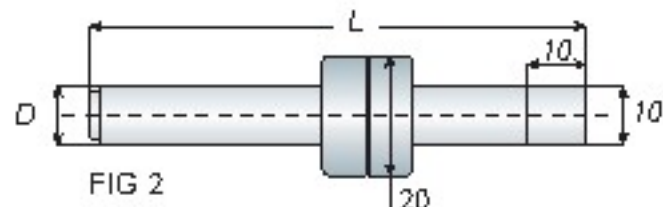
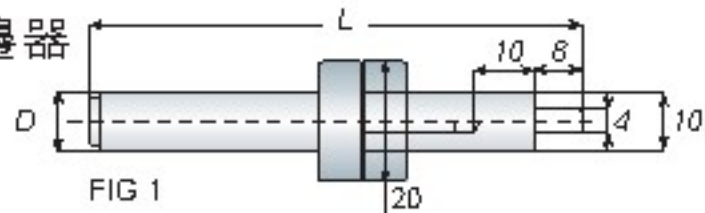

Model No.	FIG.	D	L	Weight (kg)
PM10-FIG 1	1	10	90	0.10
PM10-FIG 2	2	10	82.8	0.10
ME-610	3	10	65	0.05

Unit: mm

Ceramic Type

陶瓷尋邊器

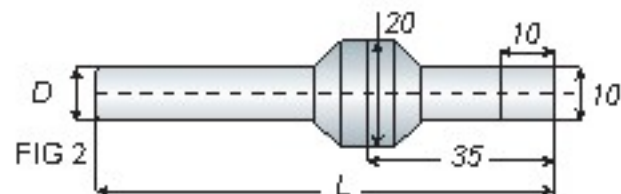
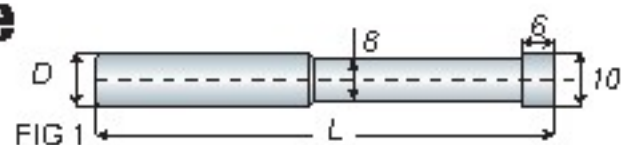

Model No.	FIG.	D	L	Weight (kg)
WH-1010	1	10	86	0.05
WH-1020	2	10	83	0.10

Unit: mm

Rotary Type

迴轉式尋邊器

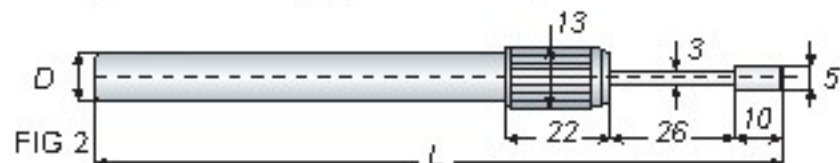
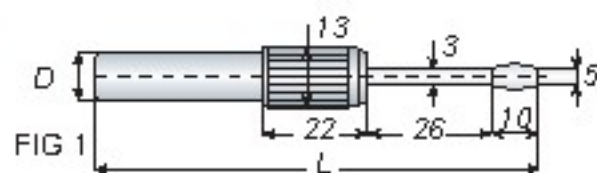

Model No.	FIG.	D	L	Weight (kg)
ME-P1	1	10	93	0.05
ME-P2	2	10	144	0.10
ME-P1+P2	-	-	-	0.15

Unit: mm

High Sensitive Electronic Edge Finder

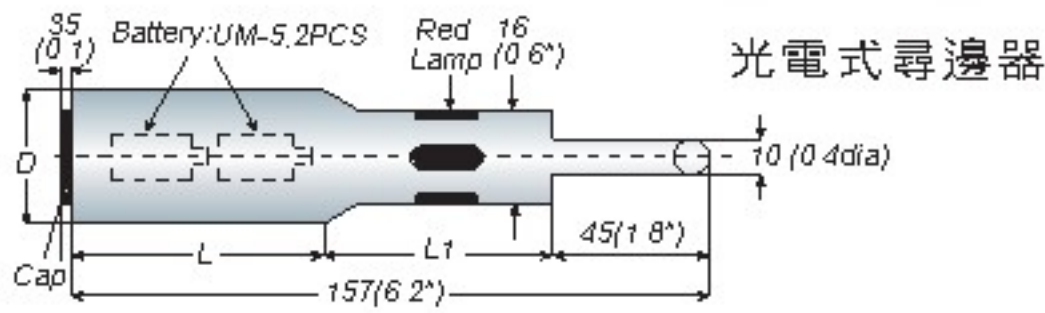

光電式尋邊器

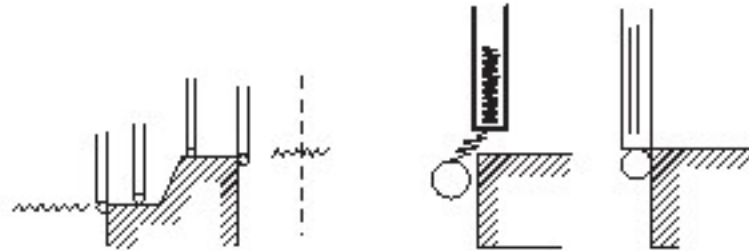

- Easy location of work face, O.D/I.D
- Spring-retained sensor ball protects the unit against over-run.

Model No.	D	L	L1	Weight (kg)
PM20	20	77	35	0.35
PM32	32	71	41	0.70
PM3/4"	19.05 (3/4")	77	35	0.35
PM1-1/4"	31.75 (1-1/4")	71	41	0.70

Unit: mm

PM

Accessories



- High sensitive edge sensor with red LED lamp and beep sound.
- Instant indication by red LED lamp at very light contact of sensor ball with workpiece.

Taster-Haimer

萬向尋邊器

Model No.	Code No. (HAIMER)	Accuracy	Weight (kg)
3D Taster (3D 尋邊器)	80.360.00	0.01 mm	1.00
3D Short Needle (3D 短針)	80.362.00	-	0.01
3D Long Needle (3D 長針)	80.363.00	-	0.02

Unit: mm

3D

