

ABT
Double-Face-Contact series

FMA
FMB

Face Mill Holder

平面銑刀桿

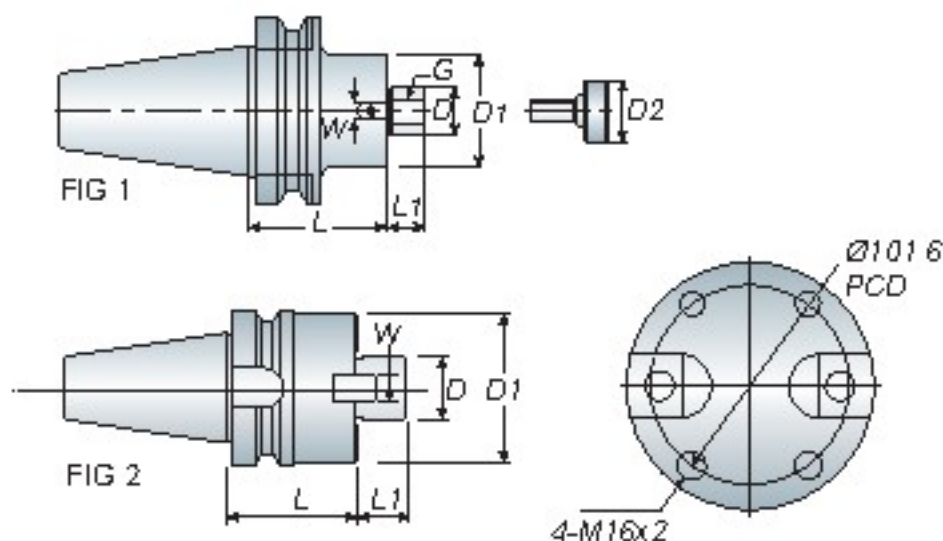

- Face mill holder equips with screw and drive keys to assemble the face mill cutter to the holder.
- Face mill cutter must be ordered separately.
- Max speed: 30,000 r.p.m G2.5
- ABT-FMA/FMB is produced by order.
- 每支 FMB 面銑刀桿均附有螺絲及擋耳以裝配面銑刀盤使用
- 面銑刀盤為另購品
- 最高轉速可達 30,000 r.p.m G2.5
- ABT-FMA/FMB 為訂單生產品



P174/175-
Face Mill Cutter

Model No.	FIG.	D	D1	D2	L	L1	W	G	Weight (kg)
ABT30 FMA25 4-045	1	25.4	45	33	45	20	9.5	M12	0.90
FMA31 75-045	1	31.75	58	40	45	22	12.7	M12	1.30
ABT40 FMA25 4-045/060	1	25.4	60	33	45/60	20	9.5	M12	1.70/2.00
FMA31 75-045/060	1	31.75	70	40	45/60	22	12.7	M12	1.80/2.30
FMA38 1-045	1	38.1	85	50	45	23	15.9	M16	2.60
ABT50 FMA25 4-045/105	1	25.4	60	33	45/105	20	9.5	M12	4.20/5.30
FMA31 75-045/105	1	31.75	70	40	45/105	22	12.7	M12	4.40/6.20
FMA38 1-045/075	1	38.1	85	50	45/75	23	15.9	M16	4.50/5.90
FMA50 8-045	1	50.8	95	65	45	24	19.05	M16	5.00
FMA47 625-075	2	47.625	128.57	-	75	32	25.4	-	8.30

Unit: mm

Model No.	FIG.	D	D1	D2	L	L1	W	G	Weight (kg)
ABT30 FMB22-045	1	22	56	-	45	18	10	M10	0.80
FMB27-045	1	27	64	32	45	20	12	M12	1.00
ABT40 FMB22-045/060	1	22	48	-	45/60	18	10	M10	1.40/1.60
FMB27-045/060	1	27	60	32	45/60	20	12	M12	1.70/2.00
FMB32-045	1	32	63	41	45	21	14	M16	1.80
FMB40-045/060	1	40	68	47	45/60	23	16	M16	2.00/2.70
ABT50 FMB22-045/105	1	22	48	-	45/105	18	10	M10	4.00/4.80
FMB27-045/105	1	27	65	32	45/105	20	12	M12	4.30/5.80
FMB32-045/105	1	32	73	41	45/105	21	14	M16	4.40/6.60
FMB40-045	1	40	85	47	45	23	16	M16	4.60
FMB60-075	2	60	128.57	-	75	32	25.4	-	7.30

Unit: mm