



Quick Change Tapping Chuck



VERTEX®

European Type

SPECIAL!

**SAFETY !
QUICK !**



TAPPING CHUCKS

QUICK CHANGE TAPPING CHUCKS (with length compensation)

MAS-BT-30, 40, 50 Shank / DIN69871A SK-40, 50 / ST-20, 32 / MT-2, 3, 4

- Tension and compression feature allows taps to follow their own thread lead.
- With extreme light compression compression and tension operated by ball cage.



Quick Change Tapping Chucks

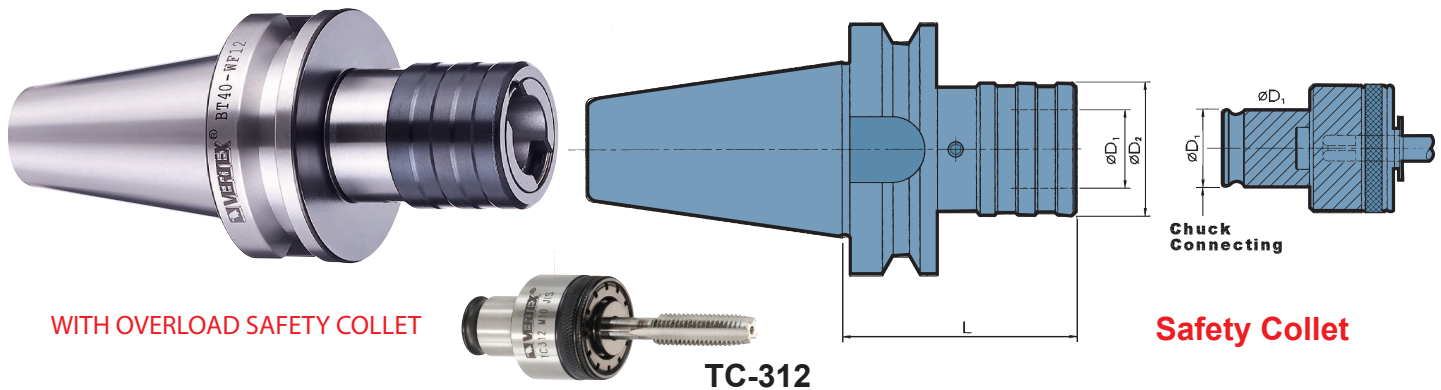

- Tension and compression feature allows taps to follow their own thread lead.
- With extreme light compensation compression and tension operated by ball cage.

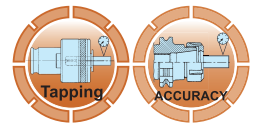

WF-BT30/BT40/SK30/SK40 LENGTH COMPENSATION TYPE

ORDER NO.	Thread Size	L	$\varnothing D_1$ Chuck Connecting DIA.	$\varnothing D_2$	Length Compensation		Tapping Collets	WEIGHT (kg)	CODE NO.
					Compression	Tension			
BT30-WF12	M2-M14	70	$\varnothing 19$	36	7.5	7.5	TC-312	0.8	3404-050A
BT40-WF12	M2-M14	75	$\varnothing 19$	36	7.5	7.5	TC-312	1.3	3404-050
SK40-WF12								1.3	3404-051
BT30-WF20	M5-M24	94	$\varnothing 31$	53	12.5	12.5	TC-820	1.3	3404-052A
BT40-WF20	M5-M24	95	$\varnothing 31$	53	12.5	12.5	TC-820	1.8	3404-052
SK40-WF20	M5-M24	95	$\varnothing 32$	53	12.5	12.5	TC-820	1.8	3404-053

※Tapping Collet Reducer Adapter : TC820 / TC312-AD



Quick Change Tapping Chucks

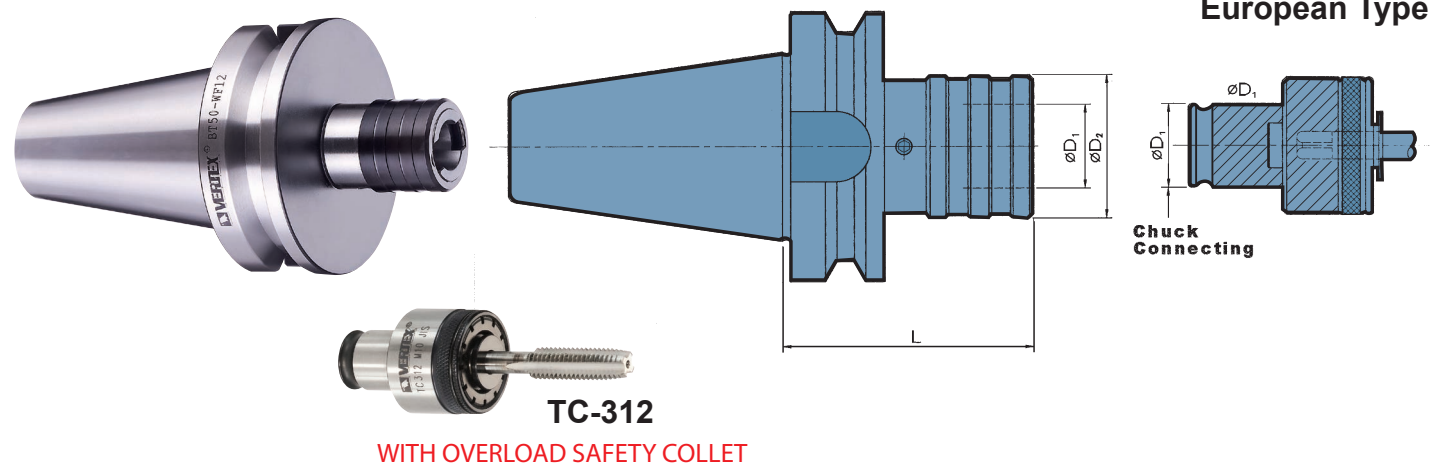

- Tension and compression feature allows taps to follow their own thread lead.
- With extreme light compensation compression and tension operated by ball cage.

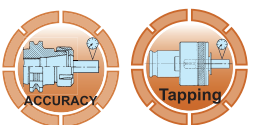

WF-BT50/SK50 LENGTH COMPENSATION TYPE

ORDER NO.	Thread Size	L	$\varnothing D_1$ Chuck Connecting DIA.	$\varnothing D_2$	Length Compensation		Collets	WEIGHT (kg)	CODE NO.
					Compression	Tension			
BT50-WF12	M2-M14	85	$\varnothing 19$	36	7.5	7.5	TC-312	4	3404-060
SK50-WF12								4	3404-061
BT50-WF20	M5-M24	105	$\varnothing 31$	53	12.5	12.5	TC-820	4.1	3404-062
SK50-WF20								4.1	3404-063
BT50-WF33	M14-M36	142	$\varnothing 48$	78	20	20	TC-1433	5.8	3404-064

※Tapping Collet Reducer Adapter : TC820 / TC312-AD TC1433 / TC820-AD



Quick Change Tapping Chucks



QUICK CHANGE TAPPING CHUCKS (with length compensation)

STRAIGHT SHANK

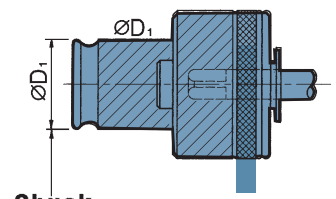
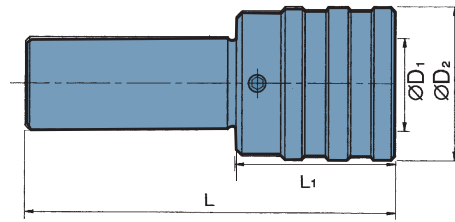

Chuck Connecting

WITH OVERLOAD SAFETY COLLET



TC-312

- Tension and compression feature allows taps to follow their own thread lead.
- With extreme light compensation compression and tension operated by ball cage.

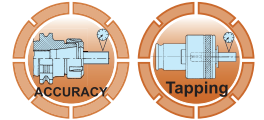

WF-ST LENGTH COMPENSATION TYPE

ORDER NO.	Thread Size	L	L1	ØD1 Chuck Connecting DIA.	ØD2	Length Compensation		Collets	WEIGHT (kg)	CODE NO.
						Compression	Tension			
ST20-WF12	M2-M14	105	40	Ø19	36	7.5	7.5	TC-312	0.4	3404-087
ST32-WF12									0.6	3404-088
ST20-WF20	M5-M24	120	65	Ø31	53	12.5	12.5	TC-820	1	3404-089
ST32-WF33	M14-M36	183	80	Ø48	78	20	15	TC-1433	2.7	3404-092

※Tapping Collet Reducer Adapter : TC820 / TC312-AD TC1433 / TC820-AD



Quick Change Tapping Chucks

Solid Type

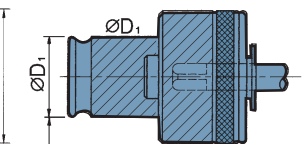
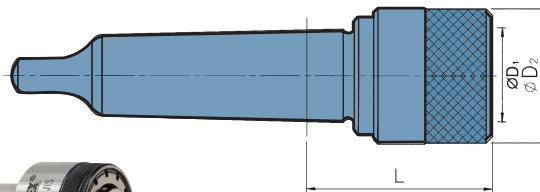

Chuck Connecting

WITH OVERLOAD SAFETY COLLET



TC-312

- Tension and compression feature allows taps to follow their own thread lead.
- With extreme light compensation compression and tension operated by ball cage.

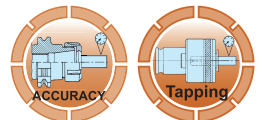

WF-MT LENGTH COMPENSATION TYPE

ORDER NO.	Thread Size	Morse Taper MT	L	ØD1 Chuck Connecting DIA.	ØD2	Length Compensation		Collets	WEIGHT (kg)	CODE NO.
						Compression	Tension			
MT2-WF12	M2-M14	MT2	47.5	Ø19	36	7.5	7.5	TC-312	0.4	3404-123
MT3-WF12		MT3							0.56	3404-123A
MT4-WF12		MT4							0.86	3404-123B
MT2-WF20	M5-M24	MT2	70	Ø31	53	12.5	12.5	TC-820	0.8	3404-124
MT3-WF20		MT3							0.96	3404-124A
MT4-WF20		MT4							1.5	3404-124B
MT3-WF33	M14-M36	MT3	103	Ø48	78	20	15	TC-1433	2.2	3404-125
MT4-WF33		MT4							2.76	

※Tapping Collet Reducer Adapter : TC820 / TC312-AD TC1433 / TC820-AD



Quick Change Tapping Chucks



QUICK CHANGE TAPPING CHUCKS (with length compensation)

MAS-BT SHANK / DIN69871A SHANK

- Tension and compression feature allows taps to follow their own thread lead.

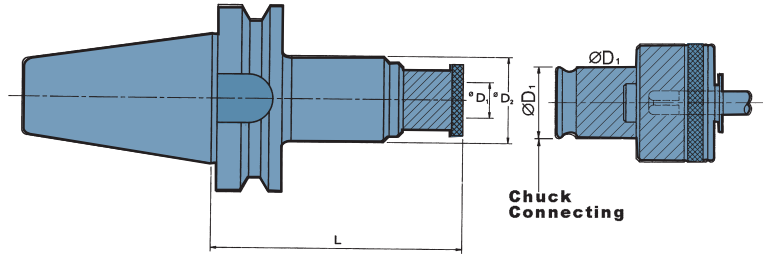

Chuck Connecting

WITH OVERLOAD SAFETY COLLET



TC-312

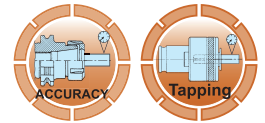

WFE-BT40 LENGTH COMPENSATION TYPE

ORDER NO.	Thread Size	L	ØD ₁ Chuck Connecting DIA.	ØD ₂	Length Compensation		Collets	WEIGHT (kg)	CODE NO.
					Compression	Tension			
BT40-WFE12-135	M2-M14	135	Ø19	46	15	20	TC-312	1.5	3404-070
BT40-WFE12-165		165						2.4	3404-072

※Tapping Collet Reducer Adapter : TC820 / TC312-AD TC1433 / TC820-AD



Quick Change Tapping Chucks

QUICK CHANGE TAPPING CHUCKS (with length compensation)

MAS-BT SHANK / DIN69871A SHANK

- Tension and compression feature allows taps to follow their own thread lead.

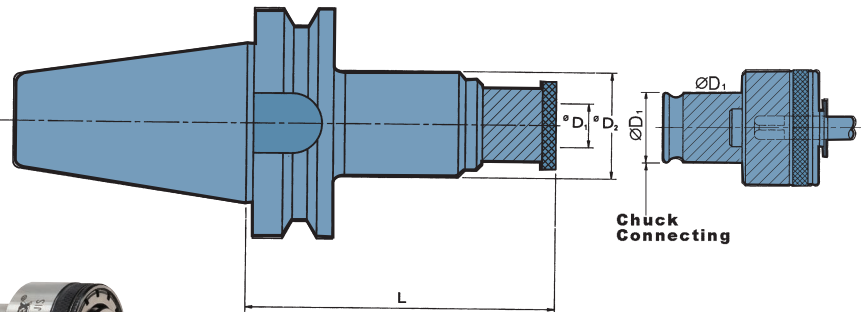

Chuck Connecting

WITH OVERLOAD SAFETY COLLET



TC-312

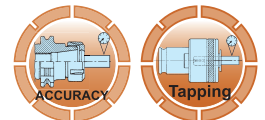

WFE-BT50 LENGTH COMPENSATION TYPE

ORDER NO.	Thread Size	L	ØD ₁ Chuck Connecting DIA.	ØD ₂	Length Compensation		Collets	WEIGHT (kg)	CODE NO.
					Compression	Tension			
BT50-WFE12-135	M2-M14	135	Ø19	46	15	20	TC-312	4.54	3404-080
BT50-WFE12-165		165						4.94	3404-082
BT50-WFE20-165	M5-M24	165	Ø31	58	15	15	TC-820	7	3404-084

※Tapping Collet Reducer Adapter : TC820 / TC312-AD TC1433 / TC820-AD



Quick Change Tapping Chucks



MSA-BT SHANK & DIN 69871A SHANK

Solid Type

- No tension or compensation stroke for use in synchronous tapping(rigid tapping) cycle.

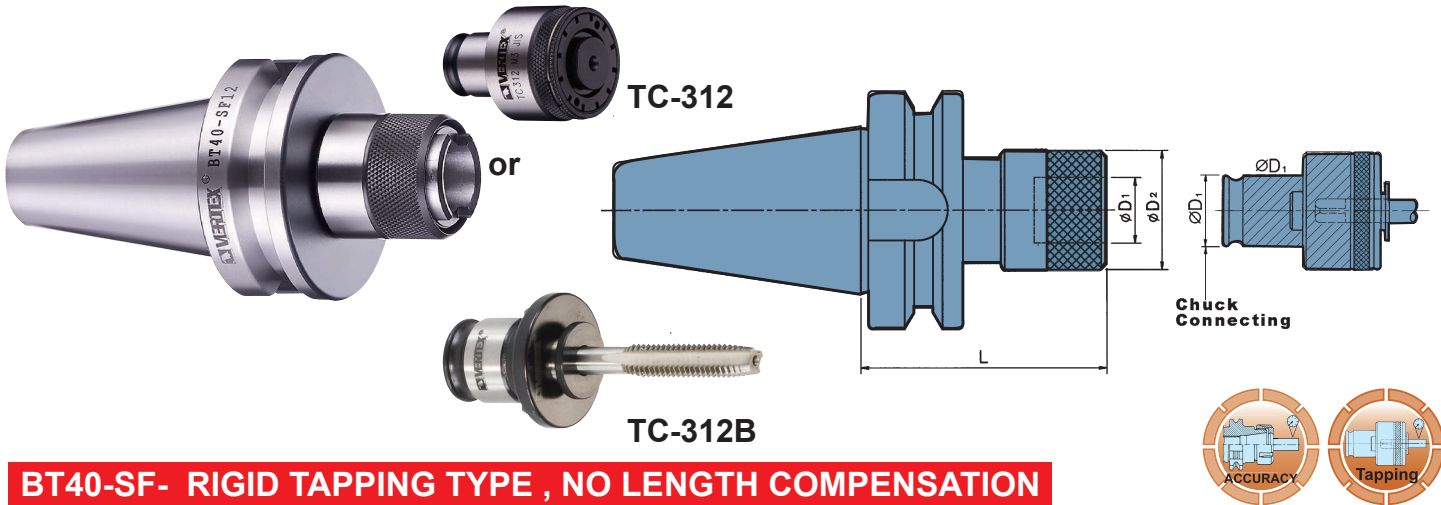

BT40-SF- RIGID TAPPING TYPE , NO LENGTH COMPENSATION

ORDER NO.	Thread Size	L	ØD1 Chuck Connecting DIA.	ØD2	Collets	WEIGHT (kg)	CODE NO.
BT40-SF12	M2-M14	72	Ø19	34	TC-312 TC-312B	1	3404-100
BT40-SF20	M5-M24	91	Ø31	50	TC-820 TC-820B	1.4	3404-102
BT40-SF33	M14-M36	130	Ø48	74	TC-1433 TC-1433B	3.5	3404-104

※Tapping Collet Reducer Adapter : TC820 / TC312-AD TC1433 / TC820-AD



Quick Change Tapping Chucks

MSA-BT SHANK & DIN 69871A SHANK

Solid Type

- No tension or compensation stroke for use in synchronous tapping(rigid tapping) cycle.

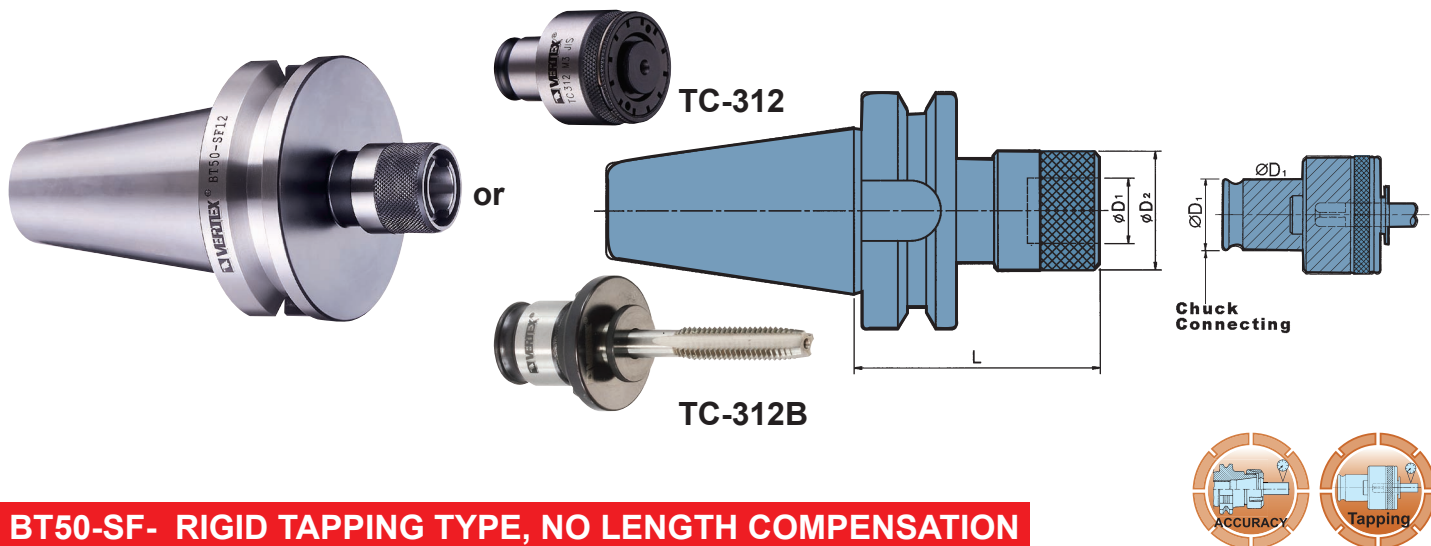

BT50-SF- RIGID TAPPING TYPE, NO LENGTH COMPENSATION

ORDER NO.	Thread Size	L	ØD1 Chuck Connecting DIA.	ØD2	Collets	WEIGHT (kg)	CODE NO.
BT50-SF12	M2-M14	78	Ø19	34	TC-312 TC-312B	3.6	3404-110
BT50-SF20	M5-M24	95	Ø31	50	TC-820 TC-820B	4	3404-112
BT50-SF33	M14-M36	142	Ø48	74	TC-1433 TC-1433B	5.6	3404-116

※Tapping Collet Reducer Adapter : TC820 / TC312-AD TC1433 / TC820-AD



Quick Change Tapping Chucks



QUICK CHANGE TAPPING CHUCKS

Solid Type

MORSE TAPER SHANK

- Tension and compression feature allows taps to follow their own thread lead.
- With extreme light compensation compression and tension operated by ball cage.

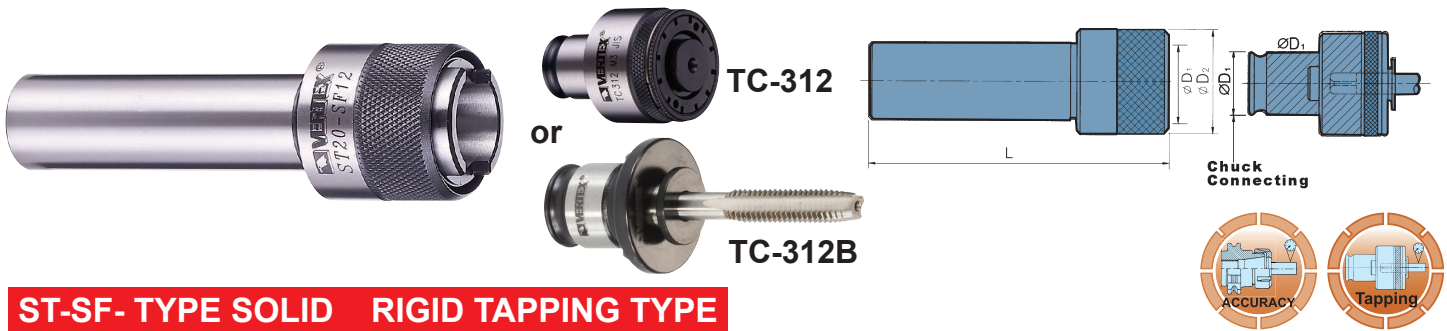

ST-SF- TYPE SOLID RIGID TAPPING TYPE

ORDER NO.	Thread Size	L	L1	ØD1 Chuck Connecting DIA.	ØD2	Collets	WEIGHT (kg)	CODE NO.
ST20-SF12	M2-M14	104	70	Ø19	34	TC-312	0.3	3404-140
ST32-SF12		106		Ø19		TC-312B	0.66	3404-140A
ST20-SF20	M5-M24	105		Ø31	50	TC-820	0.74	3404-141
ST32-SF20				Ø31		TC-820B	1.02	3404-141A
ST32-SF33	M14-M36	169	Ø48	76	TC-1433 TC-1433B	2.86	3404-142A	

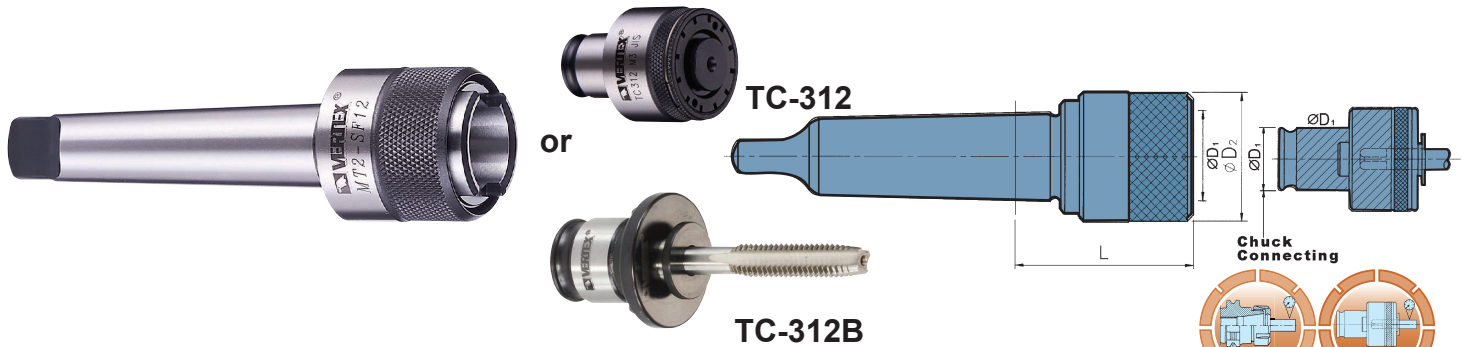

MT-SF- TYPE SOLID RIGID TAPPING TYPE, NO LENGTH COMPENSATION

ORDER NO.	Thread Size	Morse Taper MT	L	ØD1 Chuck Connecting DIA.	ØD2	Collets	WEIGHT (kg)	CODE NO.
MT2-SF12	M2-M14	MT2	45	Ø19	34	TC-312 TC-312B	0.3	3404-120
MT3-SF12		MT3					0.8	3404-120A
MT4-SF12		MT4	46			0.8	3404-120B	
MT2-SF20	M5-M24	MT2	70	Ø31	50	TC-820 TC-820B	0.6	3404-121A
MT3-SF20		MT3					0.8	3404-121
MT4-SF20		MT4	75			1.18	3404-121B	
MT3-SF33	M14-M36	MT3	99	Ø48	74	TC-1433 TC-1433B	0.84	3404-122A
MT4-SF33		MT4	99				2.2	3404-122

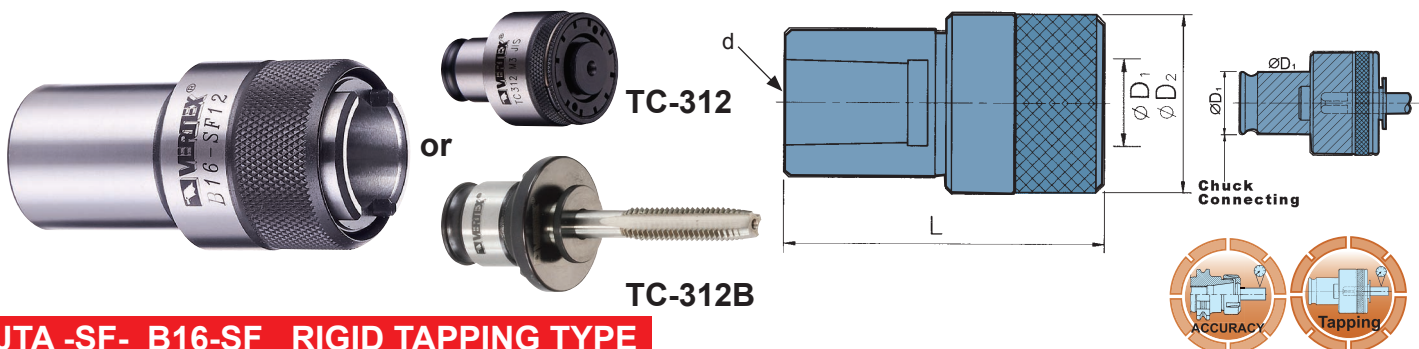

JTA-SF- B16-SF RIGID TAPPING TYPE

ORDER NO.	Thread Size	L	ØD1 Chuck Connecting DIA.	ØD2	d	Collets	WEIGHT (kg)	CODE NO.
JTA6-SF12	M2-M14	66	Ø19	32	JT6	TC-312 TC-312B	0.3	3404-130
B16-SF12					B16		0.22	3404-130A
B12-SF12					B12		0.2	3404-130B

※ Tapping Collet Reducer Adapter : TC820 / TC312-AD TC1433 / TC820-AD



Quick Change Tapping Chucks Set



Shank with length compensation

European Type

NEW



- Tension and compression feature allows taps to follow their own thread lead.
- With extreme light compensation compression and tension operated by ball cage.



SET TYPE BT-WF
SHANK WITH 7 PCS/SET OVERLOAD CLUTCH
TAPPING COLLET DIN, ISO & JIS SYSTEMS:
PLEASE SEE PAGE 121.

Collets Size	
TC-312	M3, M4, M5, M6, M8, M10, M12
TC-820	M8, M10, M12, M14, M16, M18, M20

Please inform the collet size when ordering.
Please use following page as reference for collet size.

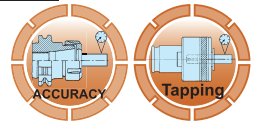

TAPPING CHUCKS

SETS

ORDER NO.	Shank Size	Thread Size	L	ØD1	ØD2	Length Compensation		Collets	PCS/SET	CODE NO.
						Compression	Tension			
VQT-312	BT-30-WF12	M3-M12	70	19	36	7.5	7.5	TC-312	7PCS	3404-190
VQT-320	BT-30-WF20	M8-M20	105	31	53	12.5	12.5	TC-820	7PCS	3404-191
VQT-412	BT-40-WF12	M3-M12	75	19	36	7.5	7.5	TC-312	7PCS	3404-192
VQT-420	BT-40-WF20	M8-M20	95	31	53	12.5	12.5	TC-820	7PCS	3404-193
VQT-512	BT-50-WF12	M3-M12	85	19	36	7.5	7.5	TC-312	7PCS	3404-194
VQT-520	BT-50-WF20	M8-M20	105	31	53	12.5	12.5	TC-820	7PCS	3404-195



Quick Change MT Tapping Chuck Set

With Overload Clutch

NEW



- Tension and compression feature allows taps to follow their own thread lead.
- With extreme light compensation compression and tension operated by ball cage.

SET TYPE MT-SF
SHANK WITH 7 PCS/SET OVERLOAD CLUTCH
TAPPING COLLET DIN, ISO & JIS SYSTEMS:
PLEASE SEE PAGE 121.

Collets Size	
TC-312	M3, M4, M5, M6, M8, M10, M12
TC-820	M8, M10, M12, M14, M16, M18, M20

Please inform the collet size when ordering.
Please use following page as reference for collet size.

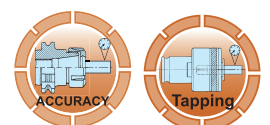

SETS

ORDER NO.	Shank Size	Thread Size	L	ØD2	Collets	PCS/SET	CODE NO.
VQT-712	MT3-SF12	M3-M12	39	32	TC-312	7PCS	3404-196
VQT-812	MT4-SF12	M3-M12	34	32	TC-312	7PCS	3404-197
VQT-720	MT3-SF20	M8-M20	59	50	TC-820	7PCS	3404-198
VQT-820	MT4-SF20	M8-M20	55	50	TC-820	7PCS	3404-199

Tapping Collet Reducer Adapter



This adapter is for transforming
This adapter allows the tapping chuck to use smaller size.
Transforming the big tapping size to smaller one.
large range type for tap M3~M24, TC312, TC820, TC1433
COST SAVING!



SIZE CONVERTER

ORDER NO.	TRANSFORMING SIZE	WIGHT	CODE NO.
TC820/TC312-AD	TC820 TO TC312	0.2	3404-461
TC1433/TC820-AD	TC1433 TO TC820	0.6	3404-462

※Every tap needs a match size tapping collet.

Adjustable Wrenches

For Tapping Collet's Torque Force Adjustment

NEW

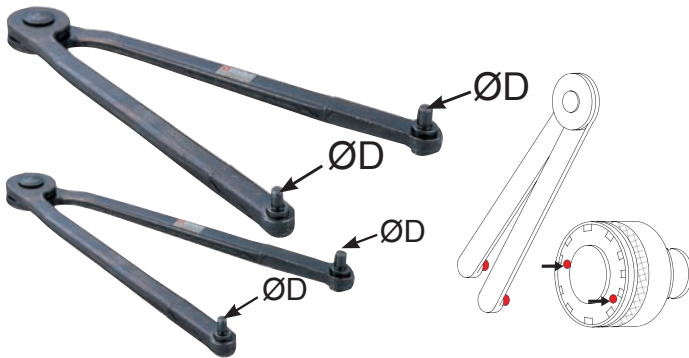

- Tool for Setting
- Time Saving

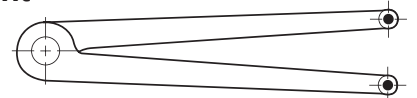

EXAMPLE



ORDER NO.	SIZE	ØD	COLLETS	WEIGHT	CODE NO.
VWR-40	7-40	2.5	TC-820	0.15 kgs	3404-150
VWR-60	11-60	4	TC1433	0.15 kgs	3404-151

Quick Change Tapping Collet TC312 8PCS/SET

ORDER NO. TC-312-DIN371-A CODE NO. 3404-175

NEW



QUICK CHANGE TAP COLLETS
(with overload safety collet)

TC-312 DIN371 8PCS/SET
(M1, M2, M3, M3.5, M4, M4.5, M8, M10)

NO.	ØD X □ SIZE SAME AS DIN371 TC312
1	M1, M1.1~M1.8
2	M2, M2.5, M2~M2.5
3	M3
4	M3.5
5	M4
6	M4.5, M5, M6
7	M8
8	M10

Quick Change Tapping Collet TC312 8PCS/SET

ORDER NO. TC-312-DIN376-B CODE NO. 3404-176

NEW



QUICK CHANGE TAP COLLETS
(with overload safety collet)

TC-312 DIN376 8PCS/SET
(M4, M5, M6, M7, M8, M10, M12 M14)

NO.	ØD X □ SIZE SAME AS DIN376 TC312
1	M4
2	M5, M4.5
3	M6
4	M7
5	M8
6	M10
7	M12
8	M14



Quick Change Tapping Collet TC820 8PCS/SET



ORDER NO. TC820-DIN 376-C

CODE NO. 3404-177

NEW

**QUICK CHANGE TAP COLLETS
(with overload safety collet)**



**TC-820 DIN376 8PCS/SET
(M8, M10, M12, M14, M16, M18, M20, M22)**

NO.	ØD X □ SIZE SAME AS DIN376 TC820
1	M8
2	M10
3	M12
4	M14
5	M16
6	M18
7	M20
8	M22, M24



Quick Change Tapping Collet TC820 4PCS/SET

ORDER NO. TC820-DIN 371-D

CODE NO. 3404-178

NEW

**QUICK CHANGE TAP COLLETS
(with overload safety collet)**



**TC-820 DIN371 4PCS/SET
(M5, M6, M8, M10)**

NO.	ØD X □ SIZE SAME AS DIN371 TC820
1	M5, M6
2	M6, M5
3	M8
4	M10



Quick Change Tapping Collet TC820 8PCS/SET

ORDER NO. TC820-ISO2283-E

CODE NO. 3404-179

NEW

**QUICK CHANGE TAP COLLETS
(with overload safety collet)**



**TC-820 ISO2283 8PCS/SET
(M8, M10, M12, M14, M16, M18, M22, M24)**

NO.	ØD X □ SIZE SAME AS ISO2283 TC820
1	M8
2	M10
3	M12
4	M14
5	M16
6	M18, M20
7	M22
8	M24

TAPPING CHUCKS