



Self Centering Vise

5 AXIS VISE



PAT.

SAME HEIGHT GUARANTEE

Features

- Reversible Jaw :Remove 4 Fixed Screw to Re-install Jaws.
- Suit for 4/5 axis CNC machine
- Repeat clamping tolerance $\pm 0.01\text{mm}$
- Material: high tension cast iron
- Slide way hardness: HRC 45°
- Inter changeable jaw: heat treatment HRC 50°
- Lock down-drawing force: keep work piece from lifting



VCV-1090

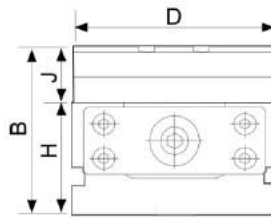
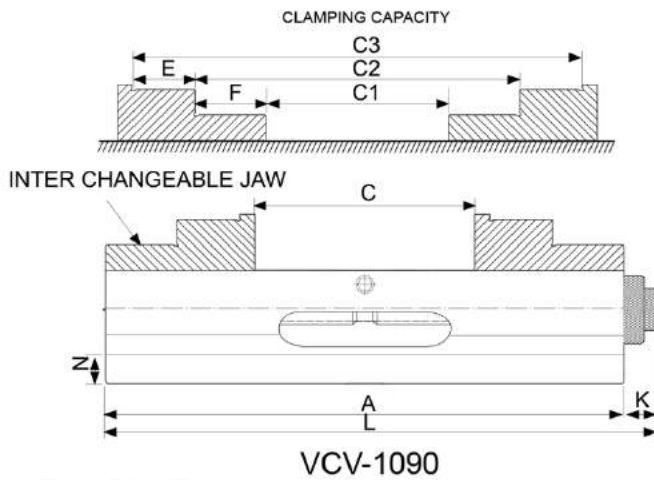

Specifications

ORDER NO.	A	B	C OPEN	Clamping Capacity			D	F	H	J	K	N	X	L	MAX. Clamp Force (kgf)	Torque For Clamp	Weight (kgs)	CODE NO.
				C1	C2	C3												
VCV-0611	170	80	106	112	45-140		61	20	55	25	15	14	14	185	300	1.8m/kgs	5	1002-107
NEW VCV-10130	240	120	132	140	62-192		101	30	80	40	16	21	20	260	400	2.6m/kgs	18.5	1002-109
VCV-1090	240	120	90	90	70-160	134-222	101	35	80	40	20	22		260	400	2.6m/kgs	17	1002-108

With Swivel Base Type

JAW CLAMPING SCREWS (EACH JAW 4 PCS)

VCV-0611S FOR CNC ROTARY TABLE

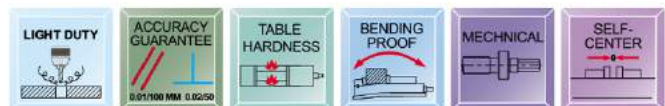

ORDER NO.	BASE SIZE	kgs	CODE NO.
VCV-0611S	Ø200 x 22 Thickness	11.1	1002-107S
VCV-10130S	Ø248 x 22 Thickness	26	1002-109S
VCV-1090S	Ø248 x 22 Thickness	27.5	1002-108S



Self Centering Vise

5 AXIS VISE



NEW

PAT.

SAME HEIGHT GUARANTEE



VCV-10130

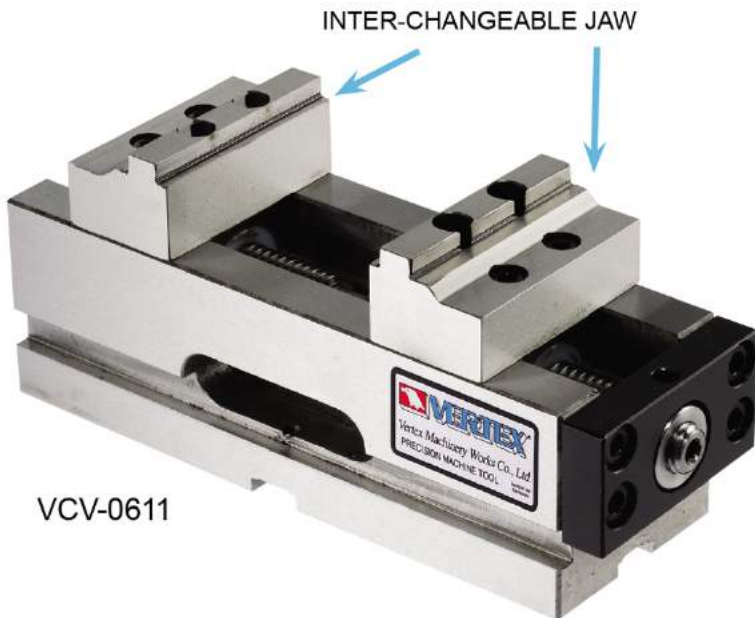

VCV-0611

Features

- Reversible Jaw :Remove 4 Fixed Screw to Re-install Jaws.
- Suit for 4/5 axis CNC machine
- Repeat clamping tolerance $\pm 0.01\text{mm}$
- Material: high tension cast iron
- Slide way hardness: HRC 45°
- Inter changeable jaw: heat treatment HRC 50°
- Lock down-drawing force: keep work piece from lifting

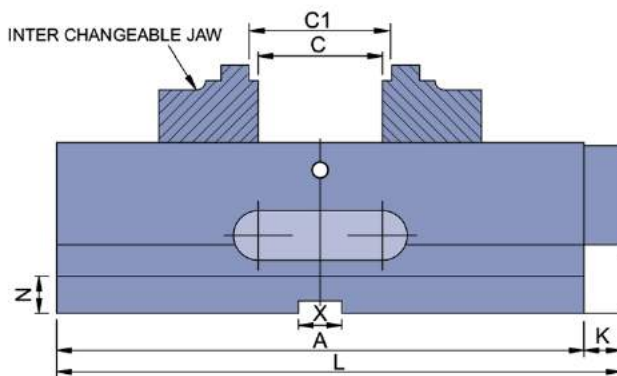
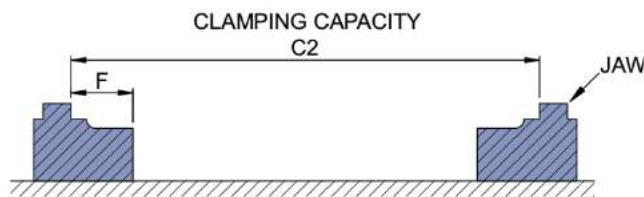

VCV-0611, VCV-10130

