



# Chamfering & Deburring For R Dual Angle Unit

**VERTEX®**



ORDER NO.VCF-500R

CODE NO. 1023-008

**NEW****S.A. ORDER NO. VCF-500R-RMC**  
Machine Unit With 2R Blade Insert**FEATURES**

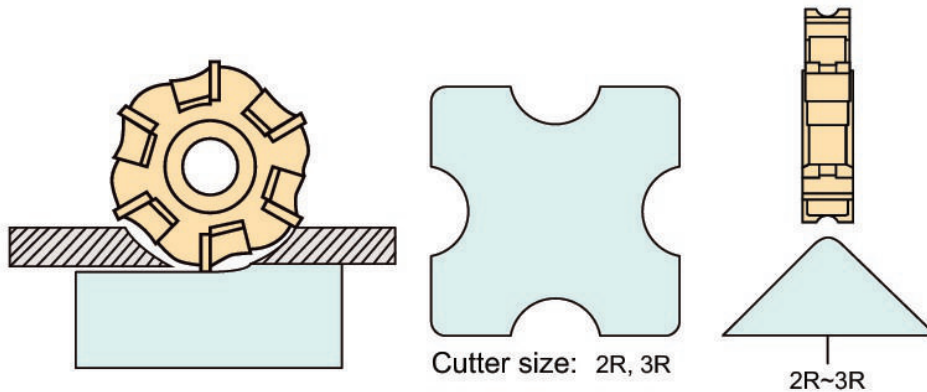
- Easy chamfering any length of steel, iron, casting iron and non-metal materials.
- Adjustable cutting point of C angle to make the full using of side knife.
- Accessories: R side mill cutter. specification form 2R, 3R.

**STANDARD ACCESSORIES**

ORDER NO.	DESCRIPTION CUTTER / INSERT	CODE NO.
VCF-500R-RMC	ROUND INSERT SIDE MILL CUTTER 	1023-039
VCF-500R-2R	2R BLADE INSERT / 10pcs 	1023-040
VCF-500R-3R	3R BLADE INSERT / 10pcs 	1023-041

**TECHNICAL DATA**

<b>Machine Size</b>	L500xW400xH320mm
<b>Voltage</b>	3Ø, 220V-400V, or 1Ø, 110V/220V ; 50Hz/60Hz
<b>Motor</b>	1HP, 3500 r.p.m. (Standard)
<b>Height of bevel</b>	2R, 3R
<b>N.W. / G.W.</b>	28kgs / 31kgs
<b>Packing</b>	55x46x32cm, 3 Cuft