

# NC Right Angle Head

High Precision

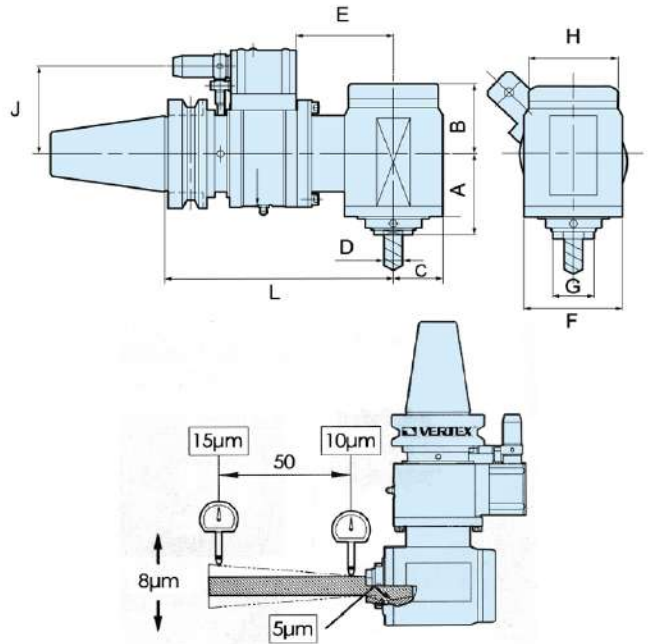

**NEW**



## Minimum interference

ORDER NO.	A	B	C	ØD	E	F	ØG	H	L	J	WEIGHT	CODE NO.
BT40-RAER32-185	78.2	63.8	44	2-20	113	88	36	80	185	65	9	3214-201
BT50-RAER32-195					113				195	80	14	3214-202
SK40-RAER32-176					113				176	65	8.8	3214-203
SK50-RAER32-173					113				173	80	13	3214-204

## VERTEX ANGLE HEAD MORE SMALLER Interference size contrast

	A	B	C
Other angle head Max. clamping diameter Ø20	Ø171	88	160
VERTEX = Angle head Max. clamping diameter Ø20	Ø156	88	140

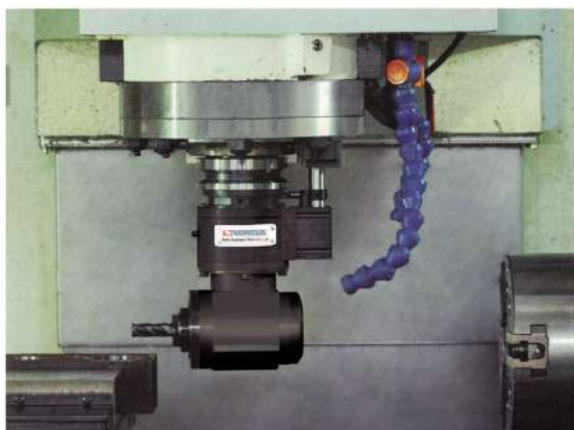
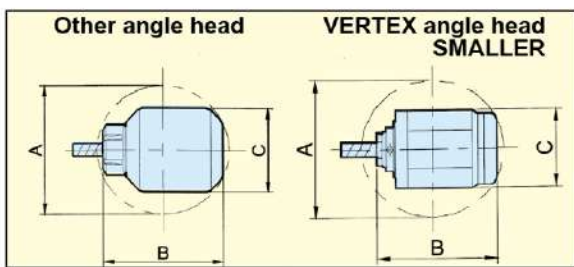

- Turn Vertical Machine To Horizontal
- Clamping range Ø 2- 20
- Max. speed : 3000 P. P. M.  
Drive ratio 1:1
- For Light Cutting-facing, Drilling, Tapping & Internal Surface Machining
- Suitable For ATC
- Use Standard BT Shank & ER32 Collets
- Built Internal Collet Chuck System Assure The High Accuracy
- High Precision & Rigid-Made Body
- Free Adjustment OF The Driving Key & Location PIN
- For Special Angle Cutting ( NC Universal Angular Head )
- Compact Design : Low Ineterference
- With Special Wrench
- Cautions : Check With VERTEX & Machine Tool Manufacturer First For The Machine Mounting Specification & Pull Stud.

### **CAUTION**

The machine tool's spindle and angle head should Rotate in opposite direction, when use, please make sure machine tool's spindle is Rotating in Reverse direction.