

Pressure

PT-5217

Liquid or Air Pressure Transmitter

The PT-5217 pressure transmitter accurately measures pressure and converts the measurement into a standard proportional 0...10 V signal.

The PT-5217 is especially adapted to measure relative and absolute pressure of liquid and gases.

The pressure transmitter consists of a piezoresistive ceramic measuring cell with a diaphragm, installed in a stainless steel housing.

Features

- Compact, rugged construction
- Negligible temperature influence on accuracy
- Low hysteresis
- High accuracy
- Direct mounting, 1,5 m cable included
- Splash proof enclosure

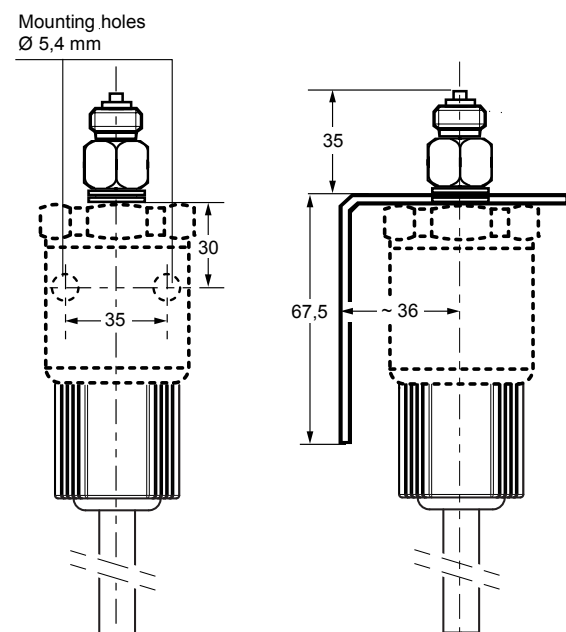
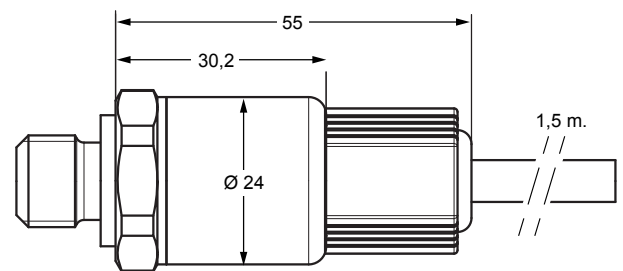

Dimensions in mm

Ordering Codes	Operating Range	Enclosure	Supply Voltage
PT-5217-7011	0...100 kPa	IP67	24 VAC +15% / -15%, 50/60 Hz or 12...33 VDC, < 7 mA
PT-5217-7101	0...1000 kPa		

Accessories (order separately)

Ordering Codes	Description
EQ-6056-7000	Mounting kit for plastic hose 4 x 6 mm
EQ-0100-7001	Mounting kit for DIN rail