

Duct sensor Humidity / Temperature

Active sensor (0...10 V) for measuring the relative or absolute humidity and temperature in duct applications. Instead of the humidity signal, the enthalpy or the dewpoint can be selected as an output signal. IP65 / NEMA 4X rated enclosure.



Type Overview

Type	Output signal active humidity	Output signal active temperature	Probe length
22DTH-11M	0...5 V, 0...10 V	0...5 V, 0...10 V	140 mm
22DTH-11Q	0...5 V, 0...10 V	0...5 V, 0...10 V	270 mm

Technical data

Electrical data	Nominal voltage	AC/DC 24 V																				
	Nominal voltage range	AC 21.6...26.4 V / DC 13.5...26.4 V																				
	Power consumption AC	0.8 VA																				
	Power consumption DC	0.4 W																				
	Electrical connection	Pluggable spring loaded terminal block max. 2.5 mm ²																				
	Cable entry	Cable gland with strain relief ø6...8 mm																				
Functional data	Application	Air																				
	Multirange	4 measuring ranges selectable																				
	Voltage output	2 x 0...5 V, 0...10 V, min. resistance 10 kΩ																				
	Output signal active note	Output 0...5/10 V with Jumper adjustable																				
Measuring data	Measured values	Relative humidity Absolute humidity Dew point Enthalpies Temperature																				
	Specification Temperature active	Sensing element technology	Polymer-based capacitive sensor with stainless steel wire mesh filter																			
		Measuring range temperature settings	Active sensor: range selectable Attention: The maximum measuring range listed does not indicate the allowable fluid temperature for the sensor. Refer to safety data for the maximum fluid temperature limits. <table border="1"> <thead> <tr> <th>Setting</th> <th>Range [°C]</th> <th>Range [°F]</th> <th>Factory setting</th> </tr> </thead> <tbody> <tr> <td>S0</td> <td>-40...60</td> <td>-40...160</td> <td></td> </tr> <tr> <td>S1</td> <td>0...50</td> <td>40...140</td> <td></td> </tr> <tr> <td>S2</td> <td>-15...35</td> <td>0...100</td> <td></td> </tr> <tr> <td>S3</td> <td>-20...80</td> <td>0...200</td> <td>✓</td> </tr> </tbody> </table>	Setting	Range [°C]	Range [°F]	Factory setting	S0	-40...60	-40...160		S1	0...50	40...140		S2	-15...35	0...100		S3	-20...80	0...200
	Setting	Range [°C]	Range [°F]	Factory setting																		
	S0	-40...60	-40...160																			
S1	0...50	40...140																				
S2	-15...35	0...100																				
S3	-20...80	0...200	✓																			
Accuracy temperature	±0.3°C @ 25°C [±0.5°F @ 77°F]																					
Long term stability	±0.05°C p.a. @ 21°C [±0.09°F p.a. @ 70°F]																					
Time constant τ (63%) in the air duct	Typical 125 s @ 3 m/s																					

Technical data

Specification Humidity	Sensing element technology	Polymer-based capacitive sensor with stainless steel wire mesh filter
	Measuring range	0...100% RH
	Measuring range absolute humidity	adjustable at the transducer: 0...50 g/m ³ (default setting) 0...80 g/m ³
	Measuring range enthalpy	0...85 kJ/kg
	Measuring range dew point	adjustable at the transducer: 0...50°C [40...140°F] (default setting) -20...80°C [0...200°F]
	Accuracy	±2% between 0...80% RH @ 25°C
	Long term stability	±0.3% RH p.a. @ 21°C @ 50% RH
	Time constant τ (63%) in the air duct	Typical 10 s @ 3 m/s
	Safety data	Protection class IEC/EN
Power source UL		Class 2 Supply
Degree of protection IEC/EN		IP65
Degree of protection NEMA/UL		NEMA 4X
EU Conformity		CE Marking
Certification IEC/EN		IEC/EN 60730-1
Quality Standard		ISO 9001
UL Approval		cULus acc. to UL60730-1A/-2-9/-2-13, CAN/CSA E60730-1/-2-9
Type of action		Type 1
Rated impulse voltage supply		0.8 kV
Pollution degree		3
Ambient humidity		Max. 95% RH, non-condensing
Ambient temperature		-35...50°C [-30...120°F]
Fluid humidity		0...100% RH, short-term condensation permitted
Fluid temperature		-40...80°C [-40...175°F]
Operating condition airflow	max. 12 m/s	
Materials	Cable gland	PA6, black
	Housing	Cover: PC, orange Bottom: PC, orange Seal: NBR70, black UV resistant

Safety notes

This device has been designed for use in stationary heating, ventilation and air-conditioning systems and must not be used outside the specified field of application. Unauthorised modifications are prohibited. The product must not be used in relation with any equipment that in case of a failure may threaten humans, animals or assets.

Ensure all power is disconnected before installing. Do not connect to live/operating equipment.

Only authorised specialists may carry out installation. All applicable legal or institutional installation regulations must be complied with during installation.

The device contains electrical and electronic components and must not be disposed of as household refuse. All locally valid regulations and requirements must be observed.

Remarks

- General remarks concerning sensors** Sensing devices with a transducer should always be operated in the middle of the measuring range to avoid deviations at the measuring end points. The ambient temperature of transducer electronics should be kept constant. The transducers must be operated at a constant supply voltage (± 0.2 V). When switching the supply voltage on/off, onsite power surges must be avoided.
- Remark: Occurring draft leads to a better carrying-off of dissipative power at the sensor. Thus temporally limited fluctuations might occur upon temperature measurement.**
- Build-up of self-heating by electrical dissipative power** Temperature sensors with electronic components always have a dissipative power which affects the temperature measurement of the ambient air. The dissipation in active temperature sensors shows a linear increase with rising operating voltage. The dissipative power should be taken into account when measuring temperature.
- In case of a fixed operating voltage (± 0.2 V), this is normally done by adding or reducing a constant offset value. As Belimo transducers work with a variable operating voltage, for reasons of production engineering only one operating voltage can be taken into consideration. Transducers 0...10 V / 4...20 mA have a standard setting at an operating voltage of DC 24 V. This means that at this voltage, the expected measuring error of the output signal will be the least. For other operating voltages, the offset error will be increased by a changing power loss of the sensor electronics.
- If a readjustment directly at the active sensor should be necessary during later operation, this can be done with the following adjustment methods.
- For sensors with NFC or dongle with the corresponding Belimo app
 - For sensors with a trimming potentiometer on the sensor board
 - For bus sensors via bus interface with a corresponding software variable
- Application notice for humidity sensors** The humidity sensor is extremely sensitive. Touching the sensor element or exposing it to aggressive substances like chlorine, ozone, ammonia, hydrogen peroxide or ethanol (i.e. as a cleaning agent) may affect the measurement accuracy.
- Long term operation outside the recommended conditions (5...60°C and 20...80% RH) can result in a temporary offset. After returning into the recommended range, this effect disappears.

Parts included

Description	Type
Mounting flange for duct sensor 19.5 mm, up to max. 120°C [248°F], Plastic	A-22D-A35

Accessories

Optional accessories	Description	Type
	Replacement filter sensor probe tip, wire mesh, Stainless steel	A-22D-A06
	Connection adapter flex conduit, M20x1.5, for cable gland 1x 6 mm, Multipack 10 pcs.	A-22G-A01.1

Wiring diagram

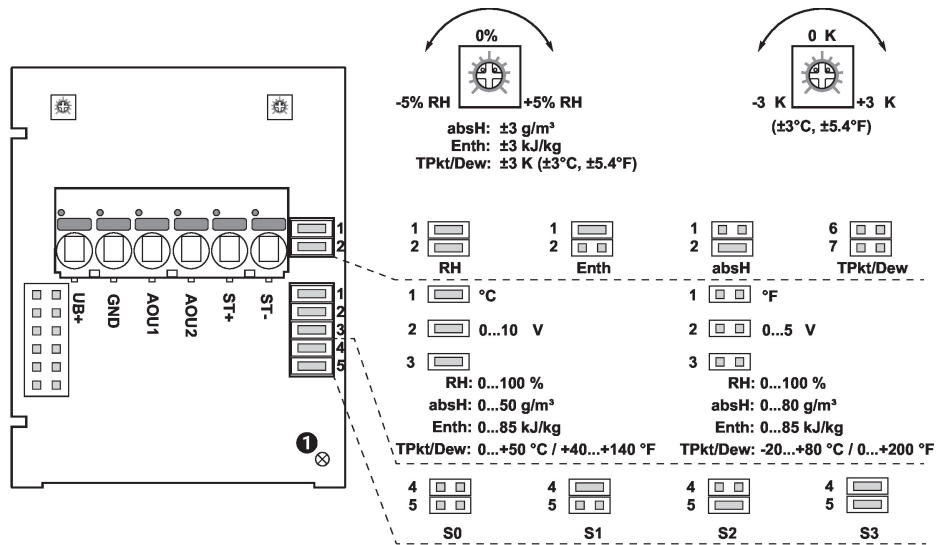

2 x 0...5/10 V

- ① Status LED
- RH Relative humidity
- absH Absolute humidity
- Enth Enthalpy
- TPkt/Dew Dew point
- (Measured value available on output AOU1)

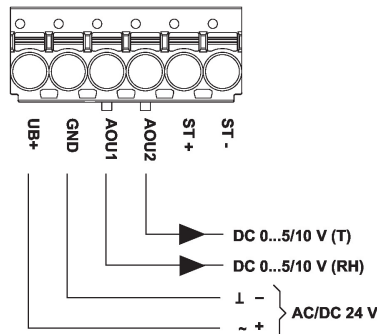

The following measuring ranges can be adjusted through the jumper settings:

Setting	Range [°C]	Range [°F]	Factory setting
S0	-40...60	-40...160	
S1	0...50	40...140	
S2	-15...35	0...100	
S3	-20...80	0...200	✓

Dimensions

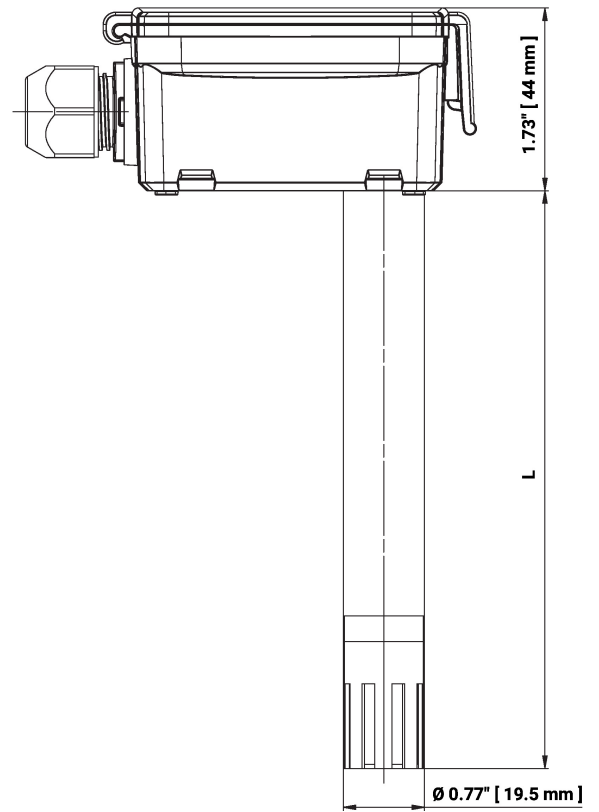
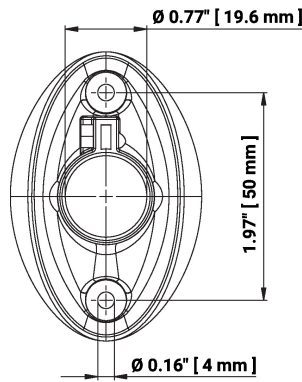
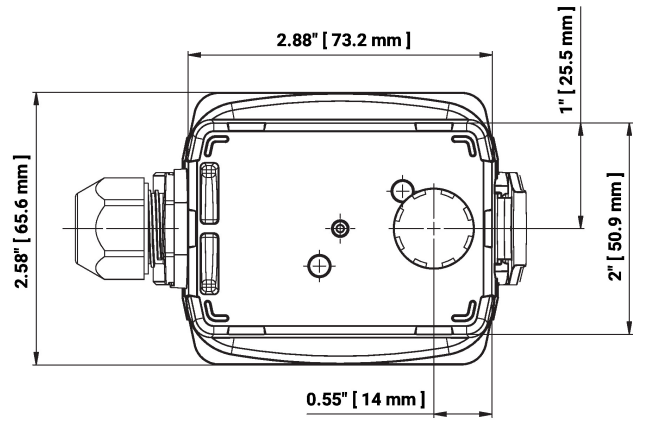

L = Probe length

Type	Probe length	Weight
22DTH-11M	140 mm	0.14 kg
22DTH-11Q	270 mm	0.20 kg

Further documentation

- Installation instructions