

6 5 4 3 2 1

D

D

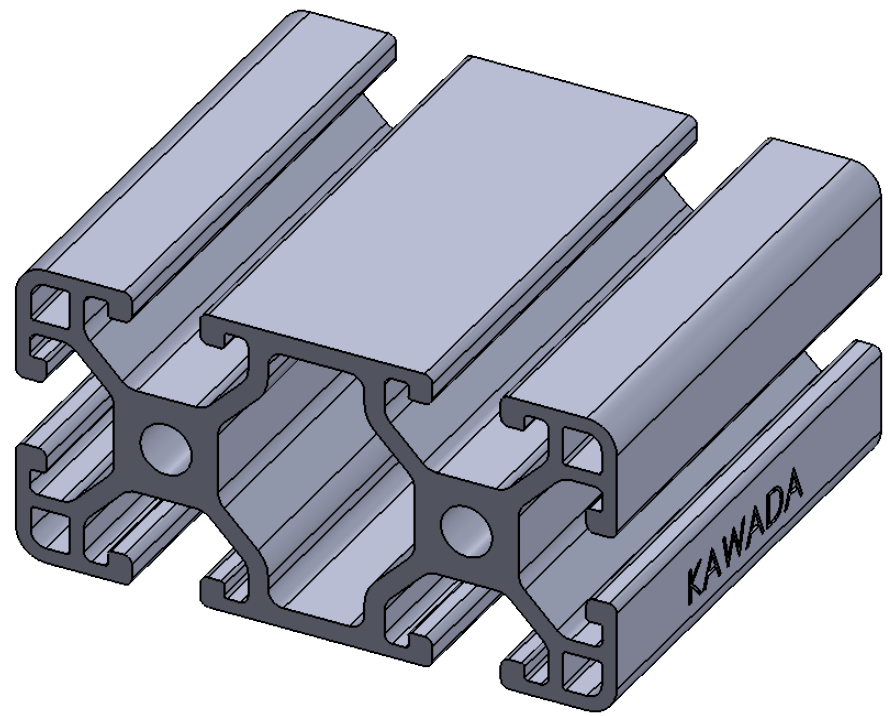
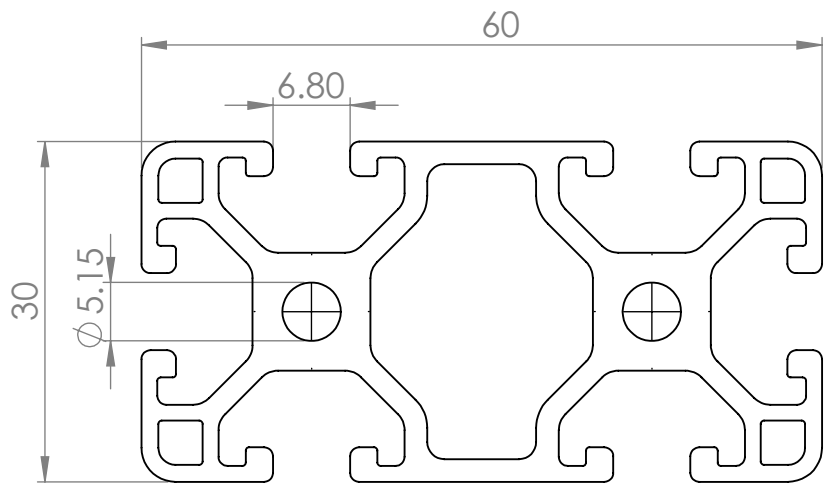

C

C

B

B

Model	Material	Treatment	Drawn by
AL-P6-30-60	AL-6063-T5	10 microns NA	KAWADA

A

A

Kawada かやだ
Japan
Linear Bearing, Shaft

No.7, Jalan Makmur 3, Taman Perindustrian Cemerlang, 81800 Ulu Tiram, Johor Bahru, Malaysia
Email: sales@kawada.com.my
Website: kawada.com.my

6 5 4 3 2 1