



# LED T8 Tube Retrofit (ALP)



## Application

- Widely used Indoor Lighting, Office, Walk Way, Corridor Lighting, Parking Area, Factory & Mall.

## Product Description

- Customized Aluminium & Polycarbonates frosted housing, resist high impact, soft lighting, no glare.
  - Good heat dissipation and Long lifespan.
  - Elegant appearance, fashionable, easy installation.
  - Rational construction & better structural strength, ensure no damage during transportation.
- 
- ✓ Products compliance with international safety standards with protective circuit.
  - ✓ Certified CE, EMI, EMC, LVD, RoHS.
  - ✓ High insulation, No interference from the power grid environment and safety.
  - ✓ Pass 2KV anti surge test ( IEC500V), no longer subject to the unstable power grid and light strike.
  - ✓ Special encapsulating LED chip and thermal dispatching design, low lumen decay, colour temperature consistent.
- 
- ❖ High CRI  $\geq 80$  Ra
  - ❖ High Lumens output  $\geq 115$  Lm/W.
  - ❖ THD  $< 20\%$
  - ❖ High Efficiency  $\geq 90\%$
  - ❖ High Power Factor  $\geq 0.90$ .
  - ❖ Long Lifespan  $\geq 30000$  hours.
  - ❖ Wide beam angle  $160^\circ$
  - ❖ Green environmental protection, lead-free material meet the requirements of ROHS.

# Model & Specification

Model	LED-T8G13-P09-ALP	LED-T8G13-P18-ALP
Input Voltage	AC 170 ~ 265V	AC 170 ~ 265V
Frequency	50/60Hz	50/60Hz
Operating Current	0.04A	0.09A
Power Rating	9 ± 1W	18 ± 2W
Power Factor	> 0.90	> 0.90
CRI	> 80 Ra	> 80 Ra
Operating Temp	- 20° + 50°	- 20° + 50°
Luminous Flux	≥ 1050 Lm	≥ 2100 Lm
Color	6500K	6500K
Lamp Socket	G13	G13
Length	600mm	1200mm
Lighting Source	SMD 2835 LED	SMD 2835 LED
Cover option	Frost	Frost
Beam Angel	160°	160°
Material	AL / PC	AL / PC
Life span	> 30000Hrs	> 30000Hrs
Energy Saving	≥ 60%	≥ 60%
Certification	CE EMC, LVD, RoHS	CE EMC, LVD, RoHS
Qty / Carton	25pcs	25pcs

## Installation Guide

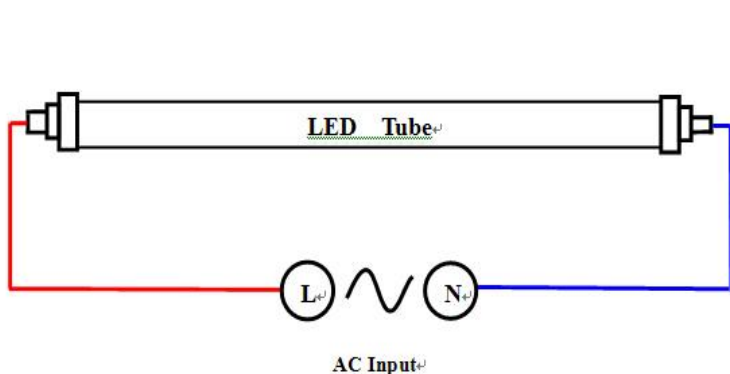

### Remarks:

Detail and specification are current at the time of publication but may be changed without prior notice