

UFO LED HIGH BAY



Model No: SLX-SR-HB

100W/150W/200W

Features

- 1、 LED lamp beads, high transmittance, uniform and soft light effect.
- 2、 Protection grade IP65,suitable for indoor humid environment and outdoor rain.
- 3、 This product is suitable for factory buildings, stations, large warehouses, toll stations,gas-stations, exhibition halls, gymnasiums,industrial and mining areas and other semi outdoor and indoor occasions with higher requirements.

Product size

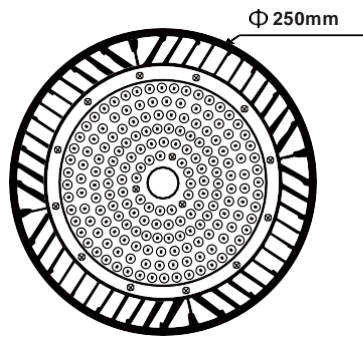

100W

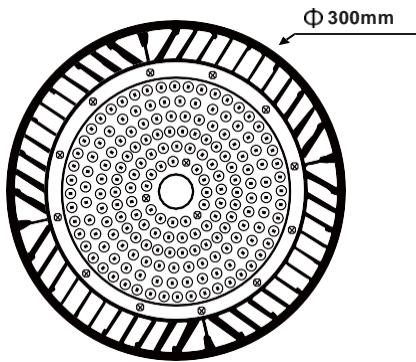
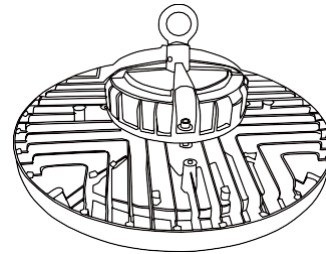

150W

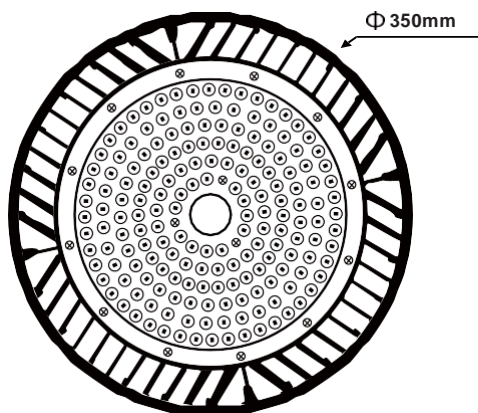
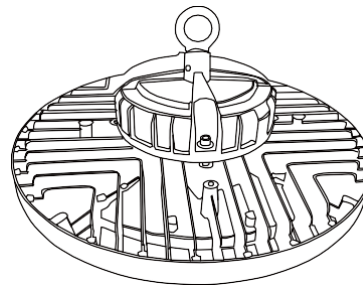

200W

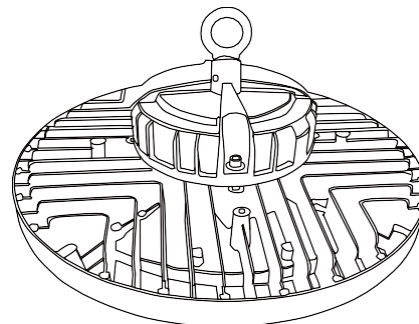

Product parameter

Model NO	Power (W)	Light Source	Product Size	CCT (K)	Voltage	Lumen (lm/w)	Power Factor	Surging	CRI	IP Grade	Beam Angle
SLX-SR-HB100	100W	3030 Φ	250mm	6500K	AC85-265V	130LM/W	> 0.9	4KV	> 70	IP65	90°
SLX-SR-HB150	150W	3030 Φ	300mm	6500K	AC85-265V	130LM/W	> 0.9	4KV	> 70	IP65	90°
SLX-SR-HB200	200W	3030 Φ	350mm	6500K	AC85-265V	130LM/W	> 0.9	4KV	> 70	IP65	90°

Light distribution diagram

