

# HUAHENG

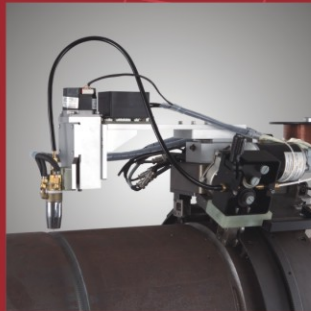
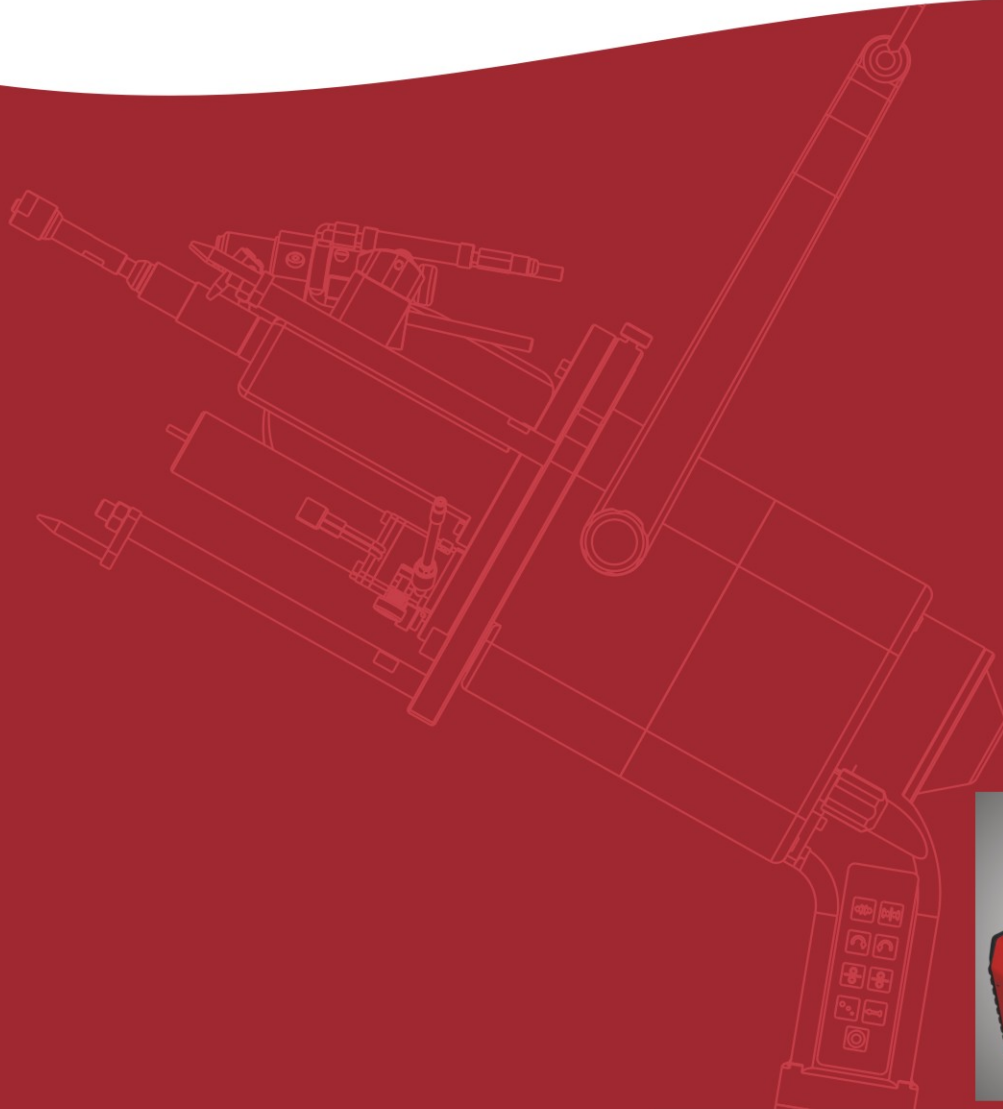

## ORBITAL Welding System

HUAHENG WELDING CO., LTD.

# TP8

## Tube to Tube-sheet Welding Head

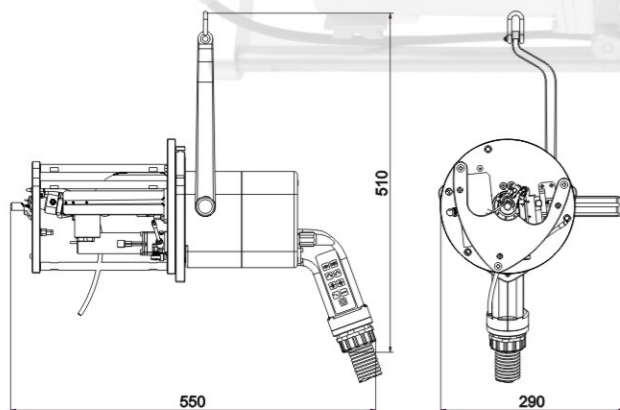

### Brief Introduction

This welding head is special designed TIG welding head for small tube to tube-sheet, suitable for carbon steel, stainless steel, mainly for protrusion tube, flush tube and retract tube connection without wire feeding or with wire feeding. The standard one is small torch; it could weld high protection requirement material such as Titanium alloy with tow cover.

Support equipment: i-Arc400 Programmable Orbital Welding Power Source.

Application: chemical, food, medicine, heat exchanger, power plant, military, nuclear and so on.

### Technical Specification

Material	Carbon steel, stainless steel, titanium alloy (with cover)
Tube OD (mm)	Φ8 - Φ32 (3/8" - 1 1/4")
Connection	Retract tube, protrusion tube, flush tube
Rotation speed (rpm)	0.37 - 7.39
Arc adjusting distance (mm)	18
Max wire feeding speed (mm)	1800
Wire Diameter (mm)	Φ0.8
Protective gas	Ar
Cooling	Water
Cooling flow (ml/min)	≥600
Duty cycle	300A 60%
Weight (kg)	11 (no cable)
Dimension (mm)	550 x 290 x 510

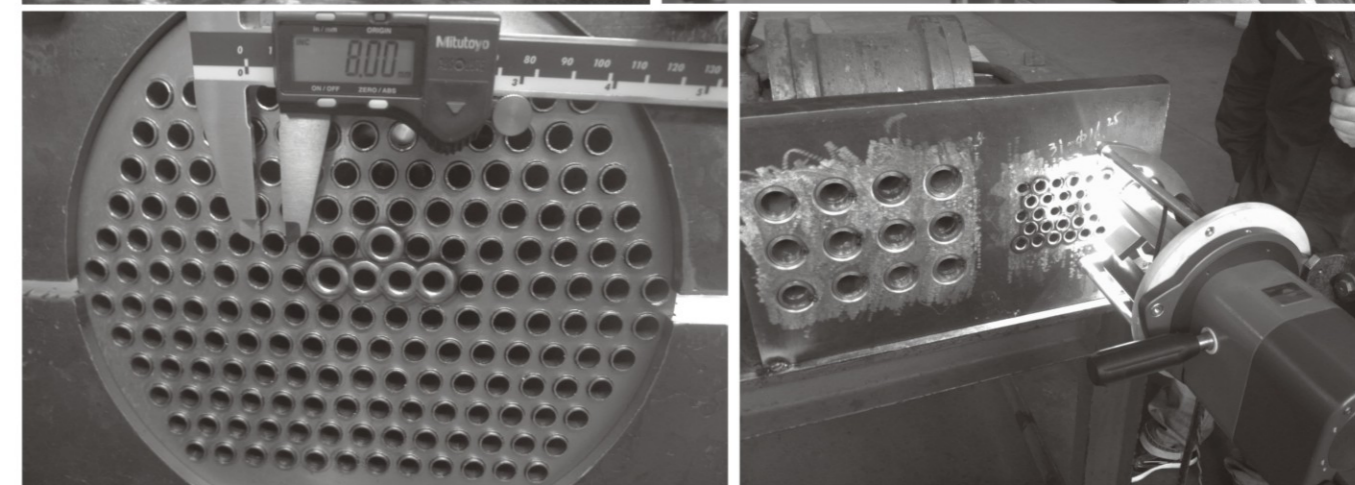
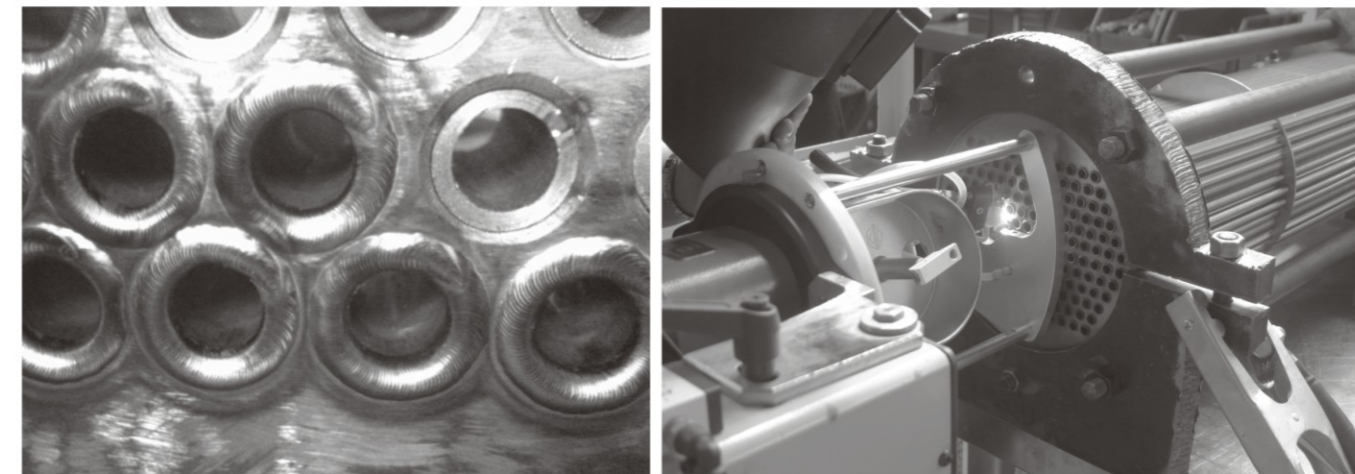

### Features

- High-precision localizer, fast and accurate, suitable for small heat exchanger;
- Auto AVC controlling on or off for manually adjusting;
- Water cooling TIG welding head, convenient to change or adjust tungsten;
- Integrated wire feeding, 1.0KG wire plate;
- No wire twist design and special wire feeding design to achieved complex single-layer welding or multi-layer welding requirements;
- Buttons on handle, convenient to operate.

# HUAHENG

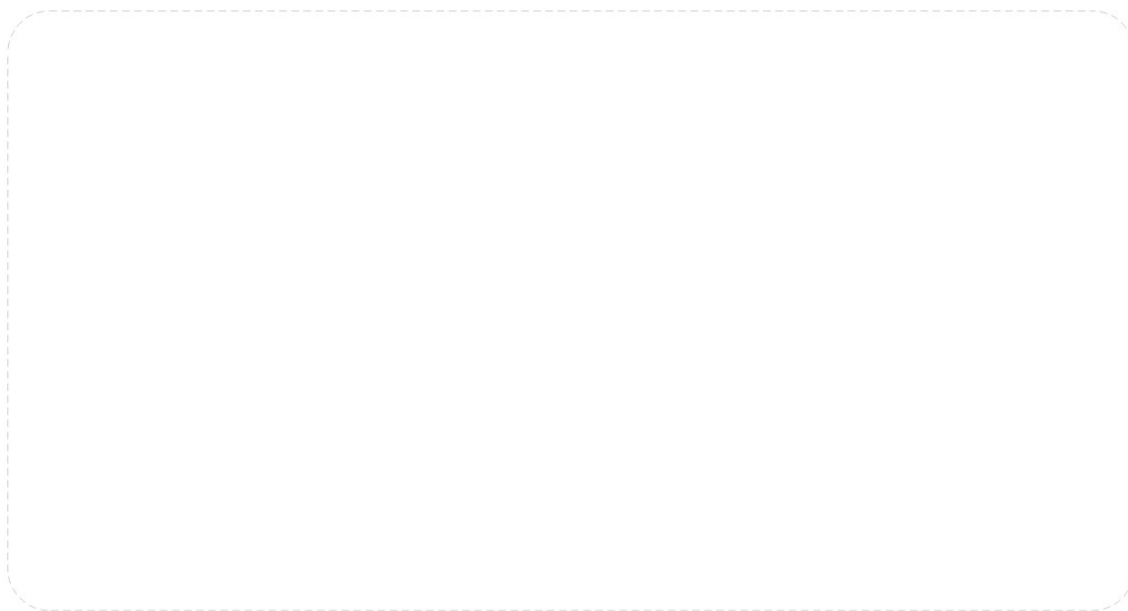

**HUAHENG**  
HUAHENG WELDING CO., LTD.

Add : No.1588 Boshi Road,Kunshan,Jiangsu,P.R.China. PC: 215347  
Tel : +86(0)512-81866666 Fax : +86(0)512-57328188  
[www.huahengweld.com](http://www.huahengweld.com) E-mail : [info@huahengweld.com](mailto:info@huahengweld.com)