

Model 812

cylinder horizontal

Model no.	Holding force max.		clamping force 5 bar	
	inner [N]	outer [N]	inner [N]	outer [N]
812	450	300	400	270

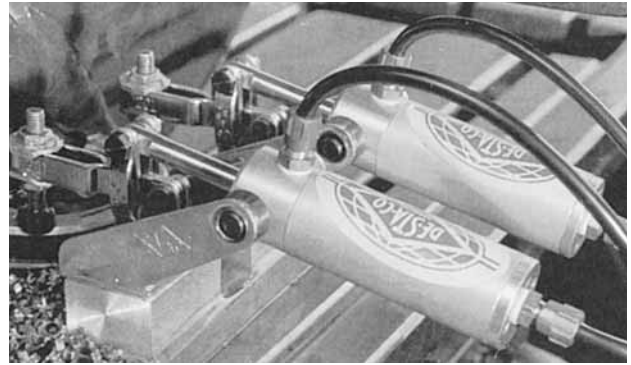

Mini power clamp model 812 on a sawing fixture

Standard equipment

- 1 adjustment spindle M5, part no. 213208-M
- 2 flange washers, part no. 102111

Series 802

NEW

Model no.	Holding force max.		clamping force 5 bar	
	inner [N]	outer [N]	inner [N]	outer [N]
802-U	1.100	600	1.000	500
802-UE	1.100	600	1.000	500

Standard equipment

- 1 adjustment spindle M6, part no. 202208-M
- 2 flange washers, part no. 215105-M



Model 802-UE



Model 802-U

Optional equipment for model 802-UE

- Sensor for T-slot



SME-8F-DE
(includes cable)



SME-8F-DE-S
(includes plug)

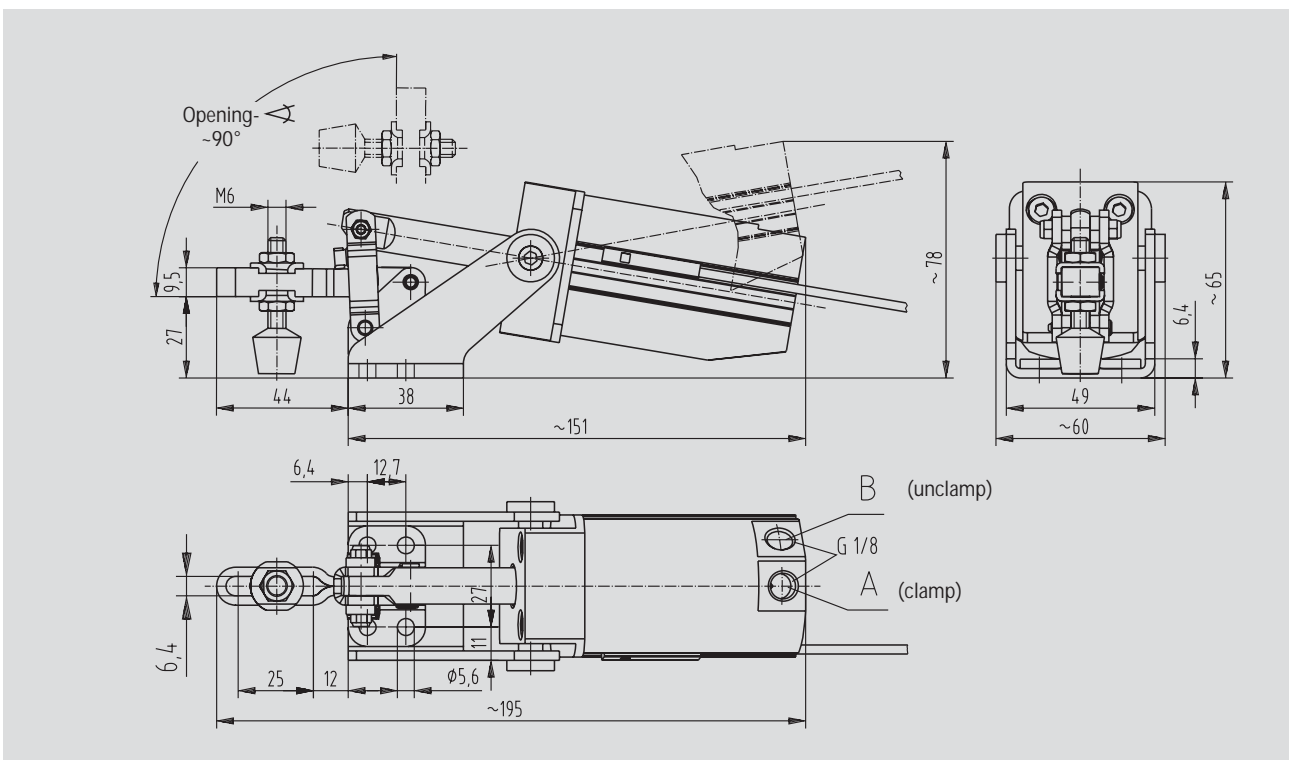
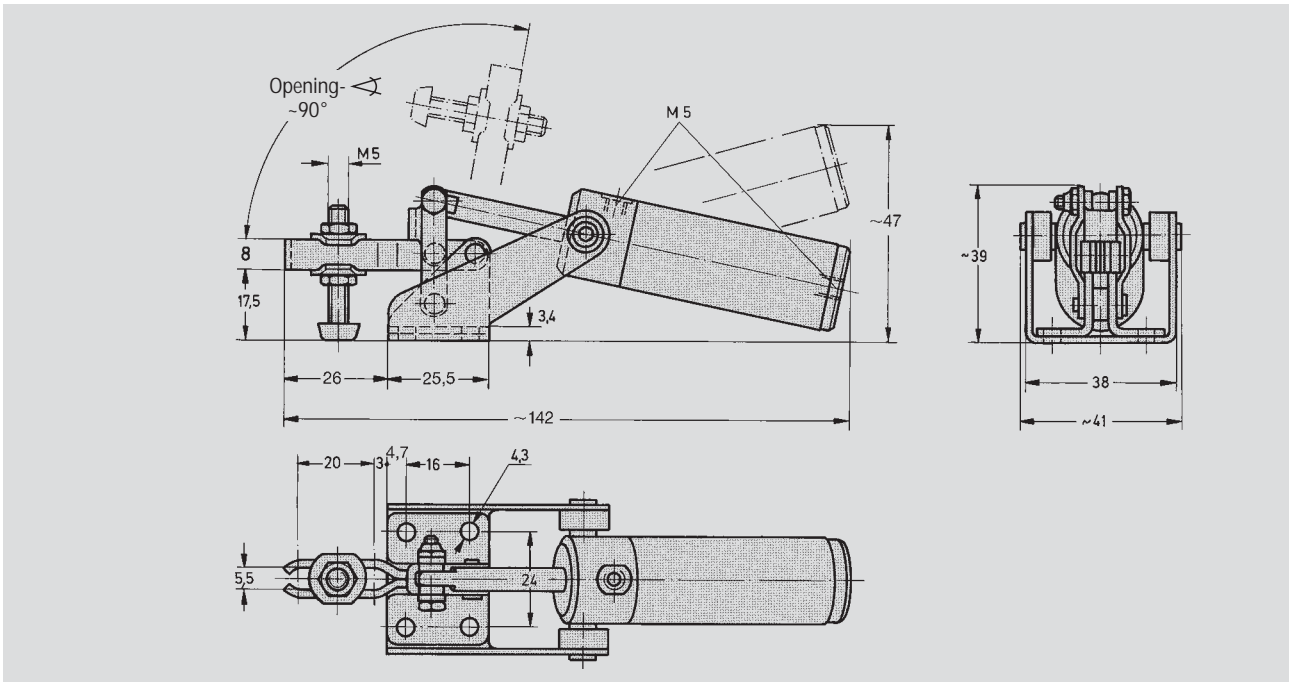

Model no.	operating pressure max. [bar]	air consumption per double stroke [dm ³]	connection	weight ~ [kg]
812	4,5	0,1 (bei 4 bar)	M5	0,25
802-U	6	0,3 (bei 5 bar)	G1/8	0,5
802-UE	6	0,3 (bei 5 bar)	G1/8	0,5