

Series 602, 604, 624 Product Overview

Features:

- Versatile and compact straight line action clamps
- Threaded body for through hole mounting
- **-SS** models are stainless steel

Applications:

- Assembly
- Checking fixtures
- Welding fixtures
- Tensioning devices

Also Available:

See page 8.1 for accessories

- ▲ 602
- ▲ 602-SS
- 602-MM
- 602-MMSS



- ▲ 604
- ▲ 604-SS
- 604-MM
- 604-MMSS ⓘ



- ▲ 624
- 624-SS
- 624-MM



Series 602, 604, 624 Technical Information, Holding Capacities, Standard Clamp Dimensions

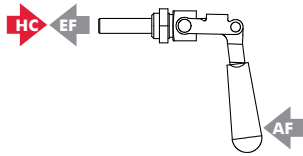

Model	Max. Holding Capacity	Weight	EF:AF (pushing/pulling)	Plunger Travel	(M) Plunger Thread	Spindle (Recommended)	Mounting Nut (Supplied)
▲ 602					1/4-20	205203	602105
▲ 602-SS	[200 lbf] 900 N	[0.12lb] 0,05kg	31:1/28:1	[0.75] 19	M6	202943	602905
● 602-MM						205203-M	602105-M
■ 602-MMSS						202943-M	602905-M
▲ 604	[300 lbf] 1330 N				5/16-18	207203	606104
▲ 604-SS	[400 lbf] 1780 N	[0.44lb] 0,20kg	45:1/26:1	[1.50] 38		--	606904
● 604-MM	[300 lbf] 1330 N				M8	207943	606104-M
● 604-MMSS ⓘ	[400 lbf] 1780 N					207943-M (included)	606904-M
▲ 624					3/8-16	210203	624105
● 624-SS	[700 lbf] 3110 N	[1.63lb] 0,74kg	49:1/21:1	[2.63] 66		237943 (included)	624905
● 624-MM					M10	210203-M	624105-M

ⓘ This item is available upon request **HC** = Holding Capacity, **EF** = Exerting Force, **AF** = Applied Force
 Preferred Market: ▲ NA/SA ■ Europe ● Global



Series 602, 604, 624 Standard Clamp Dimensions 602/604/624/-SS/-MM/-MMSS

- ▲ 602
- ▲ 602-SS
- 602-MM
- 602-MMSS



- ▲ 604
- ▲ 604-SS
- 604-MM
- 604-MMSS



- ▲ 624
- 624-SS
- 624-MM

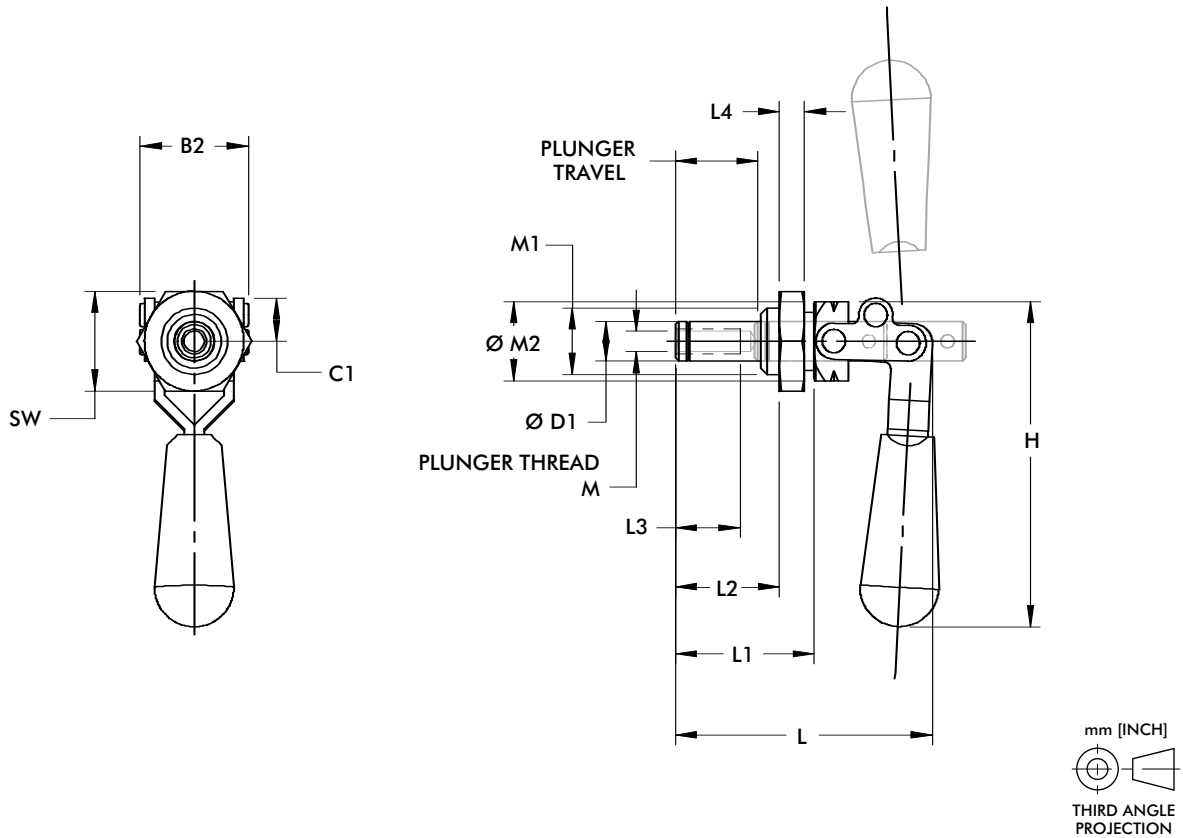

Model no.	B2	C1	ØD1	H	L	L1	L2	L3	L4	M1	M2	SW
602										5/8-18		0.44 in
602-SS		[0.88]	[0.39]	[3.13]	[2.62]	[1.31]	[0.97]	[0.63]			[0.75]	
602-MM		22	10	80	67	33	25	16		M16x1.5	19	24mm
602-MMSS	[1.03]											
604	26											
604-SS		[0.50]	[0.44]	[4.16]	[4.95]	[2.18]	[0.63]	[1.00]	[0.25]	3/4-16	[0.88]	1.00 in
604-MM		13	11	106	126	55	16	25	6		22	
604-MMSS										M20x1.5		30mm
624												
624-SS	[1.81]	[0.75]	[0.62]	[5.60]	[6.68]	[3.62]	[3.24]	[1.25]		1-14	[1.25]	1.50 in
624-MM	46	19	16	142	170	92	82	32		M27x2	32	41mm

Dimensions shown mm [inch]