

# INSTRUCTION MANUAL

OxyTechw<sup>2</sup> GAL Dissolved Oxygen Sensor



\*\* This page is intentionally left blank \*\*

## Table of Contents

1 Foreword.....	5
2 Introduction.....	6
2.1 Manual Conventions.....	6
2.2 WaterWatch <sup>2</sup> Trademark.....	6
2.3 Scope of Manual.....	6
2.4 External Sensors.....	6
3 Safety Precautions.....	7
3.1 General.....	7
3.2 Electrical installation.....	7
3.3 Operating.....	7
3.4 Service and Maintenance.....	7
3.5 End of Life Disposal.....	8
4 OxyTechw <sup>2</sup> GAL Sensor.....	9
4.1 Sensor Overview.....	9
4.2 Storage.....	9
5 Mechanical Installation.....	10
5.1 Mounting Options.....	10
5.2 Mounting Shaft.....	10
5.3 Handrail and Wall Brackets.....	11
5.4 Customer Supplied Brackets.....	11
6 Electrical Installation.....	12
6.1 Electrical Installation.....	12
6.2 Sensor Connections.....	12
6.3 Extending Sensor Cables.....	13
7 Sensor Configuration.....	14
7.1 Sensor Config.....	14
7.2 Sensor Status.....	14
7.3 Add Sensor.....	14
7.4 S:0x OxyTechw <sup>2</sup> GAL.....	14
7.4.1 S:0x Info.....	15
7.4.2 S:0x Remove.....	15
7.4.3 S:0x Modbus Address.....	15
8 Measurement Configuration.....	16
8.1 Measurement Config.....	16
8.2 Measurement Status.....	16
8.3 Add Measurement.....	16
8.4 M:0x – Measurement Channel.....	17
8.4.1 M:0x Info.....	17
8.4.2 M:0x Title.....	17

8.4.3 M:0x Set Cal (100.0 %SAT) or M:0x Set Cal (25.0 °C).....	17
8.4.4 M:0x Averaging.....	17
8.4.5 M:0x Remove.....	17
8.4.6 M:0x Display Position.....	17
8.4.7 M:0x Restore Defaults.....	17
8.4.8 M:0x Set Pressure.....	18
8.4.9 M:0x Set Salinity.....	18
9 Calibration and Testing.....	19
9.1 Temperature.....	19
9.1.1 Overview.....	19
9.1.2 Calibrate Temperature.....	19
9.2 OxyTechw <sup>2</sup> GAL.....	20
9.2.1 Zero Calibration (Service Mode Only).....	20
9.2.2 Zero Checking.....	21
9.2.3 SPAN Calibration.....	21
10 Maintenance.....	22
10.1 General cleaning.....	22
10.2 Inspection.....	22
10.3 OxyTechw <sup>2</sup> GAL Refurbishment.....	22
11 Spares.....	24
12 Technical Support.....	25
12.1 Returning Equipment for Repair.....	25
13 Technical Specification – OxyTechw <sup>2</sup> GAL.....	26
13.1 Physical.....	26
13.2 Electrical.....	26
13.3 Measurement.....	26
13.4 Mounting Options.....	26



## 1 Foreword

The OxyTechw<sup>2</sup> Sensor has been specifically designed for use with the 7300w<sup>2</sup> Monitor.

The OxyTechw<sup>2</sup> GAL Sensor has been designed to provide highly reliable Dissolved Oxygen measurements and employs the traditional galvanic principle. The rugged 100 micron, HDPE membrane has been selected to provide exceptional resistance to damage. This, combined with Oxyguard's unique electrolyte and anode material provides long term stability of 3 years and longer without the need for sensor refurbishment or membrane replacement.

For installations in activated sludge plants (ASP's), we recommend that the sensor is installed using our specially designed mounting system, with a flexible joint in the mounting shaft. The flexible joint moves the sensor in the process, keeping the membrane clean by reducing bio-fouling without the use of a compressor and with the added benefit of allowing rags to fall away from the assembly. This motion is similar to that achieved by using a floating ball assembly, with the added advantage of placing the sensor below the surface of the liquor. This means that the sensor is below the level of the floating fats and greases that accumulate at the surface and results in the Dissolved Oxygen reading being more representative of the whole tank.

The OxyTechw<sup>2</sup> Sensor provides the reliable, accurate measurement that is required to operate activated sludge plants at the optimum Dissolved Oxygen concentration, maintaining the balance between the running costs of blowers and aerators and the need to produce high quality effluent.



*OxyTechw<sup>2</sup> GAL Sensor*

## 2 Introduction

### 2.1 Manual Conventions

All dimensions stated in this manual are in millimetres unless otherwise stated.

The manual has been written assuming the user has a basic knowledge of instrumentation and an understanding of the type of measurement being made. Training in the use of the 7300w<sup>2</sup> Monitor and sensors can be provided, please contact Partech for further information.

Icons have been used throughout this manual to draw your attention to precautions and useful notes.

They are categorised in the following way-



GENERAL NOTES – General notes of interest to the user.



GENERAL CAUTION – Used where caution is required to prevent injury, damage, corruption of data, loss of calibration or invalidation of warranty etc.



INSTALLATION NOTES – General installation notes of interest to the installer.



ELECTRICAL CAUTION – Used where there is a danger of electric shock to the installer or end user, or where caution is required to prevent damage to the instrument.



MAINTENANCE NOTES – Used to highlight recommended maintenance procedures and help with fault finding.



ENVIRONMENTAL NOTES – General notes on environmental issues, waste and disposal.

### 2.2 WaterWatch<sup>2</sup> Trademark

WaterWatchw<sup>2</sup> is the family name for the w<sup>2</sup> range of Monitors and sensors. Sensors and instruments designed for specific use with the 7300w<sup>2</sup> Monitor will be suffixed with the w<sup>2</sup> trademark.

### 2.3 Scope of Manual

This manual describes the installation, configuration, testing and operation of the OxyTechw<sup>2</sup> Sensor. Please refer to 7300w<sup>2</sup> Monitor manual for standard functions of the 7300w<sup>2</sup> Monitor.

### 2.4 External Sensors

External sensors refers to any sensors or instruments connected to the 7300w<sup>2</sup> Monitor.

### 3 Safety Precautions



#### 3.1 General

Read the safety precautions carefully.

Check the delivery of your WaterWatch<sup>2</sup> sensor for damage. Any damage should be reported to your supplier as soon as possible.

Use care when unpacking the sensor. NEVER use sharp instruments to open the packaging, as this can cause damage to the sensor or cable.

Only use accessories specifically manufactured by Partech for use with this sensor.

Read the operating instructions carefully before installing and operating this sensor.

Keep the cable connections dry and free from contamination during installation.

Keep the sensor away from high voltage cables.



#### 3.2 Electrical installation



Only suitably qualified personnel or competent person may install, operate or repair this equipment.

Please check the sensor has been terminated correctly. Incorrect termination may causes damage to the sensor or monitor.

The WaterWatch<sup>2</sup> family of sensors are designed exclusively for use with the 7300w<sup>2</sup> Monitor. DO NOT connect to other monitors.

Sensors need to be correctly addressed to the monitor before use. Please read the *Quick Start* and *Advanced Configuration* sections of this manual for full details.



#### 3.3 Operating

Because these sensors have a wide range of applications, users must acquire the appropriate knowledge to use these sensors in their specific application.

Partech are always available to provide advice and assistance in your application. Please contact Partech for further information.

These sensors must be correctly calibrated before use. Please read the *Advanced Configuration* sections of this manual for full details of calibration procedures.



#### 3.4 Service and Maintenance

Before maintenance, this equipment must be isolated or disconnected from HAZARDOUS LIVE voltages before access.

Maintenance instructions for the OxyTechw<sup>2</sup> Sensor should be carried out as specified in this instruction manual. Failure to carry out regular maintenance could invalidate the Warranty.

Services and repairs must be carried out by a Partech engineer. Partech can provide a service contract for your system. Please ask for details.



### **3.5 End of Life Disposal**

Equipment should be recycled according to local regulations.

Any calibration solutions should be disposed of as described in the Manufacture Safety Data Sheet accompanied with the calibration solution.

Partech can provide recycling and disposal of your old Partech equipment, and may also provide the same service for other manufactures equipment when replaced with Partech equipment.

Partech may provide a trade-in option for new equipment. Please contact Partech for further information.

## 4 OxyTechw<sup>2</sup> GAL Sensor

Whilst every attempt has been made to ensure that these instructions are correct, common sense and good engineering practice should always be used, as every installation can present a new set of challenges and difficulties. If you are in any doubt please contact Partech or your local distributor for further information.

### 4.1 Sensor Overview

The OxyTechw<sup>2</sup> GAL Sensors a galvanic oxygen sensor. It has an upper part with Cathode, Anode and cable, and a lower part with membrane and electrolyte. It produces a temperature compensated millivolt electrical output proportional to the oxygen partial pressure it senses. It also produces a separate temperature output for the 7300w<sup>2</sup> monitor to display.

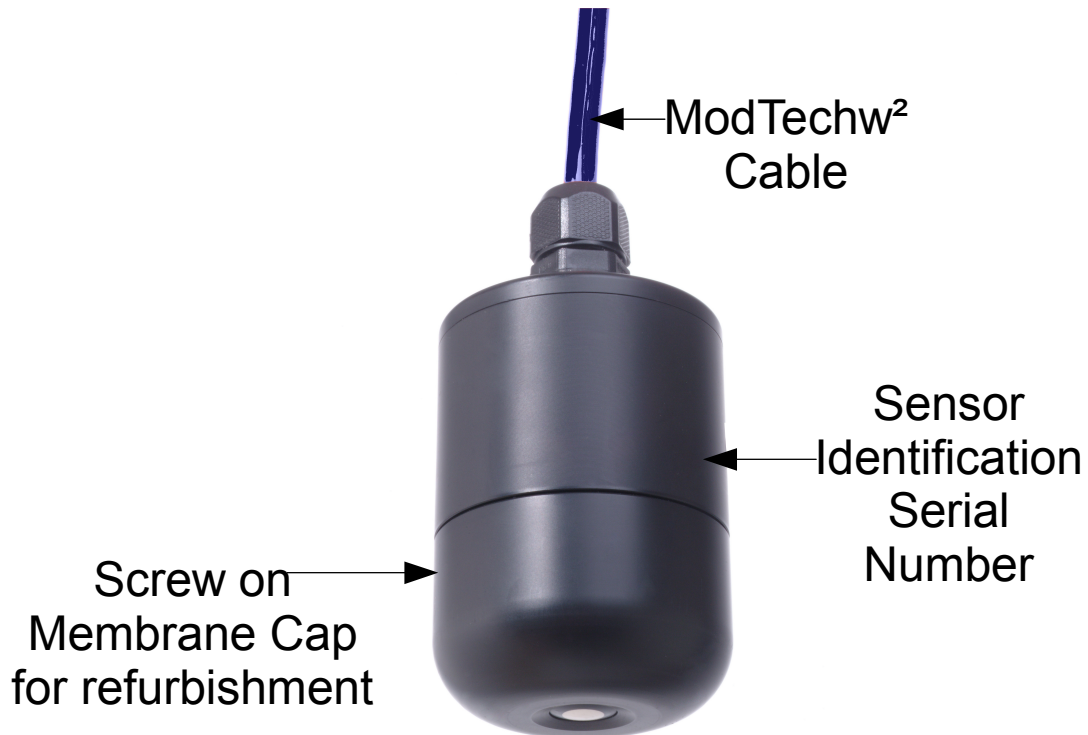

The OxyTechw<sup>2</sup> GAL Sensor is hermetically sealed, however, the bottom screw on membrane cap can be opened for electrolyte maintenance or to replace the membrane should this be required. The top cap at the cable entry end should not be opened as it contains no user serviceable parts.

The measurement stability of the OxyTechw<sup>2</sup> GAL Sensor is very high. A probe measuring in air will maintain accuracy even when subjected to a sudden 20° C temperature change. The sensitivity of a probe measuring in clean air at room temperature will remain the same for at least 3 years, therefore it is not effected by ageing as with other sensors, reducing the operating cost and the need for intensive maintenance. A well maintained sensor can have a life of 8 years without a membrane change.

### 4.2 Storage

When not in use the sensor should be stored with its yellow protective cap in place over the sensor membrane. For very long term storage, over twelve months, it is advisable to remove the electrolyte, rinse and dry the sensor and store in this dry condition.

## 5 Mechanical Installation

Reliable accurate measurement from any instrument can only be achieved by correct installation of the measuring device; in the case of the OxyTechw<sup>2</sup> Sensors, this is particularly important. If you are in any doubt contact Partech or your local distributor for advice.

Below are some points that should be considered before starting to install the sensor, or in the event an installed sensor gives unreliable measurements-

- Ensure that the sensor is immersed deeply enough into the sample.
- The sensor should be mounted in such a way as to allow easy access for calibration and maintenance. It should be possible to remove the sensor from the process without the need to shut the process down.
- The sensor must be monitoring a sample of the process that is representative of the whole process.
- To allow a single technician to calibrate and maintain the system the sensor should be placed within sight of the 7300w<sup>2</sup> Monitor. Although cable runs of up to 100 metres are possible operational problems can be caused.
- The OxyTechw<sup>2</sup> GAL Sensor should NOT be mounted with the membrane facing up.
- Where possible, angle the sensor so that it is pointing down stream, this will allow any “ragging” to be removed by the flow past the sensor.
- Do not install where there is a likelihood of freezing.

### 5.1 Mounting Options

Partech offer a range of mounting brackets for the installation of the OxyTechw<sup>2</sup> Sensor, which will allow the user to apply the sensor in a wide variety of locations. Drawings of the brackets are shown in the relevant “Optional Accessories” sections of this manual. When assessing mounting options, attention should be paid to the accessibility of the sensor for calibration and maintenance, stability of the sensor in the flow conditions present on site and to ensuring the sensor is fully submerged at all times.

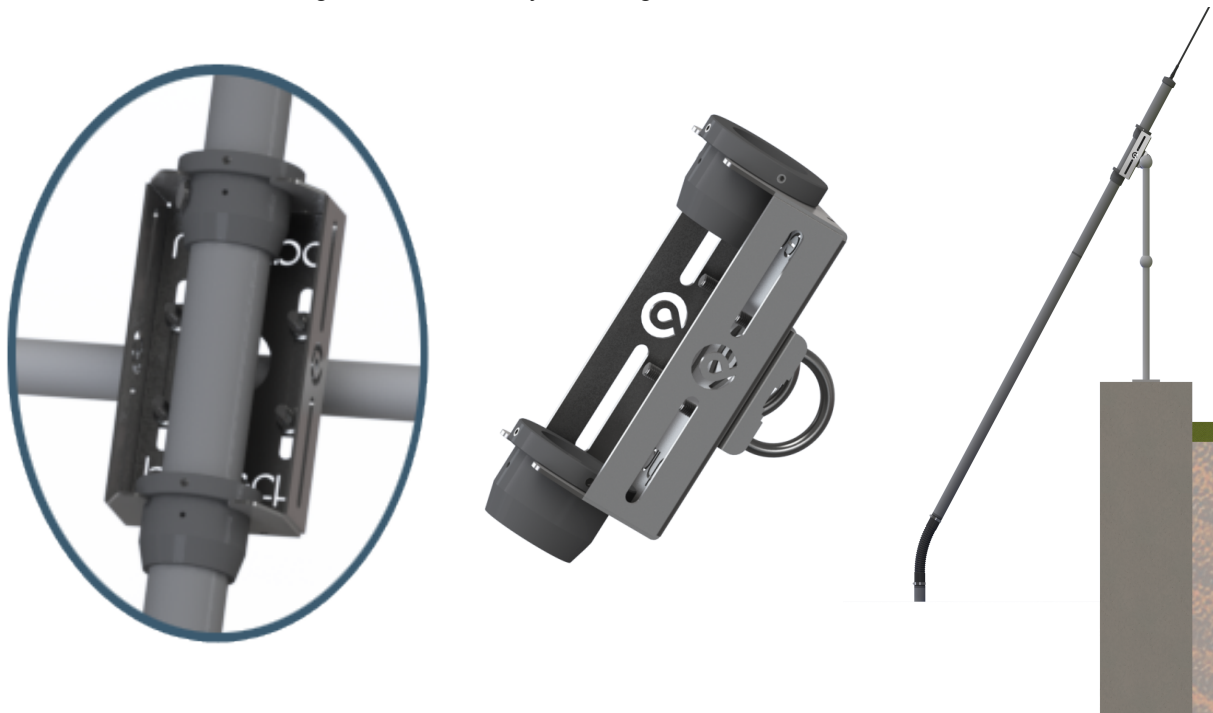

### 5.2 Mounting Shaft

An optional mounting shaft fitting can be used to allow the OxyTechw<sup>2</sup> Sensor to be fitted to a number of mounting accessories. Partech supply mounting shafts manufactured from 2” nominal bore grey ABS pipe in

0.5, 1.0, 1.5, 2, 2.5 and 3.0 metre lengths. Whilst other lengths can be provided as special orders, generally standard lengths will satisfy most requirements. It should be noted that sensors with long mounting shafts are difficult to move safely and can present problems with calibration and maintenance, shaft lengths should be kept to a minimum where possible.

### 5.3 Handrail and Wall Brackets

The mounting shafts described above need to be attached to the structure of the tank or flow channel where measurement is required. The mounting shaft sits inside the mounting bracket and is located using locking collars. To remove the mounting shaft, remove the locking thumb screw and lift the shaft from the bracket.

Care should be taken to ensure that the sensor can be reached from the walkway to allow removal for calibration and maintenance.

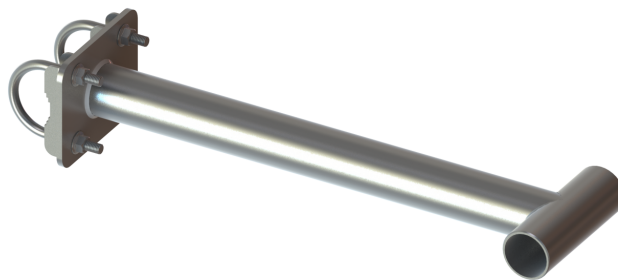
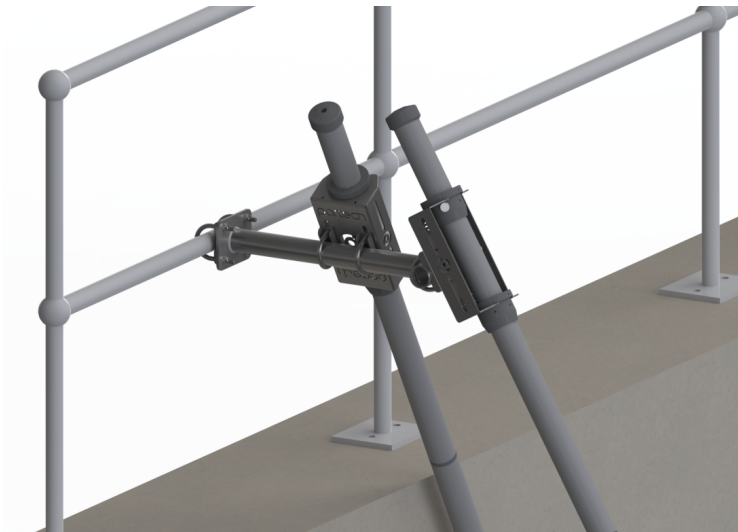

### 5.4 Customer Supplied Brackets

When creating brackets to mount the OxyTechw<sup>2</sup> Sensor, care should be taken to ensure that the following guidelines are observed:

- The bracket must be strong enough to support the sensor with minimum movement when installed into the sample.
- The sensor should be fitted by clamping around the sensor body or suspended by the cable.
- Consideration should be given to enable simple removal and replacement of the sensor for inspection, calibration and servicing to be carried out.



## 6 Electrical Installation

### 6.1 Electrical Installation



Unscrew the two cover screws on the lower panel of the 7300w<sup>2</sup> Monitor to reveal the Terminals. Each terminal strip is labelled as illustrated below. (This equipment must be isolated or disconnected from HAZARDOUS LIVE voltages before access). Refer to the 7300w<sup>2</sup> Monitor user manual for full description of all the terminals within the monitor.

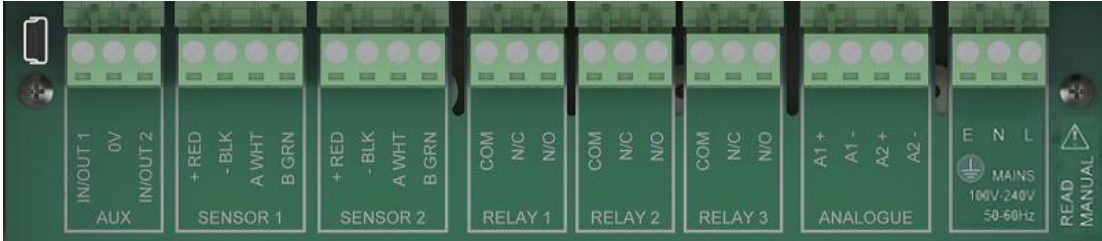

The maximum size wire that can be terminated is 2.5mm<sup>2</sup> CSA. All the connections are via removable Plug/Socket terminals. To disengage the terminal strip, simply pull down to release.

### 6.2 Sensor Connections

When routing the sensor cables, please ensure the cable is separated from any mains cables. Although the Partech w<sup>2</sup> sensors have a high resistance to interference, separation of mains and data cables is good practice and should always be followed where practical.

All sensors in the w<sup>2</sup> range communicate with the monitor using the ModTechw<sup>2</sup> Protocol. This protocol has been specifically designed to take advantage of the advanced features and diagnostics designed into the w<sup>2</sup> range of sensors.

Note- These sensors can **NOT** be used with other monitors that are not included in the w<sup>2</sup> family.

All sensors within the w<sup>2</sup> family of instruments are connected to the 7300w<sup>2</sup> Monitor using the same 4 wire configuration.

- RED and BLACK wires provide the 12VDC supply to the sensor.
- WHITE and GREEN provide data communication.

A maximum of two sensors can be directly connected to the standard 7300w<sup>2</sup> Monitor, additional sensors can be added using the optional expansion boxes available separately.

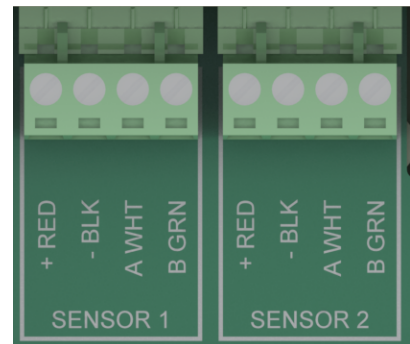

Remove the 4-way connector from the 7300w<sup>2</sup> Monitor by pulling downwards to disconnect for easy access to the connections. Connect the sensor wires as follows-

(Terminals from left to right on the 4 way connector)

- |                |   |                |
|----------------|---|----------------|
| Term 1 (Left)  | - | RED (+12V)     |
| Term 2         | - | Black (0V)     |
| Term 3         | - | White (Data A) |
| Term 4 (Right) | - | Green (Data B) |

Always connect the screen drain wire with the Black (Term 2).

Always use Bootlace ferrules when terminating the sensors to ensure a good connection to the terminals.

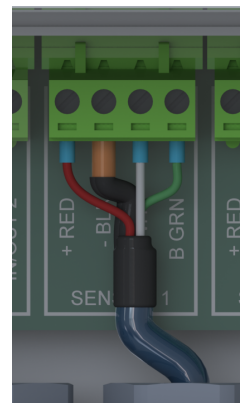



### 6.3 Extending Sensor Cables

Sensors are usually supplied with 10M cables (longer cables can be provided if requested). These cables can be extended to a maximum length of 100M. To ensure optimum performance, only use Partech ModTechw<sup>2</sup> cable for extensions. Partech can supply junction boxes to allow for cable extensions. These should be used on all installations where the cable length from the sensor to the monitor exceeds 20M (Partech Junction boxes include on-board filtering for long cable lengths). Junction boxes are also useful for local connection of sensors close to the sample point. This allows for easy replacement of sensors without the need to pull back cables to the monitor. The junction box has an on-board terminator switch that can be activated to terminate the network if the sensor is to be removed for long periods.

When joining cables, ensure the connection is fully waterproof. Any moisture ingress can effect the communication between the sensor and monitor.

ModTechw<sup>2</sup> Cable specification-

- 2 Twisted Pair - Red/Black (Power) and Green/White (Data) with Screen and Drain wire
- Cores 24AWG (0,22mm<sup>2</sup>) 7 x 0,20mm
- Outer Insulation – PUR Polyurethane Blue (RAL5003), Diameter - 5mmØ

## 7 Sensor Configuration

Before attempting to configure the sensor, please read the monitor user manual that came with your monitor. The monitor manual will introduce you to the basic set-up of the monitor, and will familiarise you with the monitor menu structure and buttons.

The monitor leaves the factory with no sensors pre-installed.

Assuming the monitor has been physically connected to a sensor, the next step is to register and configure the sensor before any measurements can be made. A single sensor may provide one or more measurements. We advise only connecting one sensor at a time. Once the first sensor has been registered, connect the second and register again. Repeat for any additional sensors.

All sensors must be registered to the monitor in this way, even if they are different types.

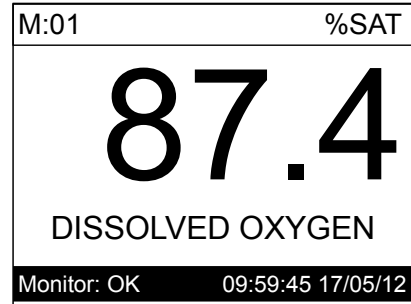

### 7.1 Sensor Config

From the MAIN MENU screen, select SENSOR CONFIG using the arrow button, and press .

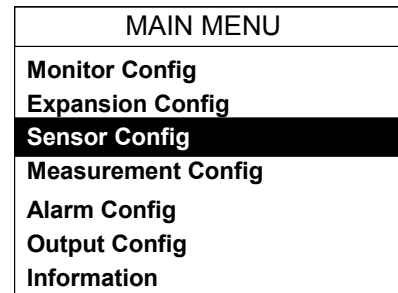

### 7.2 Sensor Status

This option allows the user to review the current status of the 8 sensor channels, these will all be set to disabled until a sensor is added.

Once a sensor has been installed the display will be updated to indicate the sensor type installed and it's status.

### 7.3 Add Sensor

- From the MAIN MENU screen, select SENSOR CONFIG by pressing , and press .
- The SENSOR MENU should be displayed. Press to highlight ADD SENSOR, and press .
- The Monitor will now search all possible addresses (0 to 240) to find any attached sensors. During the search, any sensors found will be displayed momentary before continuing with the search.
- Once the search is complete, the Monitor will display a list of sensors found. Each sensor will be automatically allocated a new address from S:01 to S:08.
- Repeat the above process to install a second, third or more sensors. A total of 8 sensors are possible (expansion box may be required to add additional sensors).
- Sensor addition is now complete.
- If a single or multiple sensors have been found the can be pressed to escape from continuing the search.

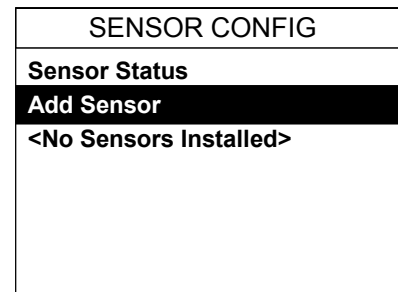

### 7.4 S:0x OxyTechw<sup>2</sup> GAL

Once the sensor has been added and registered, the monitor will provide a list of functions specific to the sensor. Press or to select the sensor and press . The CONFIG MENU will display a list of sensor functions.

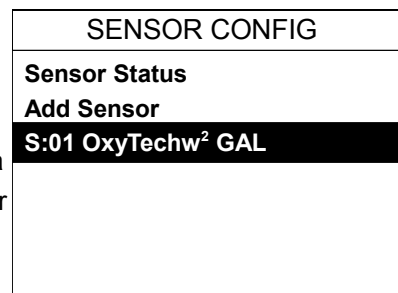

#### 7.4.1 S:0x Info

This function provides a range of diagnostic information that may be requested by Partech for fault finding.

#### 7.4.2 S:0x Remove



This allows the sensor to be removed for re-configuration of the monitor or if a sensor has been added in error. If a sensor has been replaced with a new sensors, the old sensor must be removed, and the new sensor installed. If a sensor (in a multiple configuration) is no longer required, all traces from the menus can be removed.

You will be prompted with 'Are you sure?' before the sensor is removed. Press  to accept and remove.

#### 7.4.3 S:0x Modbus Address

This option allows manual adjustment of the ModTechw<sup>2</sup> address for the sensor, under normal circumstances this should not be changed



CONFIG
<b>S:01 Info</b> <b>S:01 Remove</b> <b>S:01 Modbus Address</b>

## 8 Measurement Configuration

The monitor leaves the factory without any measurements configured. Measurements will only be available after installing the relevant sensor(s).

Once the sensor(s) have been registered with the monitor and installed, the measurements will now be available.

### 8.1 Measurement Config

From the MAIN MENU screen, select MEASUREMENT CONFIG by pressing , press . The screen shot to the left shows the default configuration after the installation of the OxyTechw<sup>2</sup> sensor on a single sensor configuration:

**M:01** = %SAT; **M:02** = mg/l; **M:03** = Temperature.

MEASUREMENT CONFIG
Measurement Status
Add Measurement
M:01 Dissolved Oxygen (S:01)
M:02 Dissolved Oxygen (S:01)
M:03 Temperature (S:01)







### 8.2 Measurement Status

This option allows the user to review the current status of the 16 measurement channels, these will all be set to disabled until a sensor is added. In the example above the first three measurement channels will be enabled.

Once a measurement has been configured the display will be updated to indicate the measurement and it's status.

### 8.3 Add Measurement

This option allows the user to add extra measurements available from the current sensor installation. i.e. One sensor may contain multiple measurements. In the screen shot above the default installation for the OxyTechw<sup>2</sup> sensor shows: M:01 Dissolved Oxygen %SAT, M:02 Dissolved Oxygen mg/l, & M:03 Temperature. There is one extra measurement that could be added to this list for the OxyTechw<sup>2</sup> sensor, and that is Dissolved Oxygen PPM. To add this measurement the following should be applied.

1. The MEASUREMENT MENU should be displayed. Press  to highlight ADD MEASUREMENT, and press .
2. All available measurements will be displayed in a list. Press  or  to select the required measurement.
3. Press  to select the measurement. Repeat the process if more measurements are required.
4. Each measurement will be allocated a measurement number from M:01 – M:16. A total of 16 measurements may be displayed.
5. Press  to return back to the display screen. Your measurement addition should now be displayed. If more than one measurements were configured, press  to cycle through the display screen to show the measurements, The screen shot on the left shows the additional measurement M:04 which is Dissolved Oxygen PPM.



MEASUREMENT CONFIG
Measurement Status
Add Measurement
M:01 Dissolved Oxygen (S:01)
M:02 Dissolved Oxygen (S:01)
M:03 Temperature (S:01)

MEASUREMENT CONFIG
Measurement Status
Add Measurement
M:01 Dissolved Oxygen (S:01)
M:02 Dissolved Oxygen (S:01)
M:03 Temperature (S:01)
M:04 Dissolved Oxygen (S:01)

The Measurement Menu will list all configured measurements in order M:01 to M:16 the list will also indicate the sensor number that is delivering the signal for the measurement. Any permutation of measurements can be configured. It is not necessary to have all four measurements enabled.

**IMPORTANT:** The primary measurement for the OxyTechw<sup>2</sup> GAL sensor is %SAT. This is the measurement that will be used for calibration purposes. The other measurements are derived from this reading plus the temperature measurement.

### 8.4 M:0x – Measurement Channel

Selecting a measurement channel will reveal a new sub-menu associated with that measurement. In **MEASUREMENT CONFIG** press  to highlight the required measurement and press .

The sub-menu is as follows:

In **M:0x CONFIG** press  to highlight the required function and press .

MEASUREMENT CONFIG
Measurement Status
Add Measurement
<b>M:01 Dissolved Oxygen (S:01)</b>
M:02 Dissolved Oxygen (S:01)
M:03 Temperature (S:01)
M:04 Dissolved Oxygen (S:01)

#### 8.4.1 M:0x Info

This option provides multiple pages of additional information and diagnostics on the measurement. This information will only be required if a problem exists with the instrument performance.

#### 8.4.2 M:0x Title

**Important Note:** This option is not available on the **Temperature** measurement.

This allows the title of the measurement to be changed from it's default, the measurement title is used in measurement mode to identify the measured value. A selection of standard terms are available along with a 'User Defined' option that can be adjusted to suit your requirements. For example this could be changed to 'DO – Lane 1'. The maximum number of characters is 20.

M:01 CONFIG
<b>M:01 Info</b>
M:01 Title
M:01 Set Cal (100.0 %SAT)
M:01 Averaging
M:01 Remove
M:01 Display Position
M:01 Restore Defaults

#### 8.4.3 M:0x Set Cal (100.0 %SAT) or M:0x Set Cal (25.0 °C)

**Important Note:** This option is only available on the **%SAT** measurement and **Temperature** measurement channels. **%SAT** is the primary measurement associated with Dissolved Oxygen. Therefore this is the only Dissolved Oxygen measurement capable of direct calibration.

The calibration of the system is covered in a separate section below.

#### 8.4.4 M:0x Averaging

**Important Note:** This option is only available on the **%SAT** measurement.

This allows the user to impose averaging on the measured value, this is used to reduce the speed of reaction to the process changes. The value can be adjusted between 0 and 6000, the higher the value the slower the reaction time.

#### 8.4.5 M:0x Remove

This allows the user to remove a measurement that has been selected in error or to allow re-configuration of the system. Please use this option with care, all user settings will be lost if the measurement is removed in error.

#### 8.4.6 M:0x Display Position

This option allows the position of the measurement to be moved. For example the Temperature measurement can be changed from M:03 to M:02 so it will appear second on the list in MEASUREMENT CONFIG menu.

#### 8.4.7 M:0x Restore Defaults

This returns all the selected measurement settings back to the factory defaults for that particular parameter. Caution should be exercised when using this feature as all user defined settings and calibration associated with that measurement will be lost and reset to their default values.

**Important Note:** This option is only available on the **%SAT & Temperature** measurement.

M:01 CONFIG
M:01 Info
M:01 Title
M:01 Set Cal (100.0 %SAT)
M:01 Averaging
M:01 Remove
M:01 Display Position
<b>M:01 Restore Defaults</b>

**8.4.8 M:0x Set Pressure**

**Important Note:** This option is only available on the **mg/l** or **PPM** measurement.

This option allows the user to set a fixed pressure value in mbar within the mg/l or PPM measurements to compensate the Dissolved Oxygen reading for changes in pressure in the environment of the sensor.

**8.4.9 M:0x Set Salinity**

**Important Note:** This option is only available on the **mg/l** or **PPM** measurement.

This option allows the user to set a fixed salinity value in ppt within the mg/l or PPM measurements to compensate the Dissolved Oxygen reading for changes in salinity in the environment of the sensor.

M:01 CONFIG
M:01 Info
M:01 Title
M:01 Remove
M:01 Display Position
<b>M:01 Set Pressure</b>
M:01 Set Salinity

## 9 Calibration and Testing

### 9.1 Temperature

#### 9.1.1 Overview

As already mentioned the OxyTech2<sup>2</sup> GAL sensor has two integral temperature measurements. The first measurement is not displayed and is used solely to compensate for temperature fluctuations in the measurement solution across the membrane. It produces a stabilised millivolt electrical output proportional to the oxygen partial pressure it senses. The other temperature measurement is transmitted back to the 7300 monitor and is used to:









- 1) Display temperature.
- 2) Compensate for changes in saturation reading due to temperature, by referencing the reading to a fixed temperature value.
- 3) Calculating the solubility of the solution in mg/l.

Once the temperature has been calibrated there should be no reason to re-calibrate as the measurement is inherently stable and will not change over time. The accuracy of the reading depends on the sensor head equilibrating with temperature. Thus the sensor element buried within the body of the sensor becomes representative of the true temperature in the surrounding environment.

The temperatures integrity can be checked at any time by comparing it with a known temperature reference after a period of temperature equilibration. If for any reason the temperature is deemed to be inaccurate or needs to be different from the settings as carried out in the factory, then the following procedure may be applied.

#### 9.1.2 Calibrate Temperature

From the 7300w<sup>2</sup> Monitor, navigate to the Calibration menu as follows:

1. Ensure that the sensor head, whether in or out of solution has been in a constant temperature environment for at least 20 minutes before commencing this operation. Ensure that the reference measurement tool, e.g. thermometer is also suitably temperature equilibrated.
2. Press  to show the "MAIN MENU".
3. Select "MEASUREMENT CONFIG" by pressing  and press .
4. Select "TEMPERATURE" by pressing  and press .
5. Select "SET CAL" by pressing  press .
6. The sensor information screen will be displayed. Press  to move on.

MEASUREMENT CONFIG
Measurement Status
Add Measurement
M:01 Dissolved Oxygen (S:01)
M:02 Dissolved Oxygen (S:01)
<b>M:03 Temperature (S:01)</b>
M:04 Dissolved Oxygen (S:01)

M:03 CONFIG
M:03 Info
<b>M:03 Set Cal (25.0 °C)</b>
M:03 Remove
M:03 Display Position
M:03 Restore Defaults

M:03 SET CAL (25.0 °C)
<b>CALIBRATE MEASUREMENT</b>
M:03 temperature
S:01 OxyTechw <sup>2</sup> GAL
SN: 400001
Last Calibrated: 01/01/1970 00:00:00
By:
Press OK to continue or MENU to Exit

- The “SET CAL” screen will be displayed. Using the arrow keys set the temperature value the same as is displayed on your temperature reference tool. Press to accept. The Calibration screen will now be displayed.

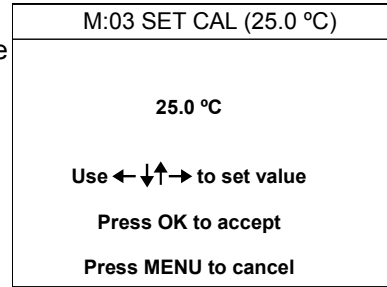

- Wait for the value to stabilise (*The digits should not be changing*), then press to accept.

The temperature calibration is now complete.

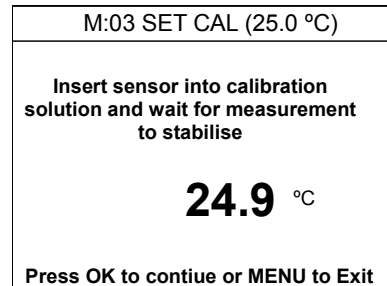

## 9.2 OxyTechw<sup>2</sup> GAL

The OxyTech<sup>2</sup> GAL sensor is very stable and will maintain its calibration for extended periods of time, the primary reason for a change in the calibration is the presence of a bio-film on the membrane. The design of the sensor means that zero point testing is not required. We recommend that calibration is carried out during commissioning and is then checked after one weeks operation. Following this calibration should be carried out after 3 months. At this time ongoing calibration frequency can be determined. This would normally be every 6 months.

### 9.2.1 Zero Calibration (Service Mode Only)

**NOTE:** This is the only advanced **SERVICE** Mode function shown in this manual.

This option will not be available unless 'Service Mode' is set on the 7300 monitor. Therefore, a zero calibration is NOT generally required for the OxyTech<sup>2</sup> GAL sensor as this has been done in the factory.

The zero value used is a true electrical zero and is achieved without any electrolyte present in the sensor. If during sensor refurbishment it is connected to the 7300 monitor without the electrolyte filling solution present, the reading displayed will check the integrity of the sensor and whether there has been water ingress into the electrode or cable assembly. If there is a positive reading of 1% or more, then the sensor should be discarded and replaced as water ingress has occurred.

If an electrical zero calibration is required then the following should be adopted.

The sensor will be dismantled with no electrolyte present. The internal anode should be clean and dry. (See sensor refurbishment below for details)



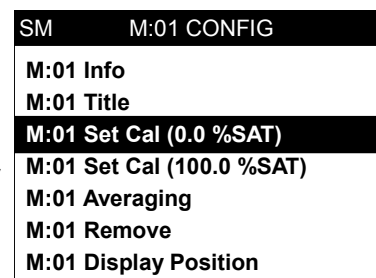
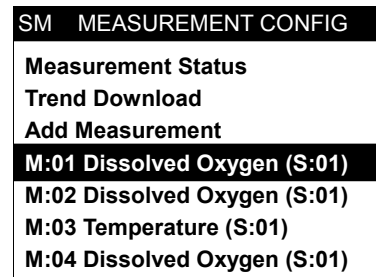

Enable 'Service Mode' . (See 7300w<sup>2</sup> instruction Manual)

From the 7300w<sup>2</sup> Monitor, navigate to the Calibration menu as follows-

- Press to show the “MAIN MENU”.
- Select “MEASUREMENT CONFIG” by pressing and press .
- Select “DISSOLVED OXYGEN” by pressing and press . NOTE: This will be the first DISSOLVED OXYGEN option as the second relates to mg/l solubility, and there is no calibration option for this measurement.





4. Select "SET CAL (0.0 %SAT)" by pressing  press  . NOTE: If this option is not displayed then SERVICE MODE is not set. ('SM' is displayed on the top left of the screen)
5. The sensor information screen will be displayed, press  to accept. The calibration screen will now be displayed with 0.0 % SAT displayed.
6. Wait for the value to stabilise (should be as close to 0% as possible), then press  to accept.

The 'Service' ZERO calibration is now complete.

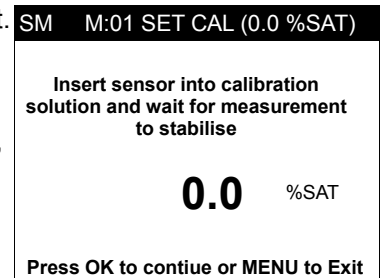

### 9.2.2 Zero Checking

This procedure is NOT a calibration but is used to check the validity of the sensor at or around zero. By purging the sensor in a solution which is anti-oxidising the reading will tend to zero. How close to zero it gets will indicate whether there is air present within the electrolyte chamber or the integrity of the membrane has been compromised. If this is the case then a full refurbishment is required. (See below)

Immerse the sensor in a water/sulphite solution (sulphite concentration: < 2%). Wait for 5 minutes before proceeding with this operation.

On the 7300w<sup>2</sup> Monitor, display observe the % saturation reading.

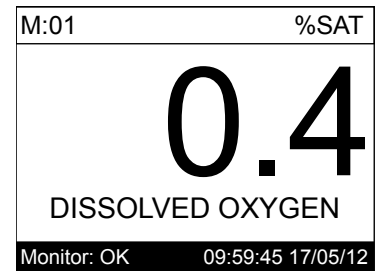











The reading should read 3.0% or below. If higher then the sensor needs to be refurbished. See Section 10 below.

### 9.2.3 SPAN Calibration

Place the sensor in air and allow the sensor to stabilise. During this period, variations caused by air flow can cause inaccuracies in the calibration. It is advisable to cover the sensor in windy conditions.

From the 7300w<sup>2</sup> Monitor, navigate to the Calibration menu as follows-

1. Wipe dry the sensor with a cloth. Place the sensor in safe place and exposing the sensor to humid oxygen saturated air.
2. Press  to show the "MAIN MENU".
3. Select "MEASUREMENT CONFIG" by pressing  and press .
4. Select "DISSOLVED OXYGEN" by pressing  and press .
5. Select "SET CAL" by pressing  and press .
6. The "SET CAL (100%SAT)" information screen will be displayed, press  to move on.
7. The calibration screen will now be displayed. Wait for the value to stabilise (*The digits should not be changing*), then press  to accept.
8. Press  several times to return back to the DISPLAY screen.

The calibration is now complete.

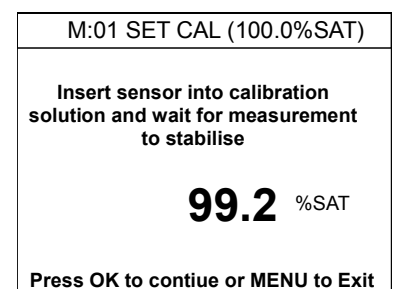
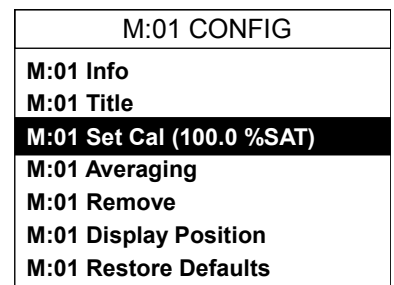
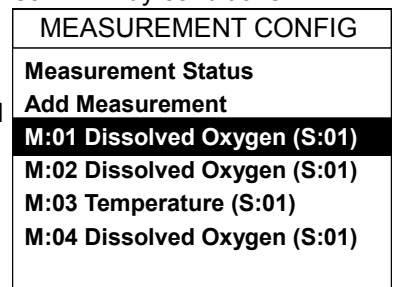

## 10 Maintenance

### 10.1 General cleaning

OxyTechw<sup>2</sup> Sensors must always be kept clean, particularly in the vicinity of the membrane. Any bio-film could lead to measurement errors.

Regular inspection and cleaning is required to ensure the sensors works to the optimum performance. Cleaning frequency will depend on the sample being measured. With a new installation, a weekly inspection is advised for the first few weeks. The condition of the sensor after these inspections will determine the frequency of cleaning thereafter.

If the membrane is dirty, clean the sensor head with warm water and soapy water. Use a sponge, but never use abrasive sponges with a scouring pad. Rinse before returning to the sample.

### 10.2 Inspection

If the sensor measures an offset in measurements during use, clean the sensor and calibrate as above.

If calibration cannot be performed (Invalid measurements or errors), the membrane and electrolyte may need to be replaced.

### 10.3 OxyTechw<sup>2</sup> GAL Refurbishment

#### Using Replacement Kit **PN225690**

Ensure you have the correct membrane to carry out the replacement. The Membrane is a D10MC membrane and comes with grey backing paper.

These sensors are type 3 sensors and denoted by the 3 dots on the top part near the cable gland, and have a type 3 anode and electrolyte. The electrolyte is blue in colour, but becomes very dark over time with deposits from the sensor.

1. Remove the sensor, and ensure it is thoroughly cleaned before attempting the unscrew the body. Unscrew the cap. If the cap is difficult to unscrew, give the body a gentle tap with a hammer to help release the cap (ensure you do not damage the body). Discard the electrolyte inside, rinse the cap and top parts of the sensor to remove any brown or black oxide deposits.

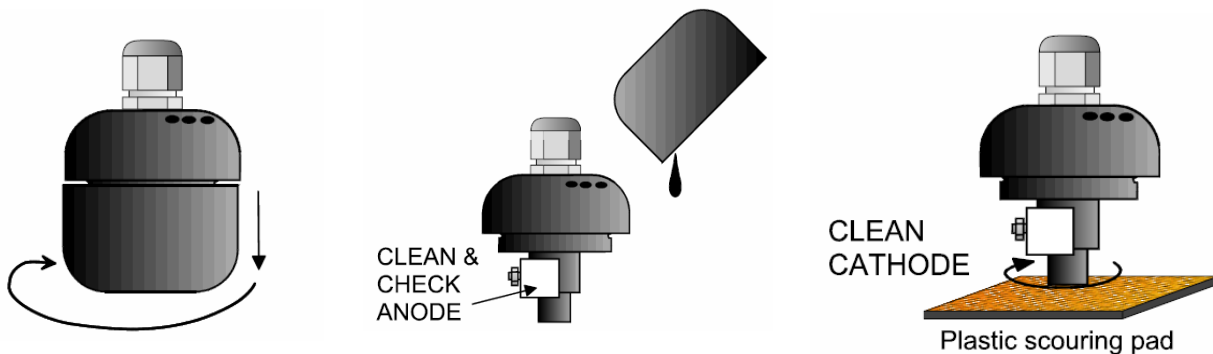

2. Inspect the anode. If the electrolyte was correctly filled during the last membrane replacement, the dark deposits should clean away easily with a small brush or similar. If the sensor was not correctly filled, the anode may be badly corroded and require replacement. Before attaching the anode (PN224697) remove any corrosion marks with 'Scotchbrite' or fine emery cloth. Discard anode if badly pitted. Wash in warm soapy water, then rinse well with deionised water before drying with paper towel. The anode is fixed onto the

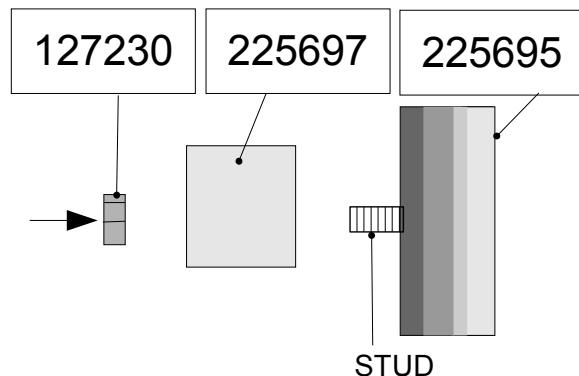

threaded stud protruding from the sensor body. Capture the anode using the nut (PN127230). Tighten nut to ensure there is good contact.

3. Check the cathode and remove any deposits using the plastic abrasive pad supplied with the sensor, or a wet and dry emery paper pad, grade 600. The cathode **MUST NOT BE POLISHED**.
4. Rinse and dry all parts again to ensure their cleanliness. .
5. With all parts dry, you can perform a quick check on the sensor while still apart. Check the signal on the 7300w<sup>2</sup> Monitor.
6. If necessary, fit a new membrane. Unscrew the membrane ring, and discard the old membrane and O ring. Clean and dry the cap to ensure there is no contamination. Replace the O ring first, followed by the membrane, and discard the backing paper (Note, the membrane is the clear part, not the grey backing paper). Tighten the ring ensuring the membrane does not wrinkle. The membrane must be flat, if it wrinkles, remove, discard and refit a new membrane.

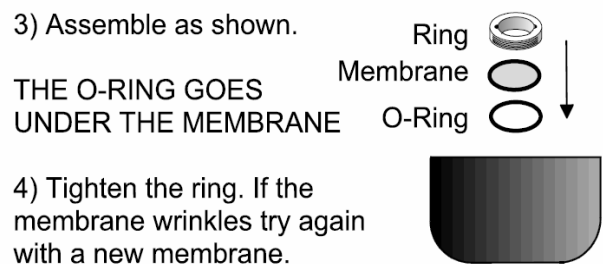
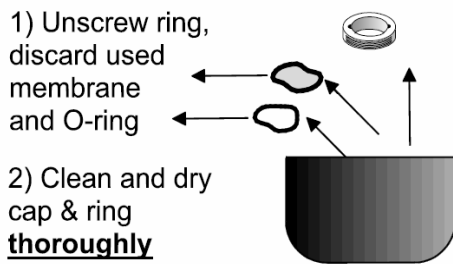
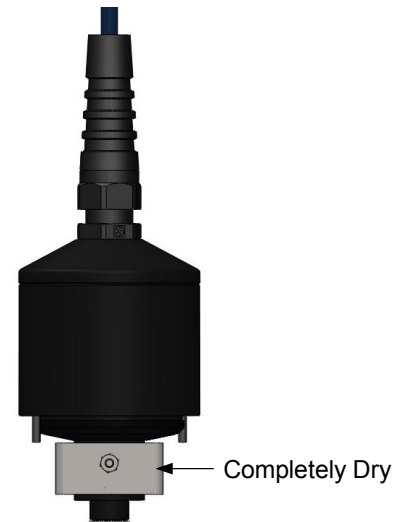

7. Fill a new cap to the brim with electrolyte. The excess electrolyte will help to remove any air bubbles during assembly.

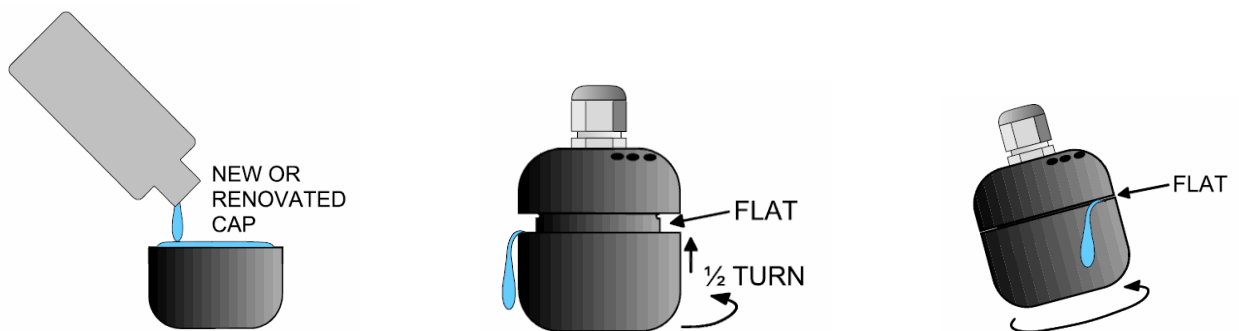

8. Locate the flat machined area on the thread. Lower the upper part into the cap and turn the cap half a turn to engage the thread.
9. Tilt the probe 15° so that the flat is uppermost and screw the cap onto the top part. Excess electrolyte and air should dribble out at the flat. **IT IS IMPORTANT THAT THE SENSOR IS FULLY FILLED WITH ELECTROLYTE.** Ensure the cap is fully tightened (as tight as you can by hand).
10. Once renovated, the sensor can be regarded as new, and therefore should follow the same procedure for installation and calibration as a new sensor. The sensor should be allowed to stabilise in air for at least 4 hours, and a full calibration performed.

## 11 Spares

225690.....OxyTechw<sup>2</sup> GAL Sensor. Refurbishment kit

*Contains: 2 X 50ml Electrolyte, 5 membranes, Scotch-Brite Pad, Instruction Manual.*

## 12 Technical Support

Technical Support is available by phone, fax, or email, the details of which are shown below.

- Phone: +44 (0) 1726 879800
- Fax: +44 (0) 1726 879801
- Email: techsupport@partech.co.uk
- Website: www.partech.co.uk

To enable us to provide quick and accurate technical support please have the following information ready when you contact us:

- Serial Number or original purchase details.
- Sensor Type, and Serial Number.
- Application details.
- Description of fault.
- Digital photos can also be useful to determine correct installation and suitability to the application.

### 12.1 Returning Equipment for Repair

If equipment needs to be returned to Partech for repair or service the following address should be used:

SERVICE DEPARTMENT  
ROCKHILL BUSINESS PARK  
HIGHER BUGLE  
ST AUSTELL  
CORNWALL  
PL26 8RA  
UNITED KINGDOM

Please include the following information with the returned equipment. Also ensure that sensor is clean and adequately protected for transportation (Advice on packing can be provided by our service department).

- Contact name and phone number of person authorising the repair
- Site details including application sample point
- Return address for equipment
- Description of fault or service required
- Any special safety precautions because of nature of application



## 13 Technical Specification – OxyTechw<sup>2</sup> GAL

### 13.1 Physical

Dimensions .....	92 x 58mm (HxDiameter)
Environmental Class.....	IP68
Enclosure Material.....	Polyoxymethylene (POM)
Weight.....	0.55 Kg (inc 10 metres of cable)
Operating Temperature.....	0 to +40° C
Storage Temperature.....	-5 to +60° C
Mounting Location.....	Indoor/Outdoor
Cable Entries.....	Integral Cable Gland
Cable Type.....	4 core, 5mm O/D Polyurethane Coated
Cable Length.....	10 metres Standard, 100 metres Max
Pressure Rating (Depth).....	2 Bar

### 13.2 Electrical

Supply.....	12VDC from 7300w <sup>2</sup> Monitor
Sensor Communication.....	Partech w <sup>2</sup> Protocol (Specifically developed for WaterWatch <sup>2</sup> range)

### 13.3 Measurement

Range.....	0-20.00mg/l or ppm 0-200 % Sat
Accuracy.....	±1% of measured value
Resolution.....	0.01
Repeatability.....	Better than ±1% FSD on real sample
Response Time.....	90% of value in less than 60 seconds
Measurement Principle.....	Galvanic oxygen partial pressure cell, self polarizing, self temperature compensating
Temperature Measurement.....	NTC

### 13.4 Mounting Options

Mounting Shaft.....	0.5 to 3 metres in 0.5 metre increments
---------------------	---

