

INSTRUCTION MANUAL

WaterTechw² C4E



**** This page is intentionally left blank ****

Table of Contents

1 Foreword.....	5
2 Introduction.....	6
2.1 Manual Conventions.....	6
2.2 WaterWatch ² Trademark.....	6
2.3 Scope of Manual.....	6
2.4 External Sensors.....	6
3 Safety Precautions.....	7
3.1 General	7
3.2 Electrical installation.....	7
3.3 Operating.....	7
3.4 Service and Maintenance.....	7
3.5 End of Life Disposal.....	8
4 The Sensor and Installation.....	9
4.1 The WaterTechw ² C4E Sensor.....	9
4.2 Mechanical Installation.....	9
4.2.1 Mounting Options.....	10
4.2.2 Mounting Shaft.....	10
4.2.3 Handrail and Wall Brackets.....	10
4.2.4 Customer Supplied Brackets.....	11
4.3 Electrical Installation.....	12
4.3.1 Electrical Installation.....	12
4.3.2 ModTechw ² Sensor Connections.....	12
4.3.3 WaterTechw ² C4E Connection Variant.....	12
4.3.4 Sensor Connections to 7300w ² Monitor.....	13
4.3.5 Extending Sensor Cables.....	13
5 Sensor Configuration.....	14
5.1 Sensor Config.....	14
5.2 Sensor Status.....	14
5.3 Add Sensor.....	14
5.4 S:0x WaterTechw ² C4E Sensor.....	14
5.4.1 S:0x Info	14
5.4.2 S:0x Remove.....	15
5.4.3 S:0x Modbus Address	15
6 Measurement configuration.....	16
6.1 Default Measurements.....	16
6.2 Measurement Status.....	16
6.3 Measurement Config.....	16
6.3.1 Add Measurement.....	16
6.3.2 M:0x Info	17
6.3.3 M:0x Averaging.....	17
6.3.4 M:0x Remove.....	17

6.3.5M:0x Display Position	17
6.3.6M:0x Restore Defaults.....	17
7 Maintenance.....	18
7.1 General cleaning	18
7.2 Calibration	18
7.3 Inspection.....	18
8 Optional Accessories.....	19
9 Technical Support.....	20
9.1 Returning Equipment for Repair.....	20
10 Technical Specification	21
10.1 Physical.....	21
10.2 Electrical	21
10.3 Measurement.....	21
10.4 Mounting Options.....	21

1 Foreword

The WaterTechw² C4E Sensor has been specifically designed for use with the 7300w² Monitor.

The WaterTechw² C4E Sensor has been designed to provide highly reliable Conductivity, Salinity and Temperature measurements. The multi-range sensor allows the same sensor to be employed in a wide variety of applications, providing the optimum accuracy and resolution for the intended application.

Conductivity is a broad measurement that indicates the level of dissolved minerals in the water. For process water, it is an indicator of the performance of the water purifier system. In some cases it can be used to prevent problems with scaling due to hardness of tap water, especially in boiler feed water. In many applications Conductivity can be used as a measurement of Total Dissolved Solids (TDS) and is a useful general indicator of water quality.

For installation in applications where fouling is anticipated we recommend that the sensor is installed using our specially designed mounting system, with a flexible joint in the mounting shaft. The flexible joint moves the sensor in the process, reducing bio-fouling and allowing rags to fall away from the assembly. This motion is similar to that achieved by using a floating ball assembly, with the added advantage of placing the sensor below the surface of the liquid. In applications where fouling is not expected or where there is insufficient space alternative mounting arrangements are available.



2 Introduction

2.1 Manual Conventions

All dimensions stated in this manual are in millimetres unless otherwise stated.

The manual has been written assuming the user has a basic knowledge of instrumentation and an understanding of the type of measurement being made. Training in the use of the 7300w² Monitor and sensors can be provided, please contact Partech for further information.

Icons have been used throughout this manual to draw your attention to precautions and useful notes.

They are categorised in the following way-



NOTES: Specifications and general notes of interest to the user.



GENERAL CAUTION – Used where caution is required to prevent injury, damage, corruption of data, loss of calibration or invalidation of warranty etc.



INSTALLATION NOTES – General installation notes of interest to the installer.



ELECTRICAL CAUTION – Used where there is a danger of electric shock to the installer or end user, or where caution is required to prevent damage to the instrument.



MAINTENANCE NOTES – Used to highlight recommended maintenance procedures and help with fault finding.



ENVIRONMENTAL NOTES – General notes on environmental issues, waste and disposal.

2.2 WaterWatch² Trademark

WaterWatchw² is the family name for the w² range of Monitors and sensors. Sensors and instruments designed for specific use with the 7300w² Monitor will be suffixed with the w² trademark.

2.3 Scope of Manual

This manual describes the installation, configuration, testing and operation of the WaterTechw² Sensor. Please refer to 7300w² Monitor manual for standard functions of the 7300w² Monitor.

2.4 External Sensors

External sensors refers to any sensors, Expansion Boxes or instruments connected externally to the 7300w² Monitor.

3 Safety Precautions



3.1 General

Read the safety precautions carefully.

Check the delivery of your WaterWatch² sensor for damage. Any damage should be reported to your supplier as soon as possible.

Use care when unpacking the sensor. **NEVER** use sharp instruments to open the packaging, as this can cause damage to the sensor or cable.

Only use accessories specifically manufactured by Partech for use with this sensor.

Read the operating instructions carefully before installing and operating this sensor.

Keep the cable connections dry and free from contamination during installation.

Keep the sensor away from high voltage cables.



3.2 Electrical installation



Only suitably qualified personnel or a competent person may install, operate or repair this equipment. The installer must ensure all electrical installations comply with local wiring regulations and standards (refer to BS7671 for UK installations).

Please check the sensor has been terminated correctly. Incorrect termination may cause damage to the sensor or monitor.

The WaterWatch² family of sensors are designed exclusively for use with the 7300w² Monitor. DO NOT connect to other monitors.

Sensors need to be correctly addressed to the monitor before use. Please read the *Sensor Configuration* sections of this manual for full details.



3.3 Operating

Because these sensors have a wide range of applications, users must acquire the appropriate knowledge to use these sensors in their specific application.

Partech are always available to provide advice and assistance in your application. Please contact Partech for further information.

These sensors must be correctly calibrated before use. Please read the *calibration* sections of this manual for full details of calibration procedures.



3.4 Service and Maintenance

Before maintenance, this equipment must be isolated or disconnected from HAZARDOUS LIVE voltages before access.

Maintenance instructions for the WaterTechw² C4E Sensor should be carried out as specified in this instruction manual. Failure to carry out regular maintenance could invalidate the Warranty.

Services and repairs must be carried out by a Partech engineer. Partech can provide a service contract for your system. Please ask for details.



3.5 End of Life Disposal

Equipment should be recycled according to local regulations.

Any calibration solutions should be disposed of as described in the Manufacture Safety Data Sheet accompanied with the calibration solution.

Partech can provide recycling and disposal of your old Partech equipment, and may also provide the same service for other manufactures equipment when replaced with Partech equipment.

Partech may provide a trade-in option for new equipment. Please contact Partech for further information.

4 The Sensor and Installation

Whilst every attempt has been made to ensure that these instructions are correct, common sense and good engineering practice should always be used, as every installation can present a new set of challenges and difficulties. If you are in any doubt please contact Partech or your local distributor for further information.

4.1 The WaterTechw² C4E Sensor

The WaterTechw² C4E Sensor works by using 4 electrodes (One pair of Graphite and one pair of Platinum). An alternating current of constant-voltage is established between a primary graphite electrode. The secondary platinum electrode allow the regulation of voltage imposed on the primary electrodes to reflect the extent of fouling. The voltage measured between the primary electrodes is measured as resistance and returns a value of conductivity.



4.2 Mechanical Installation

Reliable accurate measurement from any instrument can only be achieved by correct installation of the measuring device; in the case of the WaterTechw² C4E Sensors, this is particularly important. If you are in any doubt contact Partech or your local distributor for advice.

Below are some points that should be considered before starting to install the sensor, or in the event an installed sensor gives unreliable measurements-

- Ensure that the sensor is immersed deeply enough into the sample.
- The sensor should be mounted in such a way as to allow easy access for calibration and maintenance. It should be possible to remove the sensor from the process without the need to shut the process down.
- The sensor must be monitoring a sample of the process that is representative of the whole process.
- To allow a single technician to calibrate and maintain the system the sensor should be placed within sight of the 7300w² Monitor. Although cable runs of up to 100 metres are possible operational problems can be caused.
- When possible, angle the sensor so that it is pointing down stream, this will allow any “ragging” to be removed by the flow past the sensor.
- Do not install where there is a likelihood of freezing.

4.2.1 Mounting Options

Partech offer a range of mounting brackets for the installation of the WaterTechw² C4E sensor, which will allow the user to apply the sensor in a wide variety of locations. Drawings of the brackets are shown in the relevant "Optional Accessories" sections of this manual. When assessing mounting options, attention should be paid to the accessibility of the sensor for calibration and maintenance, stability of the sensor in the flow conditions present on site and to ensuring the sensor is fully submerged at all times.



4.2.2 Mounting Shaft

An optional mounting shaft fitting can be used to allow the WaterTechw² C4E Sensors to be fitted to a number of mounting accessories. Partech supply mounting shafts manufactured from 2" nominal bore grey ABS pipe in 0.5, 1.0, 1.5, 2, 2.5 and 3.0 metre lengths. Whilst other lengths can be provided as special orders, generally standard lengths will satisfy most requirements. It should be noted that sensors with long mounting shafts are difficult to move safely and can present problems with calibration and maintenance, shaft lengths should be kept to a minimum where possible.

4.2.3 Handrail and Wall Brackets

The mounting shafts described above need to be attached to the structure of the tank or flow channel where measurement is required. The mounting shaft sits inside the mounting bracket and is located using locking collars. To remove the mounting shaft, remove the locking thumb screw and lift the shaft from the bracket.

Care should be taken to ensure that the sensor can be reached from the walkway to allow removal for calibration and maintenance.

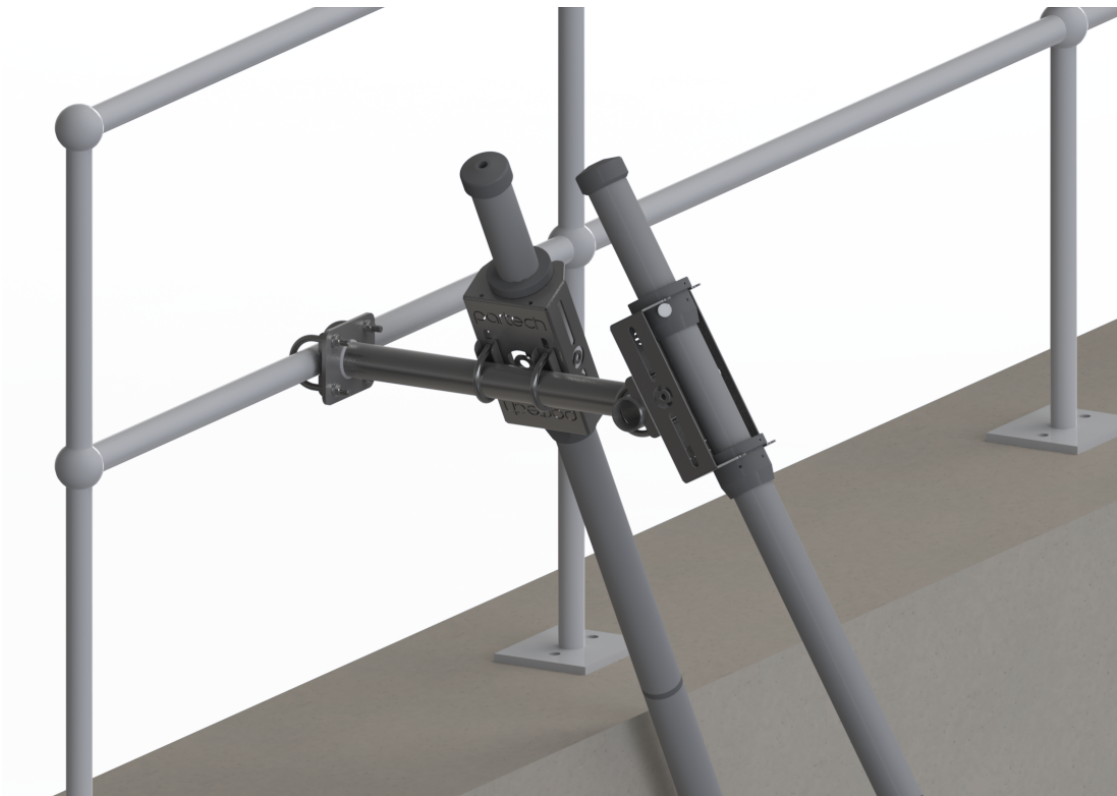

4.2.4 Customer Supplied Brackets

When creating brackets to mount the WaterTechw² C4E Sensors, care should be taken to ensure that the following guidelines are observed:

- The bracket must be strong enough to support the sensor with minimum movement when installed into the sample.
- The sensor should be fitted by clamping around the sensor body or suspended by the cable.
- Consideration should be given to enable simple removal and replacement of the sensor for inspection, calibration and servicing to be carried out.

4.3 Electrical Installation

4.3.1 Electrical Installation

Unscrew the two cover screws on the lower panel of the 7300w² Monitor to reveal the Terminals. Each terminal strip is labelled as illustrated below. (This equipment must be isolated or disconnected from HAZARDOUS LIVE voltages before access). Refer to the 7300w² Monitor user manual for full description of all the terminals within the monitor.

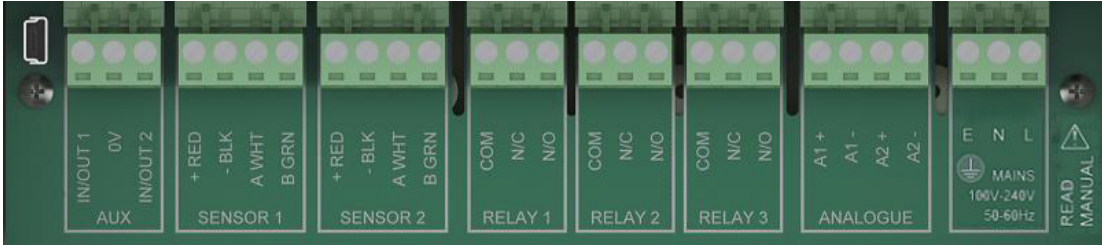

The maximum size wire that can be terminated is 2.5mm² CSA. All the connections are via removable Plug/Socket terminals. To disengage the terminal strip, simply pull down to release.

4.3.2 ModTechw² Sensor Connections

When routing the sensor cables, please ensure the cable is separated from any mains cables. Although Waterwatch² sensors have a high resistance to interference, separation of mains and data cables is good practice and should always be followed where practical.

All sensors in the w² range communicate with the monitor using the ModTechw² Protocol. This protocol has been specifically designed to take advantage of the advanced features and diagnostics designed into the w² range of sensors.

Note- These sensors can **NOT** be used with other Monitors that are not included in the w² family.

All sensors within the w² family of instruments are connected to the 7300w² Monitor using the same 4 wire configuration.

- RED and BLACK wires provide the 12VDC supply to the sensor.
- WHITE and GREEN provide data communication.
- SCREEN connected with BLACK wire.

4.3.3 WaterTechw² C4E Connection Variant

The WaterTechw² C4E Sensor also has other colours within the cable:

- BLUE is left unconnected when configured with the 7300w² Monitor.
- PURPLE, YELLOW, ORANGE, PINK are +12 volt wires and are connected to the same terminal as RED

These positive power wires are already marshalled together into a double entry bootlace ferrule to allow ease of connection to the 7300w² Monitor.

The extra +12 volt wires are only visible on WaterTechw² C4E Sensors with cable lengths greater than 15 metres.

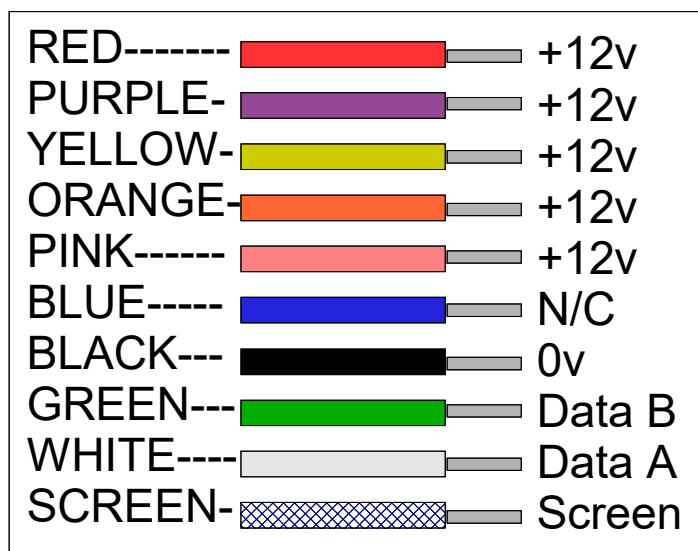

4.3.4 Sensor Connections to 7300w² Monitor

A maximum of two sensors can be directly connected to the standard 7300w² Monitor, however additional sensors can be added using the optional expansion module available separately.

Remove the 4-way connector from the 7300w² Monitor by pulling downwards to disconnect for easy access to the connections. Connect the sensor cores as follows-

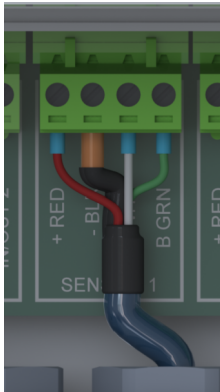

(Terminals from left to right on the 4 way connector)

Term 1 (Left)	-	RED (+12V)
Term 2	-	Black (0V)
Term 3	-	White (Data A)
Term 4 (Right)	-	Green (Data B)

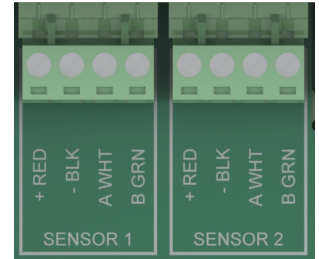

Always connect the screen drain wire with the Black (Term 2). Illustration Left shows drain wire and Black wire connected together, and covered in Black Heat shrink.

Always use Bootlace ferrules when terminating the sensors to ensure a good connection to the terminals.

4.3.5 Extending Sensor Cables

Sensors are usually supplied with 10M cables (longer cables can be provided if requested). These cables can be extended to a maximum length of 100M. To ensure optimum performance, only use Partech ModTechw² cable for extensions. Partech can supply Junction Boxes to allow for cable extensions. These junction boxes should be used on all installations where the cable length from the sensor to the Monitor exceeds 20m (Junction Boxes include filtering for long cable lengths). Junction Boxes are also useful for local connection of sensors close to the sample point. This allows for easy replacement of sensors without the need to pull the cables right back to the monitor. The Junction Boxes also include a switchable network terminator, useful to terminate cable runs if the sensor is to be removed for long periods.

When joining cables, ensure the connection is fully waterproof. Any moisture ingress can effect the communication between the sensor and Monitor.

ModTechw² Cable specification-

- 2 Twisted Pair - Red/Black (Power) and Green/White (Data) with Screen and Drain wire
- Cores 24AWG (0,22mm²) 7 x 0,20mm
- Outer Insulation – PUR Polyurethane Blue (RAL5003), Diameter – 5mmØ

Important note about the WaterTechw² C4E Sensor cable.

The above specifications show the colours for the standard ModTechw² Cable. It will be noted that the WaterTechw² C4E Sensor has a Black outer insulation and extra wires; blue, purple, yellow, orange and pink. Please observe the colour specification as designated above and that only 2 Twisted Pairs are required to extend the cable as PURPLE, YELLOW, ORANGE, PINK are +12 volt wires and are connected to the same terminal as RED. The BLUE wire is unused and can be trimmed off.

5 Sensor Configuration

Before attempting to configure the sensor, please read the user manual that came with your monitor. The monitor manual will introduce you to the basic set-up of the monitor, and will familiarise you with the monitor menu structure and buttons.

The monitor leaves the factory with no sensors pre-installed.

Assuming the monitor has been physically connected to a sensor, the next step is to register and configure the sensor before any measurements can be made. A single sensor will provide more than one measurements. We advise only connecting one sensor at a time. Once the first sensor has been registered, connect the second and register again. Repeat for any additional sensors.

All sensors must be registered to the monitor in this way, even if they are different types.

Please note that live measurements are not available until the Measurement Config stage has been completed.

5.1 Sensor Config





From the MAIN MENU screen, select SENSOR CONFIG by pressing , and press .

5.2 Sensor Status



This option allows the user to review the current status of the 8 sensor channels, these will all be set to disabled until a sensor is added.

Once a sensor has been installed the display will be updated to indicate the sensor type installed and it's status.

5.3 Add Sensor

1. From the MAIN MENU screen, select SENSOR CONFIG by pressing , and press .
2. The SENSOR MENU should be displayed. Press  to highlight ADD SENSOR, and press .
3. The Monitor will now search all possible addresses (0 to 240) to find any attached sensors. During the search, any sensors found will be displayed momentary before continuing with the search.
4. Once the search is complete, the Monitor will display a list of sensors found. Each sensor will be automatically allocated a new address from S:01 to S:08.
5. Repeat the above process to install a second, third or more sensors. A total of 8 sensors are possible (expansion box may be required to add additional sensors).
6. Sensor addition is now complete.

5.4 S:0x WaterTechw² C4E Sensor

Once the sensor has been added and registered, the monitor will provide a list of functions specific to the sensor. Press  or  to select the sensor and press . The CONFIG MENU will display a list of sensor functions.

5.4.1 S:0x Info

This function provides a range of diagnostic information that may be requested by Partech for fault finding

5.4.2 S:0x Remove



This allows the sensor to be removed for re-configuration of the monitor or if a sensor has been added on error. If a sensor has been replaced with a new sensors, the old sensor must be removed, and the new sensor installed.

You will be prompted with 'Are you sure?' before the sensor is removed. Press  to accept and remove.









5.4.3 S:0x Modbus Address

All Waterwatch² sensors and Expansion Boxes communicate with the monitor using the ModTechw² Protocol. This protocol is a modified Modbus Protocol, and has been specifically developed to take advantage of the advanced features and diagnostics designed into the w² range of sensors. The term "Modbus Address" has been used as a generic term to describe the address of each sensor and Expansion Box on the Modtechw² network.

Once the first sensor has been configured, it may be necessary to change the Modbus Address before connecting a second sensor, especially if they are of the same type. If only one sensor is to be connected to the 7300w² monitor or several sensors of different types, it is not necessary to change the Modbus Address.

All sensors and Expansion Boxes have default addresses starting from address 10 to 240, leaving addresses 1-9 free for user configuration. It is good practice to allocate Sensors 1-8 to Modbus Address 1-8.

The following describes how to manually change the Modbus address of a sensor:

1. From the SENSOR CONFIG screen, use  or  to highlight the sensor to be re-addressed i.e. "S:01 WaterTechw² C4E)", then press  to select.
2. Select MODBUS ADDRESS and press  to select.
3. Press  or  to move the cursor below the digit to be changed.
4. Press  or  to increase or decrease the digit.
5. Press  to accept.



Once the Modbus address has been changed, you are then free to configure the next sensor. Note: The Modbus address is stored in the sensor not the monitor.

6 Measurement configuration

The monitor leaves the factory without any measurements configured. Measurements can only be added once the sensor(s) have been configured. It is not possible to configure a measurement before sensors configuration.

6.1 Default Measurements

Once the sensor has been configured, default measurements will be automatically installed. In the case of the WaterTechw² C4E, default measurements are :

- Conductivity Range 2000uS/cm
- Temperature °C

Additional measurements are available for this sensor. These can be added to the list of measurements, alternatively, the defaults measurements can also be removed (i.e if for example 200uS/cm needs to be removed and 20uS/cm installed).

6.2 Measurement Status

This option allows the user to review the current status of the 16 measurement channels. Configured measurements will show the type of measurement and description and serial number of the sensor providing the measurement. If only one measurement is configured, the remaining fifteen measurement allocations will display “DISABLED”.

6.3 Measurement Config

From the MAIN MENU screen, select MEASUREMENT CONFIG using to highlight and press .

6.3.1 Add Measurement

1. From the MAIN MENU screen, select MEASUREMENT CONFIG by pressing or , and press .
2. The MEASUREMENT MENU should be displayed. Press to highlight ADD MEASUREMENT, and press .
3. All available measurements will be displayed in a list. Press or to highlight the first measurement.
4. Press to select the measurement. Repeat the process if more measurements are required.
5. Each measurement will be allocated a measurement number from M01 – M16. A total of 16 measurements may be displayed.

N.B. The measurement number has no relevance to the sensor number.

6. Press to return back to the display screen. The first configured measurement should now be displayed.

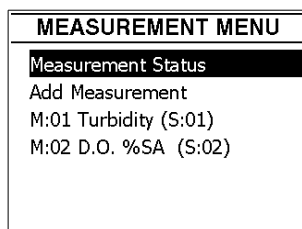

The Measurement Menu will list all configured measurements in order M:01 to M:16 the list will also indicate the sensor number that is delivering the signal for the measurement. (Note: the above screen shot is an example of measurements loaded from a Turbidity sensor).

6.3.2 M:0x Info







This option provides additional information for the measurement this information will only be required if a problem exists with the instrument performance.

6.3.3 M:0x Averaging

This allows the user to impose averaging on the measured value, used to reduce the speed of reaction to the process changes. The value can be adjusted between 0 and 6000, the higher the value the slower the reaction time.

6.3.4 M:0x Remove

If a measurement is no longer required, the measurement configuration can be removed from the 7300w² monitor in the following way.

1. From the MEASUREMENT CONFIG screen, use  or  to highlight the measurement to be removed i.e. "M:01 Turbidity (S:01)", then press  to select.
2. Select REMOVE and press  to select.
3. Screen will display "Are you sure?". Press  to remove or  to exit without removing.











Once removed, any Alarms or Analogue outputs configured to the measurement will also be removed.

6.3.5 M:0x Display Position

Display Position allows two measurement to swap places, to allow the user to re-arrange the display as required. The display position refers to the M:0# number allocated to the measurement. The screen will always display the measurements in order from M:01 to M:16.

To swap measurements, use the DISPLAY POSITION menu.

The example below swaps measurement M:01 with M:03:

1. From the MEASUREMENT CONFIG screen, use  or  to highlight the measurement to be moved i.e. "M:01 Turbidity (S:01)", then press  to select.
2. Select DISPLAY POSITION using  or  and press  to select.
3. The current display position will be shown, e.g. 1 for M:01 Turbidity.
4. Press  or  to move the cursor below the digit to be changed.
5. Press  or  to increase or decrease the digit to the desired new position (e.g. 3)
6. Press  to accept. Measurement M:01 will now become Measurement M:03, and the measurement registered as M:03 will now become measurement M:01.
7. Note: any alarms or analogue outputs registered to a specific measurement will also be updated to the new display position (it is not necessary to re-configure alarms or analogues).

6.3.6 M:0x Restore Defaults

Selection of Restore Defaults will restore the sensor back to the factory default settings.



7 Maintenance

7.1 General cleaning

The sensor requires periodic cleaning.

Remove the sensor from the sample, and clean with a cloth. Run an abrasive band through the metering slot under running water. Re-calibrate the sensor.

7.2 Calibration

This sensor does NOT require routine calibration. The sensor is factory calibrated and ready to use out of the box.

7.3 Inspection

The sensor does not require any specific inspection or maintenance. A general inspection for cleanliness should be performed periodically, and cleaned as described above.

8 Optional Accessories

Partech have a full range of brackets and mounting shafts for a number of application. Please contact Partech for details.

Example of our standard hand rail bracket

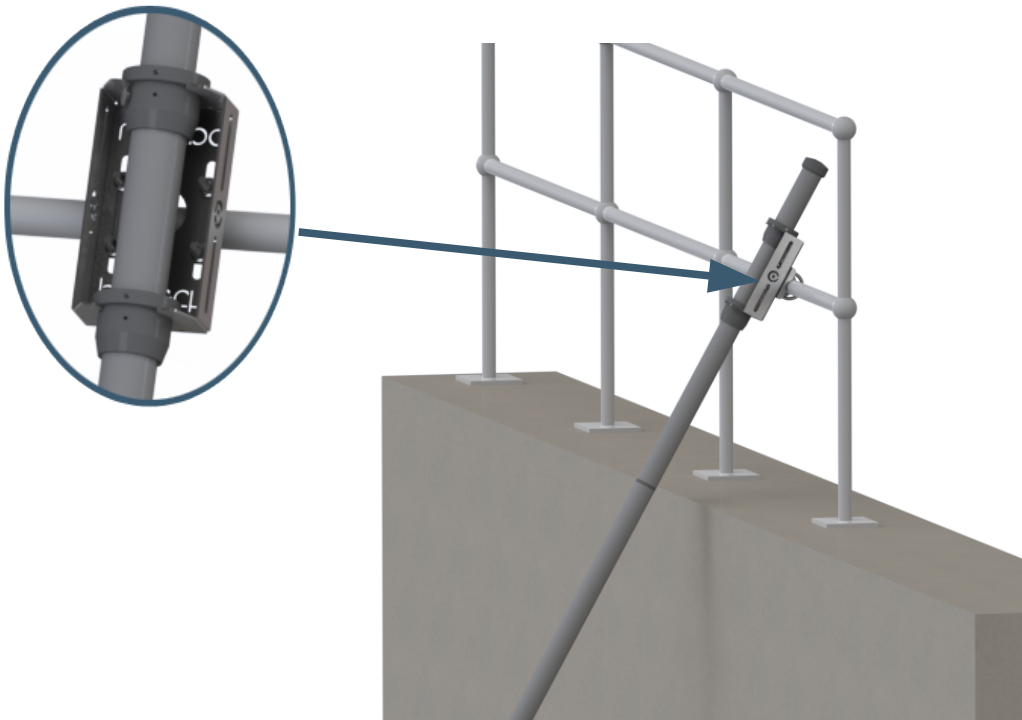
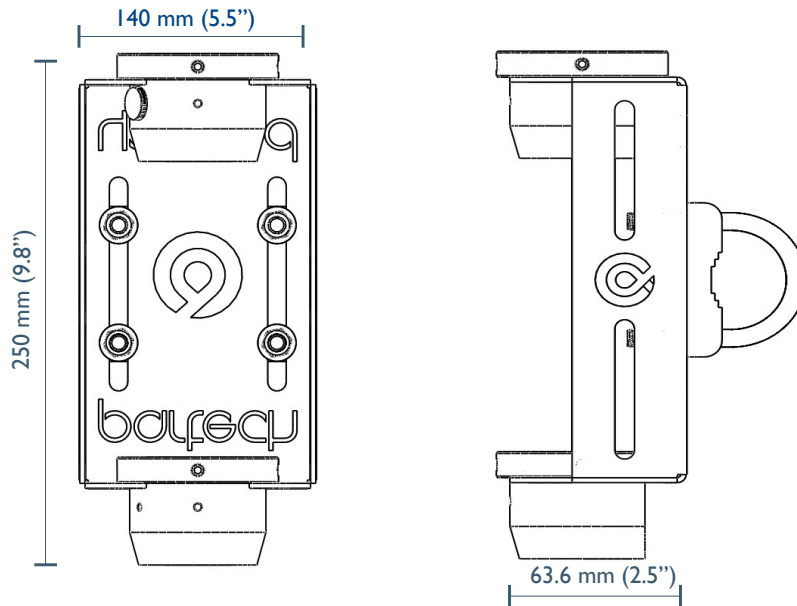

9 Technical Support

Technical Support is available by phone, fax, or email, the details of which are shown below.

- Phone: +44 (0) 1726 879800
- Fax: +44 (0) 1726 879801
- Email: techsupport@partech.co.uk
- Website: www.partech.co.uk

To enable us to provide quick and accurate technical support please have the following information ready when you contact us:

- Serial Number or original purchase details.
- Sensor Type, and Serial Number.
- Application details.
- Description of fault.
- Digital photos can also be useful to determine correct installation and suitability to the application.

9.1 Returning Equipment for Repair

If equipment needs to be returned to Partech for repair or service the following address should be used:

SERVICE DEPARTMENT
PARTECH INSTRUMENTS
ROCKHILL BUSINESS PARK
HIGHER BUGLE
ST AUSTELL
CORNWALL
PL26 8RA
UNITED KINGDOM

Please include the following information with the returned equipment. Also ensure that sensor is clean and adequately protected for transportation (Advice on packing can be provided by our service department).

- Contact name and phone number of person authorising the repair
- Site details including application sample point
- Return address for equipment
- Description of fault or service required
- Any special safety precautions because of nature of application



10 Technical Specification

10.1 Physical

Dimensions 177 x 27mm (HxDiameter)
 Environmental Class.....IP68
 Enclosure Material.....PVC Body, Stainless Steel
 Weight.....0.35Kg (inc 10 metres of cable)
 Operating Temperature.....0 to +50° C
 Storage Temperature.....-10 to +60° C
 Mounting Location.....Indoor/Outdoor
 Mounting.....Dip
 Cable Entries.....Integral Cable Gland
 Cable Type.....6 core, 5mm O/D Polyurethane Coated
 Cable Length.....10 metres Standard, 100 metres Max
 Pressure Rating (Depth).....5 Bar

10.2 Electrical

Supply.....12VDC from 7300w² Monitor
 Sensor Communication.....Partech w² Protocol (Specifically developed for WaterWatch² range)

10.3 Measurement

WaterTechw² Measurement	Range	Accuracy	Resolution	Measurement Principle
Conductivity	0 – 200µS/cm 0 – 2,000µS/cm 0 – 20mS/cm 0 – 200mS/cm	±1% FSD	0.01 to 1 according to range	4 Electrode (2 Graphite, 2 Platinum)
Temperature	0 - 50° C	±0.5° C	0.01° C	NTC
Salinity (ppt)	5 – 60ppt (g/Kg)			
Salinity (TDS)	0-133,000 ppm			

Response Time.....<5 seconds
 Flow Rate.....No flow necessary

10.4 Mounting Options

Mounting Shaft.....0.5 to 4 metre in 0.5 metre increments

