

EXTECH

Quick Start

True RMS Industrial Multimeter

MODEL EX505A

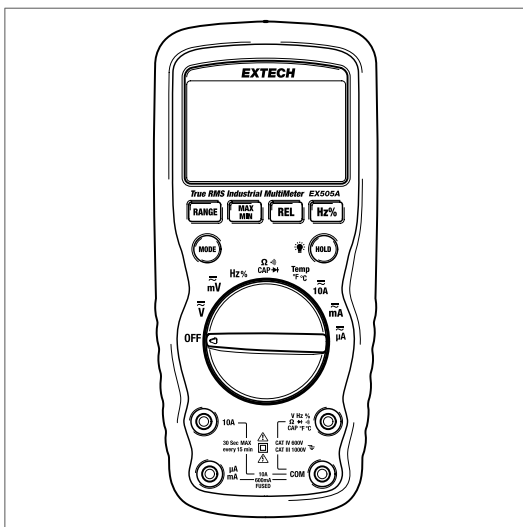

Quick Start (EN)

INTRODUCTION

The Extech EX505A measures AC/DC Voltage, AC/DC Current, Resistance/Continuity, Capacitance, Frequency/Duty Cycle, Diode, and Temperature. This meter features a water-proof, rugged design intended for industrial use.

DOCUMENTATION ADVISORY

This Quick Start is intended for setup and reference only, please download and read the User Manual before taking measurements (link below). Additional translations of this Quick Start may also be available.

<https://support.flir.com>

SAFETY



WARNING

- Improper use of this meter can cause damage, shock, injury or death. Download, read and understand the User Manual before use.
- Use caution when working with signals > 60 V DC or 30 V AC RMS.
- Never ground yourself when taking electrical measurements.
- Keep your fingers behind the finger guards on the test lead probes.
- Turn off power to the circuit under test before opening the circuit.
- Always discharge capacitors and remove power from the device under test before performing Diode, Resistance or Continuity tests.
- Never connect the meter leads across a voltage source while the function switch is in the current, resistance, or diode mode.
- When changing ranges, always disconnect the test leads from the circuit under test.
- Some test lead probe tips may not be long enough to reach the live parts inside some voltage outlets because the contacts are recessed deep in the outlets. As a result, the reading may show zero volts when the outlet is actually live.

Input Protection Limits

Function	Maximum Input
AC/DC Current (A)	10 A (1000 V) fast acting fuse (30 seconds maximum at 15 minute intervals)
AC/DC Current (mA, μ A)	600 mA (1000 V) fast acting fuse
AC/DC Voltage	1000 V DC and AC RMS
Frequency, Resistance, Capacitance, Diode, Temperature	250 V DC and AC RMS

QUICK STEPS





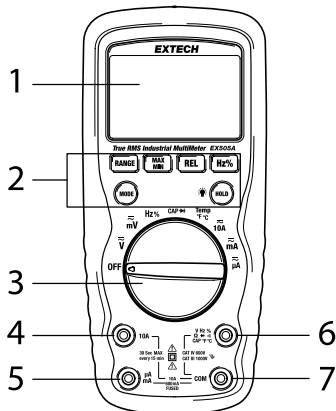

1. Connect test lead plugs to the jacks at the bottom of the meter.
2. Turn the function switch to the desired measurement position.
3. For all functions, except current, touch the test lead tips across the circuit or component under test.
4. For current measurements, the test lead tips must be placed in series with the circuit under test.
5. Use the **MODE** button to select AC, DC, or other modes.
6. View the measurement and multifunction indicators on the LCD.
7. Turn the function switch to the OFF position, when finished.

METER DESCRIPTION

1. Backlit LCD with bar graph.
2. Control buttons.
3. Function switch.
4. 10 A positive test lead input.
5. μ A and mA positive test lead input.
6. Voltage, frequency, duty cycle, resistance, diode, continuity, capacitance, temperature positive test lead input.
7. Negative (common) input test lead input.



CONTROL BUTTONS

	Short press MODE to select an alternate mode for the function in use.
	Short press to freeze/unfreeze reading. Long press to switch the backlight on/off.
	Short press to switch to Manual range and then to change ranges. Long press to return to Auto range.
	Short press to step through MAX, MIN, and MAX minus MIN readings. Long press to exit.
	Press to store the reading as a reference. Subsequent readings = measurement minus reference.
	When measuring AC current or voltage, press to step to frequency, duty cycle, and back to normal operation. When measuring electronic frequency, press to toggle Hz and %.

DISPLAY DESCRIPTION

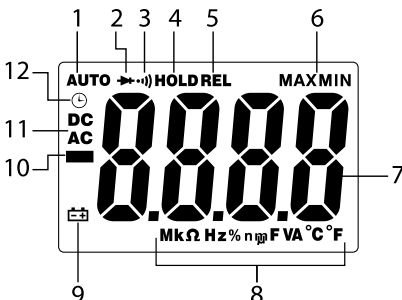
<ol style="list-style-type: none"> 1. Auto range. 2. Diode. 3. Continuity. 4. Data Hold. 5. Relative (zero). 6. Maximum and Minimum readings. 7. Measurement reading. 8. Unit of measure and range prefixes. 9. Low battery. 10. Negative polarity (minus). 11. Alternating or Direct Current. 12. Auto Power Off enabled. 	 <p>The diagram shows a digital display with four segments. Above the segments are indicators: 1 (AUTO), 2 (diode symbol), 3 (continuity symbol), 4 (HOLD), 5 (REL), and 6 (MAX MIN). To the left of the segments are indicators: 12 (battery symbol), 11 (DC/AC), and 10 (minus sign). Below the segments are units: 8 (MkΩ, Hz, %, npp, F, VA, °C, °F) and 7 (the main reading area).</p>
--	---

METER POWER

The meter is powered by one 9 V battery. The compartment is located on the back of the meter (under the tilt stand) secured by the

two black Phillips screws. The meter automatically switches off after approximately 15 minutes.

FEATURES

Automatic and Manual Range

In the current, voltage, resistance, and capacitance modes, the meter automatically selects the optimum range. To use manual range, press the **RANGE** button, subsequent presses will step through the ranges. Long press **RANGE** to return to Auto range.

Data Hold

To freeze the displayed reading, press the **HOLD** button, the HOLD icon will appear. Press the **HOLD** button to return to normal operation.

Maximum and Minimum Readings

Press the **MAX/MIN** button to toggle the maximum and minimum reading displays. The **MAX** and **MIN** display icons show the selected mode. Long press the **MAX/MIN** button to exit.

Relative (REL) Mode

The Relative feature allows you to make measurements relative to a stored reference. The displayed value is the difference between the reference and the measured value.

Press the **REL** button to store the reference (REL will appear). The display will now indicate the difference between the stored value and the measured value. Press **REL** to exit.

MEASURING VOLTAGE, FREQUENCY, RESISTANCE, DIODE, CAPACITANCE

Voltage, frequency, resistance, diode, and capacitance measurements are made with the test leads placed 'across' the device or circuit under test (in parallel).



WARNING

Risk of electrocution. High-voltage AC and DC circuits are extremely dangerous and should be measured with great care.

Do not measure resistance, diode, or capacitance on powered devices. Remove power before making these measurements.

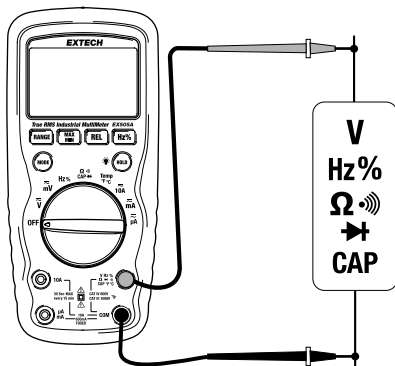

1. Rotate the function switch to the desired function. Use the **MODE** button to select resistance, continuity, diode, or capacitance as necessary.
2. Insert the black test lead plug into the negative **COM** jack. Insert the red test lead plug into the positive jack.
3. Touch the black test probe tip to the negative side of the circuit. Touch the red test probe tip to the positive side of the circuit.
4. Read the measurement value on the display.

MEASURING CURRENT

Current measurements are made with the test leads placed in series with the circuit under test.



WARNING

Do not make 10 A current measurements for longer than 30 seconds.

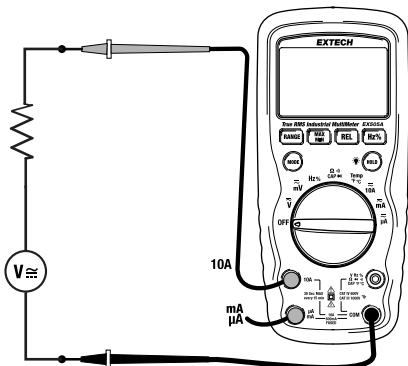

1. Rotate the function switch to the desired current function. Use the **MODE** button to select AC or DC.
2. Insert the black test lead plug into the negative **COM** jack. Insert the red test lead plug into the positive **10A** or **mA/μA** jack.
3. Remove power to the circuit under test and place the test lead tips in series with the circuit.
4. Apply power to the circuit under test and read the measurement value on the display.

TYPE K TEMPERATURE MEASUREMENTS

CAUTION: The supplied thermocouple is rated for 482°F (250°C) maximum.

1. Rotate the function switch to the **TEMP** position. Press **MODE** to select °F or °C.
2. Insert the temperature probe into the test lead jacks, observing correct polarity.
3. Touch the probe tip to the surface under test. Read the temperature measurement on the display.

BASIC SPECIFICATIONS

For complete specifications, please download the user manual.

Display	Backlit LCD with bar graph
Over-range indication	OL display
Battery power	9 V battery
Operating temperature	32 to 122°F (0 to 50°C)
Operating humidity	< 70% RH
Dimensions	7.2 x 3.3 x 2.2 in. (183 x 83 x 55 mm)
Weight	0.8 lbs. (365 g)
Safety	Meter: Over-voltage CAT IV 600 V, CAT III 1000 V, Pollution Degree 2 Supplied test leads: Over-voltage CAT IV 600 V, CAT III 1000 V
Agency approvals	UL, CE, UKCA
Fuse types	600 mA (1000 V) ceramic fast blow (600 mA range) 10 A (1000 V) ceramic fast blow (10 A range)
Input impedance	> 10 MΩ (Voltage AC/DC)
AC bandwidth	50 Hz to 1 kHz (AC voltage); 50/60 Hz (AC current)
AC response	True RMS (AC voltage/current)
Supplied Thermocouple	Type K; rated 482°F (250°C) maximum

CUSTOMER SUPPORT

Customer Support Local Telephone List:

<https://support.flir.com/contact>

Returns (RMA):

<https://customer.flir.com/Home>

WARRANTY

Teledyne FLIR warrants this Extech brand instrument to be free of defects in parts and workmanship for three years from date of shipment. To view the full warranty text, please visit the support site, link below.

<https://www.flir.com/support-center/warranty/>

Website

<http://www.flir.com>

Customer support

<http://support.flir.com>

Copyright

© 2024, FLIR Systems, Inc. All rights reserved worldwide.

Disclaimer

Specifications subject to change without further notice. Models and accessories subject to regional market considerations. License procedures may apply.

Products described herein may be subject to US Export Regulations. Please refer to exportquestions@flir.com with any questions.

Publ. No.: NAS100188
Release: AH
Commit: 98045
Head: 98046
Language: en-US
Modified: 2024-05-20
Formatted: 2024-05-20

