

EXTECH

Quick Start

1000 A True RMS AC/DC Clamp Meter with IR Thermometer

MODEL EX840A

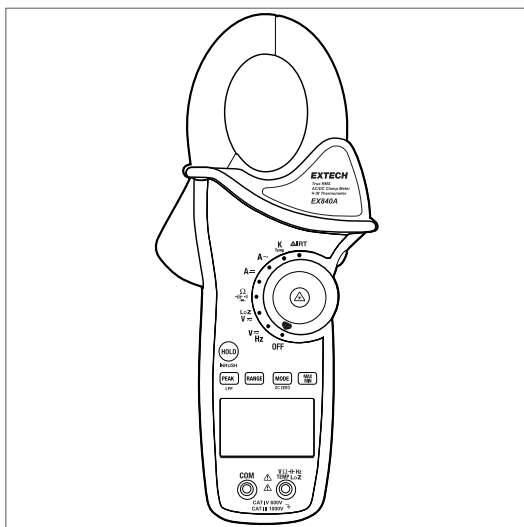

Quick Start (en)

INTRODUCTION

The Extech EX840A measures AC/DC Current, AC/DC Voltage, Resistance/Continuity, Capacitance, Diode, Frequency, and Temperature (IR detection and Type K thermocouple). The double moulded case is designed for heavy duty use.

DOCUMENTATION ADVISORY

This Quick Start is intended for setup and reference only, please download and read the User Manual before taking measurements (link below). Additional translations of this Quick Start may also be available.

<https://support.flir.com>

SAFETY



WARNING

- For indoor use only.
- Improper use of this meter can cause damage, shock, injury or death.
- Set the function switch to the appropriate position before measuring.
- When measuring voltage do not switch to the current or resistance modes.
- Do not measure current on a circuit whose voltage > 600 V.
- When changing ranges, always disconnect the test leads from the circuit under test.
- Voltage checks on electrical outlets can be difficult and misleading because of the uncertainty of connection to the recessed electrical contacts. If connection to the contacts is not made, the outlet may be live when the meter indicates no voltage.



CAUTION

- Always remove the test leads before replacing the battery.
- Inspect the condition of the test leads and the meter itself for any damage before operating the meter.
- Use caution when making measurements if the voltage > 25 V DC or 35 V AC RMS.
- Always discharge capacitors and remove power from the device under test before performing Diode, Resistance or Continuity tests.
- If the equipment is used in a manner not specified by the manufacturer, the protection provided by the equipment may be impaired.
- **Do not directly view, point, or reflect the laser pointer towards the eyes.**
- Use of controls or adjustments or performance of procedures other than those specified herein may result in hazardous radiation exposure.



LASER RADIATION - DO NOT STARE INTO BEAM
RAYONNEMENT LASER NE REGARDEZ PAS LE FAISCEAU
CLASS 2 CONSUMER LASER PRODUCT

WAVELENGTH: 650nm MAX OUTPUT POWER < 1mW

IEC 60825-1:2014

COMPLIES WITH 21 CFR 1040.10

AND 1040.11 EXCEPT FOR

CONFORMANCE WITH IEC 60825-1

ED. 3 AS DESCRIBED IN LASER

NOTICE NO. 56, DATED MAY 8, 2019.

EN 60825-1:2014/A11:2021, EN 50689:2021

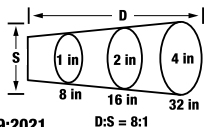

Laser light beam divergence

0.5 to 0.6 in. (12 to 15 mm) typical spot diameter at a distance of 32.8 ft. (10 m)

Maximum Input Ranges

Function	Maximum Input
AC/DC Current	1000 A AC/DC
AC/DC Voltage	1000 V AC/DC
AC/DC Voltage (LoZ)	600 V AC/DC
Resistance, Capacitance, Frequency, Diode	250 V AC/DC
Type K Temperature	60 V DC, 24 V AC





METER DESCRIPTION

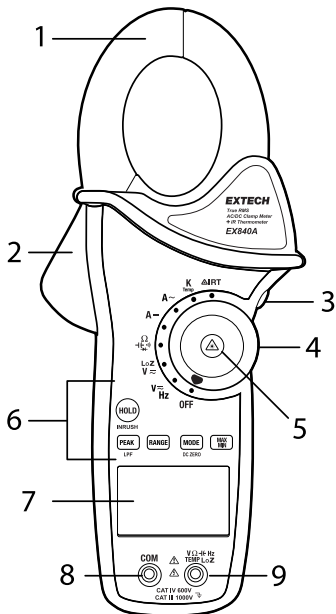

1. Current clamp.
2. Clamp trigger.
3. Backlight button.
4. Function switch.
5. IR measure button.
6. Control buttons.
7. Backlit LCD.
8. Negative test lead jack.
9. Positive test lead jack.

Battery compartment and lenses on back of meter.



CONTROL BUTTONS

	Set function switch to the IRT position, then hold this button to scan surface temperature.
	Press to switch LCD backlight on or off.
	Short press to freeze/unfreeze the reading. Long press to enable/disable the inrush current circuit when measuring AC current.
	Short press to show/hide the measured signal's peak. Long press to engage or remove the low pass filter, for measuring AC voltage.

	Short press to switch to the manual range and then to step through the available ranges. Long press to return to Auto range.
 DC ZERO	Short press to select an alternate mode for the selected function. For example, to select AC or DC when measuring voltage. Long press to null the display when in the DC current mode.
	Short press to toggle the Maximum and Minimum readings. Long press to exit.

METER POWER

The meter is powered by one 9 V battery. The compartment is located on the back of the meter. The meter automatically switches off after approximately 15 minutes.

FEATURES

Automatic and Manual Range

In the voltage, resistance, capacitance, and frequency functions, the meter automatically selects the optimum range. To use manual range, press the **RANGE** button, subsequent presses will step through the available ranges. Long press **RANGE** to return to Auto range.

Data Hold

To freeze the displayed reading, press the **HOLD** button, the HOLD icon will appear. Press the **HOLD** button to return to normal operation.

Maximum and Minimum Readings

Press the **MAX/MIN** button to toggle the maximum and minimum reading displays. The **MAX** and **MIN** display icons show the selected mode. Long press the **MAX/MIN** button to exit.

Peak Max and Min

When measuring voltage and current, press the **PEAK** button to activate peak capture. The **PMAX** icon will appear and the display will show the measured signal's positive peak. Press **PEAK** again to step to **PMIN**, the display will show the negative peak. Press **PEAK** to exit.

Low Pass Filter (LPF)

To introduce a low pass filter when measuring AC voltage, long press the **LPF** button. Long press again to exit. Use this feature when measuring variable frequency drive (VFD) equipment.

Low Impedance Mode (LoZ)

If ghost voltages are a concern, select the **LoZ** switch position when measuring voltage, to lower the input impedance to approximately 3 k Ω .

DC Current Zero (Offset)

In DC current mode (with no conductor in the jaw), long press the **ZERO** button until the beeper sounds. The display will zero. The offset value is now stored and removed from subsequent measurements. Long press **ZERO** to exit.

Inrush AC Current

Capture inrush when measuring AC current. Long press the **INRUSH** button with the circuit under test unpowered, INRUSH will appear on the display. Switch power on to the circuit under test and view the inrush current on the display. Long press **INRUSH** to exit.

MEASURING CURRENT WITH THE CLAMP



WARNING

Disconnect the test leads before making clamp measurements.

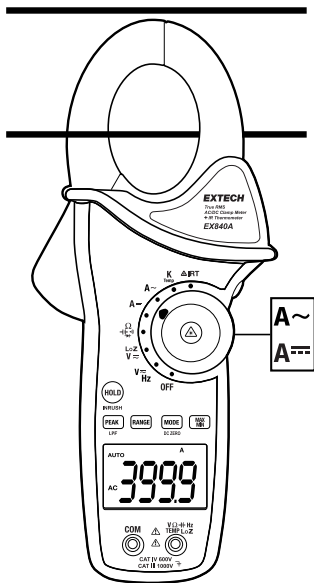

1. Rotate the function switch to the **A AC** or **DC** position.
2. Press the trigger to open jaw. Fully enclose only **one** conductor.
3. Read the current value on the display.

MEASURING VOLTAGE, FREQUENCY, RESISTANCE, DIODE, CAPACITANCE

These measurements are made with the test leads placed 'across' the device or circuit under test (in parallel).



WARNING

Risk of electrocution. High-voltage AC/DC circuits are extremely dangerous and should be measured with great care.

Do not measure resistance, diode, or capacitance on powered devices.

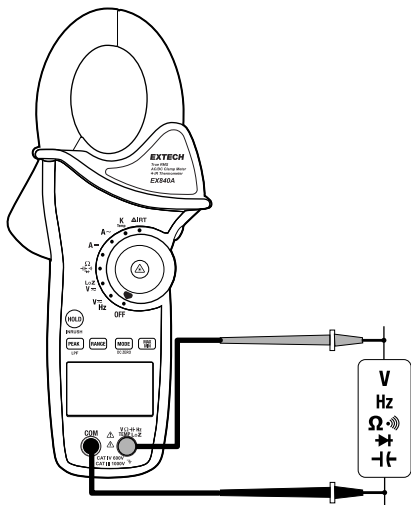

1. Rotate the function switch to the desired function. Press **MODE** to select the desired mode.
2. Insert the black test lead plug into the negative **COM** jack. Insert the red test lead plug into the positive jack.
3. Touch the black test probe tip to the negative side of the circuit. Touch the red test probe tip to the positive side.
4. Read the measurement on the display.

IR TEMPERATURE MEASUREMENTS



CAUTION

Do not directly view or point the laser at an eye.

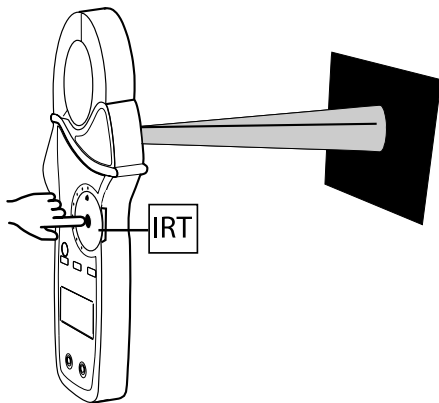

1. Set the function switch to the **IRT** position.
2. Press and hold the laser button and aim the laser pointer toward a surface.
3. With the **IRT** button still depressed, long press **MODE** to toggle °F and °C.
4. Read the temperature measurement on the display. Note that the distance-to-spot ratio is 8:1 for this meter, for example the measured spot is 1 in. in diameter at a distance of 8 in.

TYPE K TEMPERATURE MEASUREMENTS



CAUTION

The supplied thermocouple is rated for 482°F (250°C) maximum.

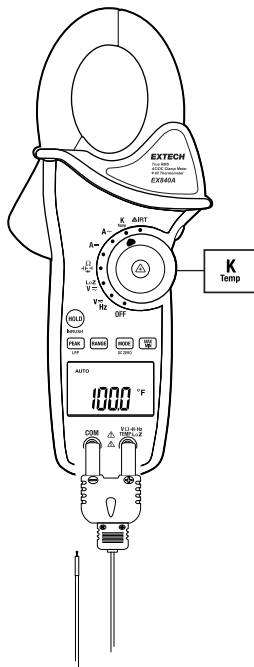

1. Rotate the function switch to the **K TEMP** position. Press **MODE** to select °F or °C.
2. Insert the temperature probe into the test lead jacks, observing correct polarity.
3. Touch the probe tip to the surface under test. Read the temperature measurement on the display.

BASIC SPECIFICATIONS

For complete specifications, please download the user manual.

Display	Backlit LCD with multifunction indicators
Over-range indication	OL display
Battery power	9 V battery
Operating temperature	32 to 122°F (0 to 50°C)
Operating humidity	80% RH max. up to 87°F (31°C)
Dimensions	10.6 x 4.3 x 2.0 in. (270 x 110 x 50 mm)
Weight	14 oz. (396 g)
Safety	Meter: Over-voltage CAT IV 600 V, CAT III 1000 V; Pollution Degree 2 Supplied test leads: Over-voltage CAT IV 600 V, CAT III 1000 V
Agency approvals	ETL, CE, UKCA
Input impedance	> 10 M Ω (Voltage AC/DC); 3 k Ω approx. in LoZ mode
AC bandwidth	50 Hz to 1 kHz (AC voltage); 50/60 Hz (AC current)
AC response	True RMS (AC voltage/current)
Peak detector	> 1 ms
Supplied Thermocouple	Type K; rated 482°F (250°C) maximum

CUSTOMER SUPPORT

Customer Support Local Telephone List:

<https://support.flir.com/contact>

Returns (RMA):

<https://customer.flir.com/Home>

WARRANTY

Teledyne FLIR warrants this Extech brand instrument to be free of defects in parts and workmanship for two years from date of shipment. To view the full warranty text, please visit the support site, link below.

<https://www.flir.com/support-center/warranty/>

Website

<http://www.flir.com>

Customer support

<http://support.flir.com>

Copyright

© 2024, FLIR Systems, Inc. All rights reserved worldwide.

Disclaimer

Specifications subject to change without further notice. Models and accessories subject to regional market considerations. License procedures may apply. Products described herein may be subject to US Export Regulations. Please refer to exportquestions@flir.com with any questions.

Publ. No.: NAS100187
Release: AE
Commit: 96736
Head: 98047
Language: en-US
Modified: 2024-03-29
Formatted: 2024-05-20

