

Gate Valve

## ECOLINE GTF 150-600

Class 150-600  
NPS ½"-2"  
Forged Steel  
Bolted Bonnet  
Flanged Ends

### Type Series Booklet



## **Legal information/Copyright**

Type Series Booklet ECOLINE GTF 150-600

All rights reserved. The contents provided herein must neither be distributed, copied, reproduced, edited or processed for any other purpose, nor otherwise transmitted, published or made available to a third party without the manufacturer's express written consent.

Subject to technical modification without prior notice.

© 12.07.2013

## Gate Valves

### Gate Valves with Bolted Bonnet

## ECOLINE GTF 150-600



#### Main applications

- Boiler feed applications
- Petrochemical industry
- Pipelines and tank farms
- Refineries
- Process engineering

#### Fluids handled

- Steam
- Fluids containing gas
- Gas
- High-temperature hot water
- Feed water

#### Operating data

Operating properties

Characteristic	Value
Nominal pressure	Class 150 - 600
Nominal size	NPS ½" - 2"
Max. permissible pressure	104 bar / 1480 PSI
Max. permissible temperature	816 °C / 1500 °F

Selection as per pressure/temperature ratings (⇒ Page 5)

#### Body materials

Overview of available materials

Material	Temperature limit
ASTM A 105	Up to 427 °C / 800 °F
ASTM A 182 F11	Up to 593 °C / 1100 °F

Material	Temperature limit
ASTM A 182 F22	Up to 593 °C / 1100 °F
ASTM A 182 F304	Up to 816 °C / 1500 °F
ASTM A 182 F316	Up to 816 °C / 1500 °F
ASTM A 182 F304L	Up to 427 °C / 800 °F
ASTM A 182 F316L	Up to 450 °C / 850 °F

Other materials on request.

#### Design details

##### Design

- Gate valve to API 602
- Tested to API 598
- Body made of forged steel
- Bolted bonnet
- Outside screw
- Outside yoke
- Non-rotating stem
- Stem sealed by gland packing
- Non-rising handwheel
- Reduced bore
- Two-piece self-aligning gland follower
- Graphite gland packing
- Stem with burnished shank
- Fully confined bonnet gasket
- Back seat
- Solid wedge
- The valves satisfy the safety requirements of Annex I of the European Pressure Equipment Directive 97/23/EC (PED) for fluids in Groups 1 and 2.
- The valves do not have a potential internal source of ignition and can be used in potentially explosive atmospheres, Group II, category 2 (zones 1+21) and category 3 (zones 2+22) to ATEX 94/9/EC.

#### Variants

- Seal-welded body/bonnet joint
- Full bore
- Hard-faced back seat
- Extended bonnet
- Locking device
- Position indicator
- Electric actuators
- Butt weld ends
- NACE standard
- Other flanged end designs or butt weld ends to ASME B16.25
- Other trims

#### Product benefits

Long gland life and high functional reliability

- Stem with shank burnished to a surface finish of 0.2 µm for reduced friction, lower actuating torque and improved sealing to atmosphere.

- Packing end rings enable higher compressive force by gland follower and prevent extrusion of middle graphite packing rings.
- Two-piece self-aligning gland follower prevents distortion on stem surface caused by improper assembly.

**Reliable sealing and longer service life**

- Hard-faced body seat and solid wedge seat made of wear-resistant and corrosion-proof materials for handling all kinds of corrosive and erosive fluids.
- Male/female joint between body and bonnet prevents excessive compression of fully confined gasket, resulting in longer gasket life and improved sealing performance.

**Additional safety and blow-out protection**

- Standard metal back seat prevents blow-out of stem and other internal components from the valve body and bonnet as a result of fluid pressure inside the valve body.

**Versatile application**

- Stem nut made of chrome nickel steel is suitable for numerous applications, particularly fluids which must not come into contact with component materials containing copper.

**Extended maintenance-free service life**

- Wear allowance higher than specified in relevant standard, for substantially increased service life.
- Hard-facing applied to wedge and seat rings by deposit welding provides extra wear allowance and ensures reliable long-term sealing even with frequent opening/closing cycles.

**Related documents**

- Gate valve, type ECOLINE GTF 800, see type series booklet 7361.12
- Operating manual 7361.81

**On all enquiries/orders please specify**

- Type
- Class
- Nominal size
- Pressure rating
- Temperature rating
- Differential pressure
- Fluid handled
- Material
- Trim material (API trim number)
- Line connection
- Reduced or full bore
- Variants
- Number of type series booklet

**Pressure/temperature ratings**

Permissible operating pressures in bar at a temperature of °C (to ASME B16.34)

Class	Material	0 to 38	93	149	204	260	316	343	371	399	427	454	482	510	538	566	593	621	649	677	704	732	760	788	816
150	A 105	19,7	17,9	15,9	13,8	11,7	9,7	8,6	7,6	6,6	5,5														
300		51,0	46,9	45,2	43,8	41,7	39,3	37,9	36,5	34,8	28,3														
600		102,0	93,8	90,3	87,2	83,1	78,3	75,8	73,1	70,0	56,9														
150	A 182 F11 1)	20,0	17,9	15,9	13,8	11,7	9,7	8,6	7,6	6,6	5,5	4,5	3,4	2,4	1,4	1,4 2)	1,4 2)								
300		51,7	51,7	49,6	47,9	45,9	41,7	40,7	39,3	36,5	35,2	33,4	31,0	22,1	14,8	10,0	6,6								
600		103,4	103,4	99,6	95,5	91,7	83,4	81,0	78,3	73,4	70,0	67,2	62,1	44,1	29,6	20,0	13,1								
150	A 182 F304 3)	19,0	15,9	14,1	13,1	11,7	9,7	8,6	7,6	6,6	5,5	4,5	3,4	2,4	1,4	1,4 2)	1,4 2)	1,4 2)	1,4 2)	1,4 2)	1,4 2)	1,4 2)	1,4 2)	1,4 2)	1,0 2)
300		49,6	41,4	37,2	34,1	32,1	30,3	29,6	29,0	28,6	27,9	27,2	26,9	26,2	24,5	22,4	17,6	14,1	11,4	9,3	7,9	6,6	5,2	4,1	2,8
600		99,3	85,5	77,2	70,7	65,8	62,1	61,0	60,0	59,0	58,3	57,6	57,2	53,4	50,0	44,8	35,5	28,3	22,8	18,3	15,5	12,8	10,3	7,9	5,9
150	A 182 F22	20,0	17,9	15,9	13,8	11,7	9,7	8,6	7,6	6,6	5,5	4,5	3,4	2,4	1,4	1,4 2)	1,4 2)								
300		51,7	51,7	50,3	48,6	45,9	41,7	40,7	39,3	36,5	35,2	33,4	31,0	26,5	18,3	12,1	7,6								
600		103,4	103,4	100,3	97,2	91,7	83,4	81,0	78,3	73,4	70,0	67,2	62,1	52,1	36,9	24,1	15,2								
150	A 182 F316 3)	19,0	16,2	14,8	13,4	11,7	9,7	8,6	7,6	6,6	5,5	4,5	3,4	2,4	1,4	1,4 2)	1,4 2)	1,4 2)	1,4 2)	1,4 2)	1,4 2)	1,4 2)	1,4 2)	1,4 2)	1,0 2)
300		49,6	42,7	38,6	35,5	33,1	31,0	30,3	30,0	29,3	29,0	29,0	28,6	26,5	25,2	24,8	21,0	16,2	12,8	10,0	7,9	6,6	5,2	4,1	2,8
600		99,3	85,5	77,2	70,7	65,8	62,1	61,0	60,0	59,0	58,3	57,6	57,2	53,4	50,0	49,6	42,1	32,8	25,5	20,3	16,2	13,1	10,3	7,9	5,9
150	A 182 F304L	15,9	13,4	12,1	11,0	10,3	9,7	8,6	7,6	7,6	5,5														
300		41,4	35,2	31,4	30,0	27,2	25,5	25,2	24,8	24,5	23,8														
600		82,7	70,3	62,7	57,9	54,1	51,4	50,3	49,6	48,6	47,6														
150	A 182 F316L	15,9	13,4	12,1	11,0	10,3	9,7	8,6	7,6	7,6	5,5	4,5													
300		41,4	35,2	31,4	29,0	27,2	25,5	25,2	24,8	24,5	23,8	23,4													
600		82,7	70,3	62,7	57,9	54,1	51,4	50,3	49,6	48,6	47,6	46,5													

Permissible operating pressures in PSI at a temperature of °F (to ASME B16.34)

Class	Material	32 to 100	200	300	400	500	600	650	700	750	800	850	900	950	1000	1050	1100	1150	1200	1250	1300	1350	1400	1450	1500
150	A 105	285	260	230	200	170	140	125	110	95	80														
300		740	680	655	635	605	570	550	530	505	410														
600		1480	1360	1310	1265	1205	1135	1100	1060	1015	825														
150	A 182 F11 1)	290	260	230	200	170	140	125	110	95	80	65	50	35	20	20 2)	20 2)								
300		750	750	720	695	665	605	590	570	530	510	485	450	320	215	145	95								
600		1500	1500	1445	1385	1330	1210	1175	1135	1065	1015	975	900	640	430	290	190								
150	A 182 F304 3)	275	230	205	190	170	140	125	110	95	80	65	50	35	20	20 2)	20 2)	20 2)	20 2)	20 2)	20 2)	20 2)	20 2)	20 2)	15 2)
300		720	600	540	495	465	440	430	420	415	405	395	390	380	355	325	255	205	165	135	115	95	75	60	40
600		1440	1200	1075	995	930	885	865	845	825	810	790	780	765	710	650	515	410	330	265	225	185	150	115	85
150	A 182 F22	290	260	230	200	170	140	125	110	95	80	65	50	35	20	20 2)	20 2)								
300		750	750	730	705	665	605	590	570	530	510	485	450	385	265	175	110								
600		1500	1500	1455	1410	1330	1210	1175	1135	1065	1015	975	900	755	535	350	220								
150	A 182 F316 3)	275	235	215	195	170	140	125	110	95	80	65	50	35	20	20 2)	20 2)	20 2)	20 2)	20 2)	20 2)	20 2)	20 2)	20 2)	15 2)
300		720	620	560	515	480	450	440	435	425	420	420	415	385	365	360	305	235	185	145	115	95	75	60	40
600		1440	1240	1120	1025	955	900	885	870	855	845	835	830	775	725	720	610	475	370	295	235	190	150	115	85
150	A 182 F304L	230	195	175	160	150	140	125	110	110	80														
300		600	510	455	420	395	370	365	360	355	345														
600		1200	1020	910	840	785	745	730	720	705	690														
150	A 182 F316L	230	195	175	160	150	140	125	110	110	80	65													
300		600	510	455	420	395	370	365	360	355	345	340													
600		1200	1020	910	840	785	745	730	720	705	690	675													

**Test pressures**

Test	Test medium	Class 150		Class 300		Class 600	
		bar	psi	bar	psi	bar	psi
Shell	Water	31,0	450	77,6	1125	153,4	2225
Leak test (back seat)		22,4	325	56,9	825	113,8	1650
Leak test (seat)		22,4	325	56,9	825	113,8	1650
Leak test (seat)	Air	5,5	80	5,5	80	5,5	80

- 1) Use normalised and tempered materials only.
- 2) Flanged end ratings terminate at 538 °C (1000 °F).
- 3) At temperatures over 538 °C (1000 °F), use only when carbon content is 0.04% or higher.

**Materials**

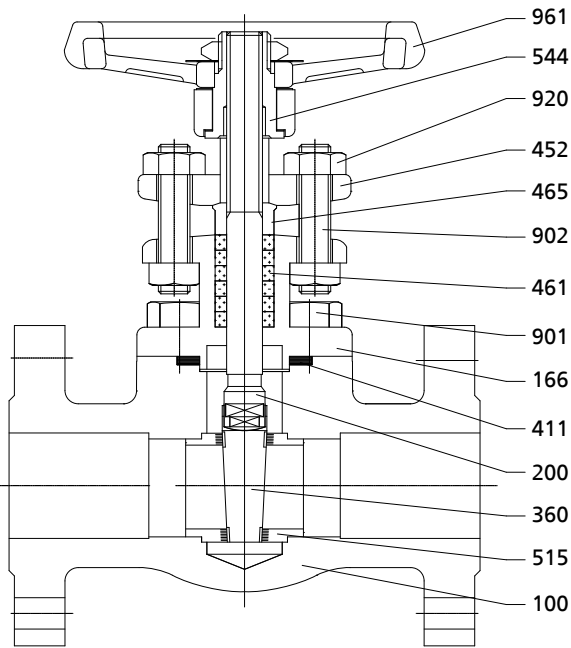

Overview of available materials

Part No.	Description	Material				
		A 105 Trim 8	A 182 F11 Trim 5	A 182 F22 Trim 5	A 182 F304 Trim 2	A 182 F316 Trim 10
100	Body	A 105	A 182 F11	A 182 F22	A 182 F304	A 182 F316
166	Yoke	A 105	A 182 F11	A 182 F22	A 182 F304	A 182 F316
200	Stem	A 182 F6a	A 182 F6a	A 182 F6a	A 182 F304	A 182 F316
360	Wedge	A 182 F6a	A 182 F6a + STL6	A 182 F6a + STL6	A 182 F304	A 182 F316
411	Joint ring	304 + graphite	304 + graphite	304 + graphite	304 + graphite	316 + graphite
452	Gland follower	A 105	A 105	A 105	A 182 F304	A 182 F316
465	Lower gland section	A 276 410	A 276 410	A 276 410	A 276 304	A 276 316
461	Gland packing	Flexible graphite	Flexible graphite	Flexible graphite	Flexible graphite	Flexible graphite
515	Seat ring	A 276 410 + STL6	A 276 410 + STL6	A 276 410 + STL6	A 276 304	A 276 316
544	Threaded bush	A 276 410	A 276 410	A 276 410	A 276 410	A 276 410
901	Bolt	A 193 B7	A 193 B16	A 193 B16	A 193 B8	A 193 B8M
902	Stud	A 193 B8	A 193 B16	A 193 B16	A 193 B8	A 193 B8
920	Nut	A 194 2H	A 194 8	A 194 8	A 194 8	A 194 8M
961	Handwheel	A 197	A 197	A 197	A 197	A 197

**Dimensions**

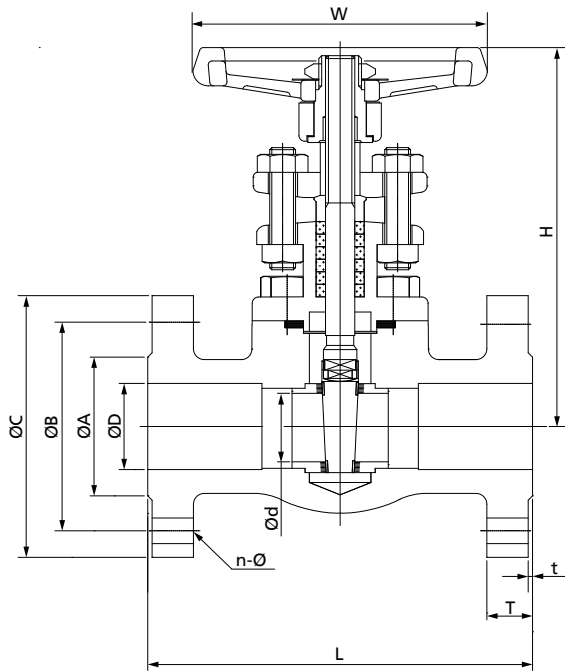

Dimensions in mm

Class	NPS	L	T	t	n-Ø	Ød	ØD	ØA	ØB	ØC	H <sup>4)</sup>	W	[kg]
150	½"	108	11,5	1,6	4-16	9,5	15	35	60,5	89	132	100	2,58
	¾"	117	13,0	1,6	4-16	12,7	20	43	70,0	98	137	100	3,10
	1"	127	14,5	1,6	4-16	17,5	25	51	79,5	108	157	120	4,80
	1 ½"	165	17,5	1,6	4-16	28,6	40	73	98,5	127	212	150	10,31
	2"	178	19,5	1,6	4-19	36,5	50	92	120,5	152	224	180	13,43
300	½"	140	14,5	1,6	4-16	9,5	15	35	66,5	95	132	100	3,52
	¾"	152	16,0	1,6	4-19	12,7	20	43	82,5	118	137	100	4,44
	1"	165	17,5	1,6	4-19	17,5	25	51	89,0	124	157	120	5,96
	1 ½"	190	21,0	1,6	4-22	28,6	40	73	114,5	156	212	150	12,78
	2"	216	22,5	1,6	8-19	36,5	50	92	127,0	165	224	180	15,03
600	½"	165	20,7	6,4	4-16	9,5	15	35	66,5	95	132	100	3,25
	¾"	190	22,3	6,4	4-19	12,7	20	43	82,5	118	137	100	5,15
	1"	216	23,9	6,4	4-19	17,5	25	51	89,0	124	157	120	6,50
	1 ½"	241	28,7	6,4	4-22	28,6	40	73	114,5	156	212	150	13,77
	2"	292	31,8	6,4	8-19	36,5	50	92	127,0	165	224	180	17,03

**Mating dimensions - Standards**

Face-to-face lengths: ASME B16.10  
Flanges: ASME B16.5

**Notes on installation**

Flow may pass a gate valve in either direction. High-pressure valves with pressure relief arrangement are unidirectional, however.

4) Open



**KSB Valves (Changzhou) Co., Ltd.**

No. 68 Huanbao Four Road, Environment Protection Industrial Park, Xinbei District, Changzhou (China)

Tel. +86 21 6430 8030 • Fax +86 519 8168 5855 • [www.ksb.com](http://www.ksb.com)

12.07.2013

7361.11/01-EN