



Special Function Dial Gages

This section includes special function dial gages that we list as regular items. Gages are also available with electronic indicators on request, where noted.

- ◆ Chamfer Gages
- ◆ Countersink Gages
- ◆ Hole Gages
- ◆ Bore Gages – See Bore Gages Section
- ◆ Direct-Reading Thickness Gages
- ◆ Snap Gages
- ◆ Groove Gages
- ◆ Caliper Gages
- ◆ Depth Gages
- ◆ Out-of-roundness Gages
- ◆ Inside Dial Gages
- ◆ Automotive Gages
- ◆ Crankshaft Distortion Gages
- ◆ Cylinder Gages
- ◆ Disc Brake Gages
- ◆ Large Diameter Gages

In addition, we have made many other special function gages to suit a wide variety of our customers' specific requirements. If you have a special application, we invite you to submit your drawings and specifications to our Special Order Department at 121 Crescent Street, Athol, MA 01331, USA. We will be happy to provide a prompt quotation.

Chamfer Gages

For Internal Chamfers:
No. 683 Series 0-90°
No. 684 Series 90-127°

For External Chamfers:
No. 685 Series 0-90°
No. 686 Series 90-127°

These gages directly measure the diameter of chamfered holes. No setting master is necessary. When the three-blade plunger is pressed against a flat surface, the gage should read the set number stamped on the back of the indicator. In case of wear, the gage may be adjusted to read the proper number.

All ground surfaces are of hardened tool steel. Indicators are AGD design.

Internal gages will measure the largest diameter of any chamfer that has an included angle within the range of angles printed on the dial face of the gage.

External gages will measure the smallest diameter of any chamfer within the range of angles printed on the dial face of the gage.



Left, No. 683-1Z;
 Right, No. 685-3Z.

Right: No. 684-2Z Chamfer Gage with No. F2710-3 Electronic Indicator on the No. 695 Check Stand.

See specifications on next page.



Chamfer Gages (continued)

Internal Gages

Inch Reading

Range	0-90° Angle		90-127° Angle	
	Catalog No.	EDP No.	Catalog No.	EDP No.
0-3/8"	683-1Z	63684	684-1Z	63688
0-1/2"	683-2Z	63685	684-2Z	63689
0-1"	683-3Z	63686	684-3Z	63690
1-2"	683-4Z	63687	684-4Z	63691

Millimeter Reading with Yellow Dials

0-9.5mm	683M-1Z	64989	684M-1Z	64993
0-12.7mm	683M-2Z	64990	684M-2Z	64994
0-25mm	683M-3Z	64991	684M-3Z	64995
25-50mm	683M-4Z	64992	684M-4Z	64996

External Gages

Inch Reading

1/8-1/2"	685-1Z	63692	686-1Z	63695
3/16-1"	685-2Z	63693	686-2Z	63696
1-2"	685-3Z	63694	686-3Z	63697

Millimeter Reading with Yellow Dials

3.2-12.7mm	685M-1Z	64997	686M-1Z	65000
4.7-25mm	685M-2Z	64998	686M-2Z	65001
25-50mm	685M-3Z	64999	686M-3Z	65002

Check Gage Stand for Chamfer, Countersink and Hole Gages

Description	Catalog No.	EDP No.
8 3/16" H x 6" W x 4" D (212 x 150 x 100mm) Hold Downs – 5" (125mm) on Center – 1/4" (6.3mm) Holes	695	63875

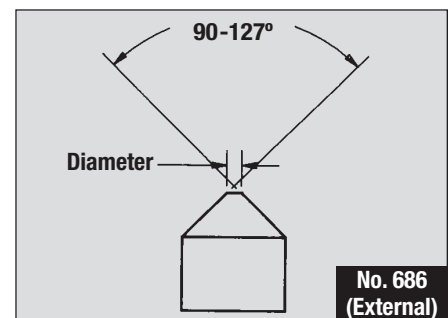
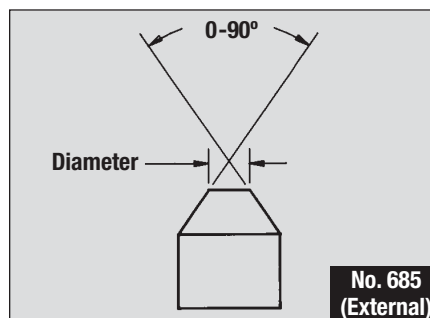
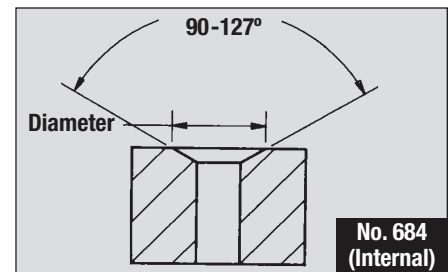
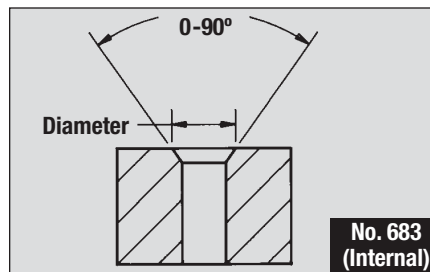

NOTE: Also available with electronic indicators.
Please specify.

Gages furnished in deluxe padded case.