



Dial Depth Gauges

- Internal caliper gauge to measure internal diameter of cylindrical workpiece and recessed groove diameter. It can measure groove diameter of "O" ring by modifying spare contact point.
- Set dimension within $\pm 1\text{mm}$ (indication range 2mm) can be comparatively measured (880 series) by alternatively using auxiliary spare contact point in accordance with measured dimension.

- Please set standard dimension within measuring range with micrometer or ring gauge.

IM-880

Maximum Measuring Depth 70mm
Graduation 0.01mm
Measuring Range 20~35mm

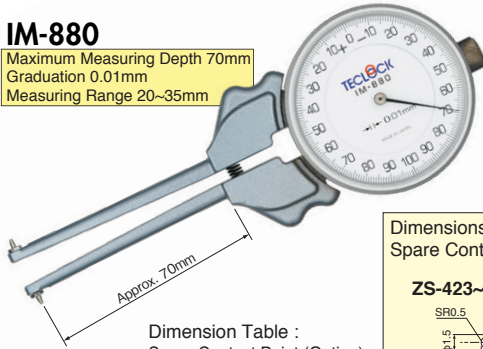

Dimension Table : Spare Contact Point (Option)

Code No.	L1	L2	Measuring Range
ZS-423	2.5	4	20~23
ZS-424	3.5	5	22~25
ZS-425	4.5	6	24~27
ZS-426	5.5	7	26~29
ZS-427	5.5	8	28~31
ZS-428	5.5	9	30~33
ZS-429	5.5	10	32~35

unit : mm

Dimensions : Spare Contact Point (Option)

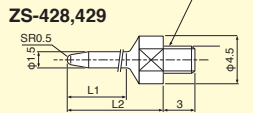
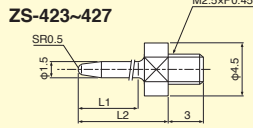

unit : mm

IM-881

Maximum Measuring Depth 75mm
Graduation 0.01mm
Measuring Range 30~62mm

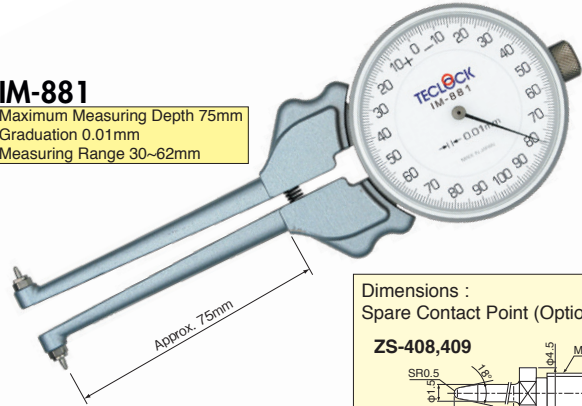

Dimension Table : Spare Contact Point (Option)

Code No.	L1	L2	Measuring Range
ZS-408	3	4.5	30~38
ZS-409	5.5	7.5	36~44
ZS-410	6	10.5	42~50
ZS-411	6	13.5	48~56
ZS-412	6	16.5	54~62

unit : mm

Dimensions : Spare Contact Point (Option)

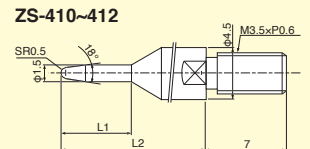
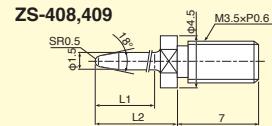

unit : mm

IM-882

Maximum Measuring Depth 90mm
Graduation 0.01mm
Measuring Range 55~153mm

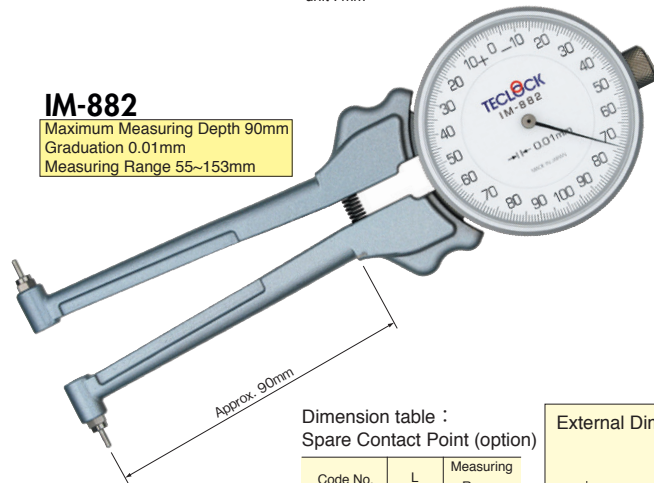

Dimension table : Spare Contact Point (option)

Code No.	L	Measuring Range
ZS-413	7	55~73
ZS-414	15	71~89
ZS-415	23	87~105
ZS-416	31	103~121
ZS-417	39	119~137
ZS-418	47	135~153

unit : mm

Dimensions : Spare Contact Point (Option)

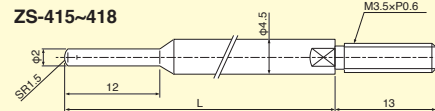
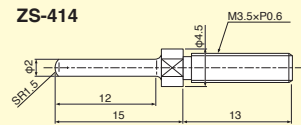
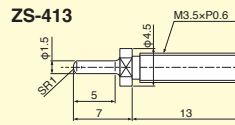

unit : mm

External Dimensions

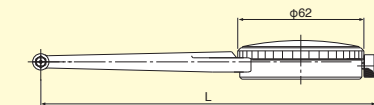

Model	L
IM-880	165
IM-881	170
IM-882	183

Dimensions

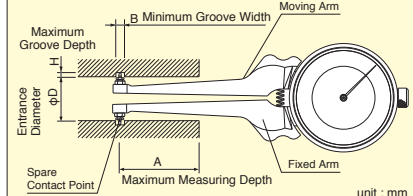

Specifications

Model	Graduation (mm)	Measuring Range (mm)	Indicating Range (mm)	Indication Error (μm)	Measuring Force (N)	Weight (g)	Spare Contact Point		Maximum Measuring Depth A (mm)	Entrance Diameter φD (mm)*	Groove Depth H (mm)	Minimum Groove Width B (mm)
							Code No.	Measuring Range (mm)				
IM-880	0.01	20~35	2	± 20	3 or less	196	ZS-423	20~23	70	15-18	2.5	2.5
							ZS-424	22~25				
							ZS-425	24~27				
							ZS-426	26~29				
							ZS-427	28~31				
							ZS-428	30~33				
							ZS-429	32~35				
							ZS-429	32~35				
IM-881	0.01	30~62	2	± 20	3 or less	218	ZS-408	30~38	75	27.4~35.4	4.3	2.5
							ZS-409	36~44				
							ZS-410	42~50				
							ZS-411	48~56				
							ZS-412	54~62				
							ZS-413	55~73				
							ZS-414	71~89				
							ZS-414	71~89				
IM-882	0.01	55~153	2	± 20	3 or less	240	ZS-415	87~105	90	45-63	5	3.5
							ZS-416	103~121				
							ZS-417	119~137				
							ZS-417	119~137				
							ZS-418	135~153				
							ZS-418	135~153				
							ZS-418	135~153				
							ZS-418	135~153				

*φD=Measuring Rang - 2H