

SERIES 325

OUTSIDE MICROMETER WITH INTERCHANGEABLE ANVILS

- ◆ Graduation: 0.01mm
- ◆ Ratchet stop
- ◆ Carbide measuring faces
- ◆ Supplied with setting standards

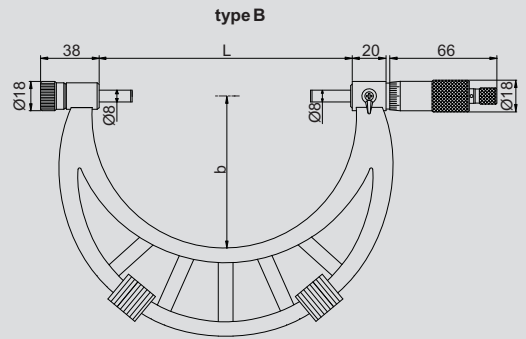
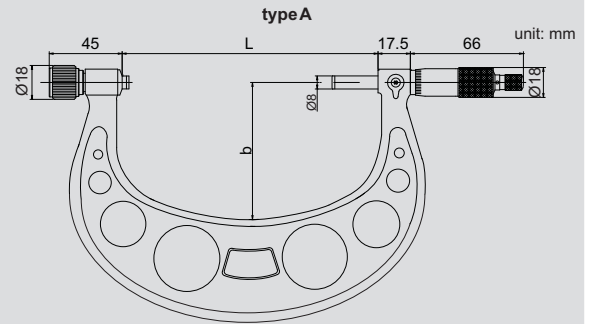
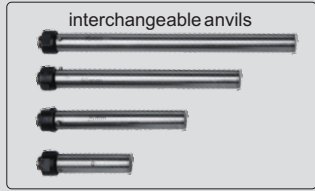

| Code | Range | Type | Accuracy | L | b |
|------------|------------|------|----------|------|-----|
| 325-002-01 | 0-50mm | A | 4μm | 58 | 35 |
| 325-004-01 | 0-100mm | A | 5μm | 108 | 57 |
| 325-006-01 | 0-150mm | A | 6μm | 158 | 82 |
| 325-008-01 | 100-200mm | A | 7μm | 208 | 114 |
| 325-012-01 | 150-300mm | A | 9μm | 308 | 165 |
| 325-016-02 | 300-400mm | B | 11μm | 409 | 224 |
| 325-020-02 | 400-500mm | B | 13μm | 509 | 275 |
| 325-024-02 | 500-600mm | B | 14μm | 609 | 321 |
| 325-028-02 | 600-700mm | B | 16μm | 709 | 371 |
| 325-032-02 | 700-800mm | B | 18μm | 809 | 426 |
| 325-036-02 | 800-900mm | B | 20μm | 909 | 476 |
| 325-040-02 | 900-1000mm | B | 22μm | 1009 | 576 |

SERIES 351

INSIDE MICROMETER



351-001-01

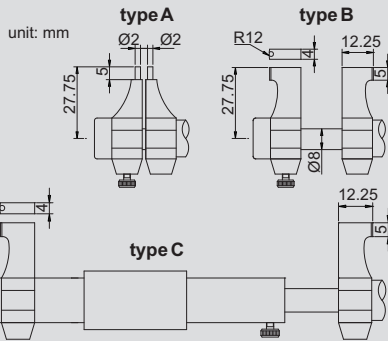

- ◆ Graduation: 0.01mm
- ◆ Carbide measuring faces
- ◆ Ratchet stop

| Code | Range | Anvil | Accuracy | Setting Ring |
|------------|-----------|-------|----------|-----------------|
| 351-001-01 | 5-30mm | A | 5μm | included (5mm) |
| 351-002-01 | 25-50mm | B | 6μm | included (25mm) |
| 351-003-01 | 50-75mm | B | 7μm | optional |
| 351-004-01 | 75-100mm | C | 8μm | optional |
| 351-005-01 | 100-125mm | C | 9μm | optional |
| 351-006-01 | 125-150mm | C | 9μm | optional |

SERIES 352

TUBULAR INSIDE MICROMETER



352-002-01

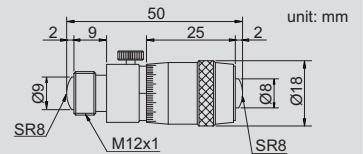

- ◆ Graduation: 0.01mm
- ◆ Travel of micrometer head: 13mm
- ◆ Accuracy: $(3+n+L/50)\mu\text{m}$, n=number of rods, L=max. measuring length
- ◆ Supplied with setting standards
- ◆ Carbide measuring faces

| Code | Range | Extension Rods (mm) |
|------------|-----------|---|
| 352-002-01 | 50-63mm | — |
| 352-006-01 | 50-150mm | 13, 25, 50 |
| 352-012-01 | 50-300mm | 13, 25, 50(2pcs), 100 |
| 352-020-01 | 50-500mm | 13, 25, 50(2pcs), 100, 200 |
| 352-024-01 | 50-600mm | 13, 25, 50, 100, 150, 200 |
| 352-040-01 | 50-1000mm | 13, 25, 50(2pcs), 100, 200(2pcs), 300 |
| 352-060-01 | 50-1500mm | 13, 25, 50(2pcs), 100, 200(3pcs), 300(2pcs) |