

# HEIGHT GAGES

## Digital Counter Type Height Gages Series 192

### Features

- Easy and error-free reading with both up and down digital counters as well as a dial.
- The counters and dial can be zeroed at any scriber position.
- Provided with a feed wheel for easy coarse feeding.
- Carbide-tipped scriber.

192-150  
12"

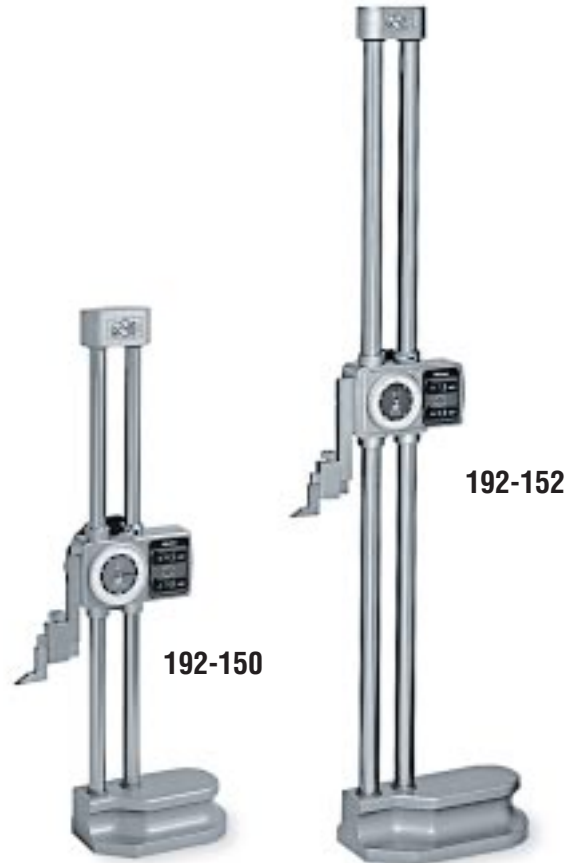

### Specifications

#### Digital Counter Type Height Gage

##### Inch

Order No.	Range	Dial Graduation	Digital Counter Graduation	Accuracy	Mass (lbs)	Standard Accessories
192-150	0–12"	.001"	.1" (Dual Reading)	±.0015"	9.26	
192-151	0–18"	.001"	.1" (Dual Reading)	±.002"	20.28	Scriber (900258)
192-152	0–24"	.001"	.1" (Dual Reading)	±.002"	21.60	Scriber Clamp (901385)
192-153	0–40"	.001"	.1" (Dual Reading)	±.003"	37.5	

##### Metric

Order No.	Range	Dial Graduation	Digital Counter Graduation	Accuracy	Mass (lbs)	Standard Accessories
192-130	0–300mm	0.01mm	1.0mm (Dual Reading)	±0.03mm	9.26	
192-131	0–450mm	0.01mm	1.0mm (Dual Reading)	±0.05mm	20.28	Scriber (07GZA000)
192-132	0–600mm	0.01mm	1.0mm (Dual Reading)	±0.05mm	21.60	Scriber Clamp (07GZA002)
192-133	0–1000mm	0.01mm	1.0mm (Dual Reading)	±0.07mm	37.5	