



TD8620

Handheld Digital TeslaMeter

USER'S MANUAL

Tunkia Co.,Ltd reserves the right to add, improve, modify, or withdraw function ,design modification, or products at any time without notice. Tunkia Co.,Ltd shall not be liable for errors contained herein or for incidental or consequential damages in connection with use of this material.

The Tunkia website, ***WWW.tunkia.com*** contains details of all our products. This site is regularly updated, so check it from time to time to learn about recent development.

Tunkia Co .,Ltd.

16 Panpan Road, Changsha ,Hunan, China

TEL: 86-0731-84930888

FAX: 86-0731-84930990

Email:sales@tunkia.com

Web: <http://www.tunkia.com>

CONTENT

CONTENT.....	1
1. GENERAL DESCRIPTION.....	3
2. SPECIFICATIONS.....	4
2.1. TD8620-5.....	4
2.2. TD8620-2.....	4
2.3. TD8620-1.....	5
3. INTRODUCTION.....	6
4. AXIAL AND TRANSVERSE PROBES.....	9
5. INITIAL SETUP.....	10
5.1. Install Batteries.....	10
5.2. Select probe.....	10
5.3. Connect the Hall probe.....	10
5.4. Turn on apparatus.....	11
5.5. Null Probe.....	11
6. OPERATION.....	12
6.1. Turn on meter.....	12
6.2. Gauss/mT.....	12
6.3. Handling probe.....	12

6.4. Probe operation.....	13
6.5. Hold.....	14
7. IN CASE OF TROUBLE.....	15

1. GENERAL DESCRIPTION

The TD8620 Handheld Digital Teslameter is a field-portable unit that measures DC magnetic fields with direct digital readout in mT or G. The unit is designed for wide range, auto-range, high accuracy, and ease of use .

TD8620 includes three grades of meters

Accuracy of **TD8620-1** is $\pm 1\%$ of reading

Accuracy of **TD8620-2** is $\pm 2\%$ of reading

Accuracy of **TD8620-5** is $\pm 5\%$ of reading

2. SPECIFICATIONS

2.1. TD8620-5

Range	200 mT	2000 mT
Scope	Maximum calibration field 2400 mT, 24 kilogauss	
Resolution	10 μ T	
Accuracy	0~1000 mT: \pm 2% 1000 mT ~ 2400 mT: \pm 5%	
Display	4 digit (in Decimal)	
Power	Stud-snap Battery Operated ;one section of 9 V battery	
Operating environment	0°C ~ 50°C	
Storage temperature	-20°C ~ 50°C	
Dimensions	160 mm \times 80 mm \times 32 mm	
Weight	260 g (include battery and cable)	
Hall probe	Transverse probe , with 1 m cable	

2.2. TD8620-2

Range	200 mT	2000 mT
Scope	Maximum calibration field 2.4 mT, 24 kilogauss	
Resolution	10 μ T	
Accuracy	\pm 2%	
Display	4 digit (in Decimal)	
Power	Stud-snap Battery Operated ;one section of 9 V battery	
Operating environment	0°C ~ 50°C	
Storage temperature	-20°C ~ 50°C	
Dimensions	160 mm \times 80 mm \times 32 mm	
Weight	260 g (include battery and cable)	
Hall probe	Transverse probe , with 1 m cable	

2.3. TD8620-1

Range	200 mT	2000 mT
Scope	Maximum calibration field 2400 mT, 24 kilogauss	
Resolution	10 μ T	
Accuracy	$\pm 1\%$	
Display	4 digit (in Decimal)	
Power	Stud-snap Battery Operated ;one section of 9 V battery	
Operating environment	0°C ~ 50°C	
Storage temperature	-20°C ~ 50°C	
Dimensions	160 mm \times 80 mm \times 32 mm	
Weight	260 g (include battery and cable)	
Hall probe	Transverse probe , with 1 m cable	

3. INTRODUCTION

TD8620 Handheld Digital Teslameter front panel is shown in Fig1.

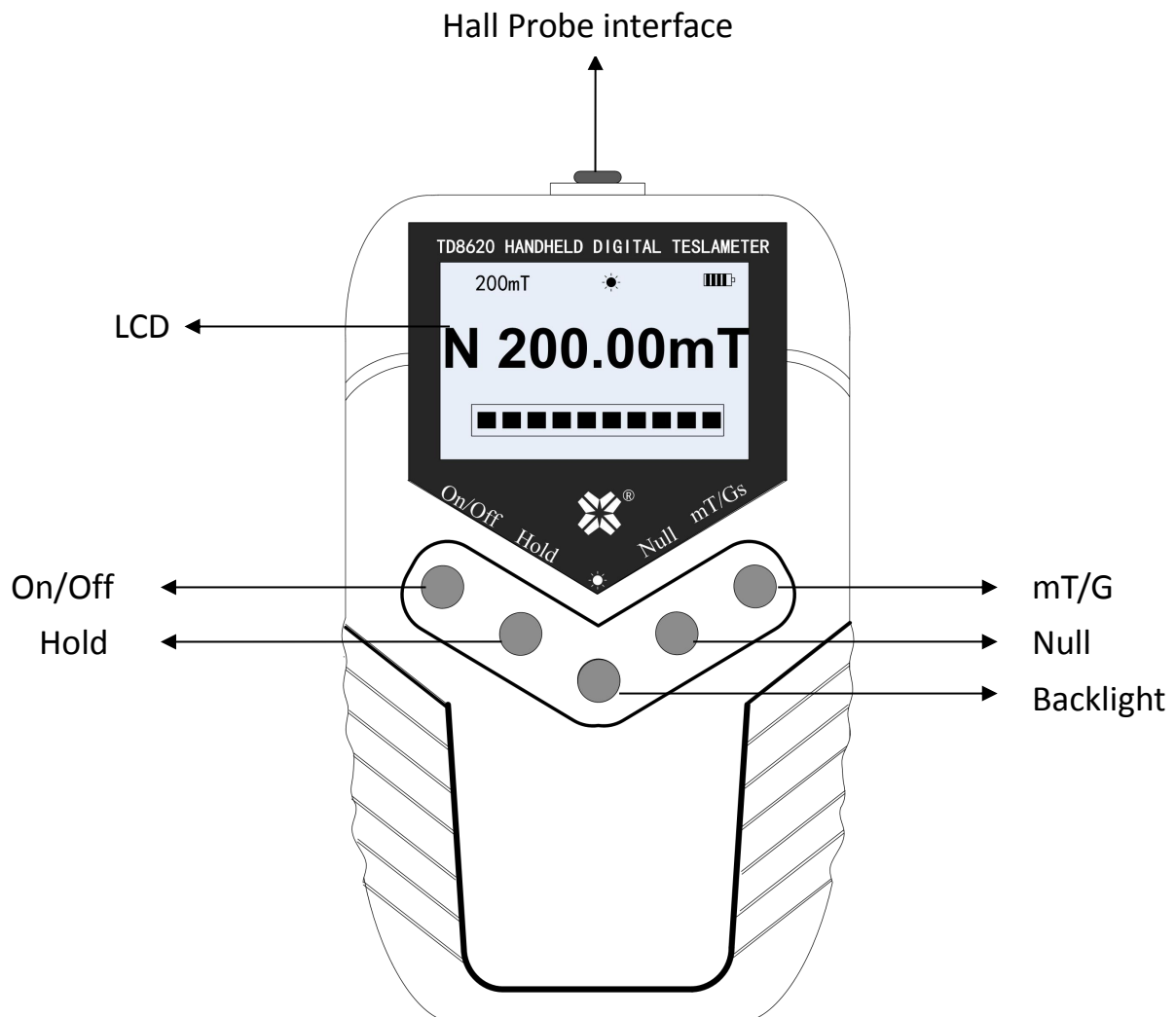



Fig 1 Front Panel

TD 8620 front panel key are defined as follows.

- 1) **ON/OFF**: Turns power to the unit on/off.
- 2) **Hold**: Turn Max Hold feature on and off. Max Hold captures and displays the highest field reading.

- 3) : Turn backlight feature on and off. Backlight lightens up the LCD for reading.
- 4) **NULL**: Used to zero or null effects of ambient low level fields from the probe. When user pushes the NULL key, "0000.0 G or 000.00 mT" displayed. The unit then automatically accepts whatever residual field it reads as a zero offset .
- 5) **mT/G**: Changes units from mT to gauss .Gauss is used in the cgs system :1 G=0.1 mT, mT is used in the SI system :1 mT =10 G

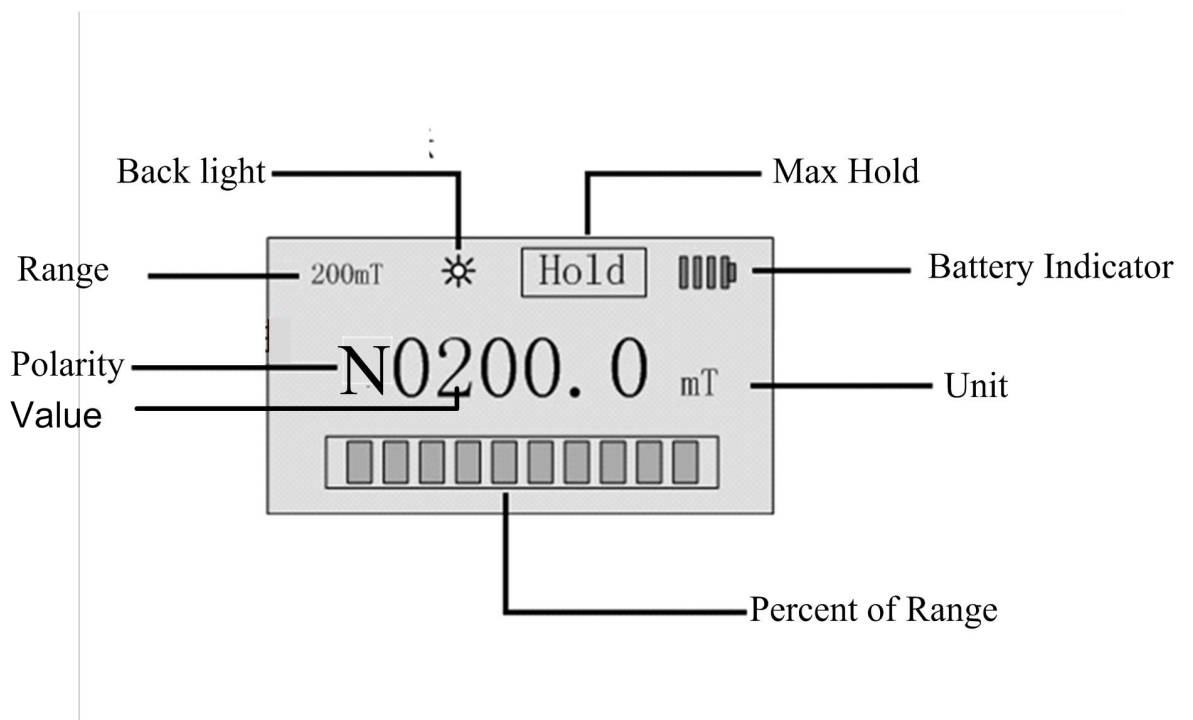

Fig 2 LCD Display

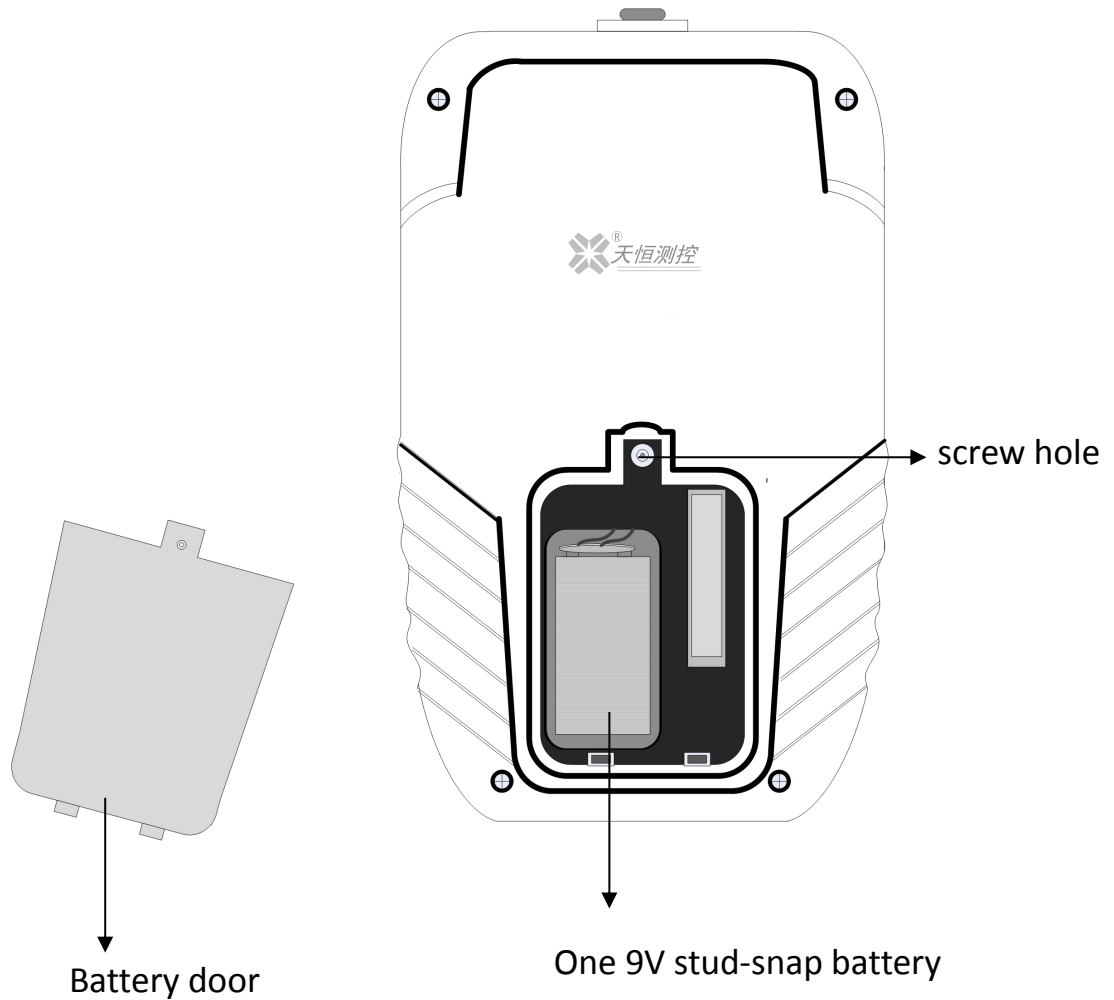

Fig 3 Rear Panel

When the stud-snap battery is used up, you should take the follow steps to replace it. Firstly, use a long-stemmed driver to remove off the screw which on the hole shown in the fig 3. Secondly, unfasten the snap of the battery, then take a new battery replace of the old ,fasten the snap , screw on. Finally replace the battery door.

4. AXIAL AND TRANSVERSE PROBES

TD8620 can use either the axial or transverse probe shown in Fig

4.

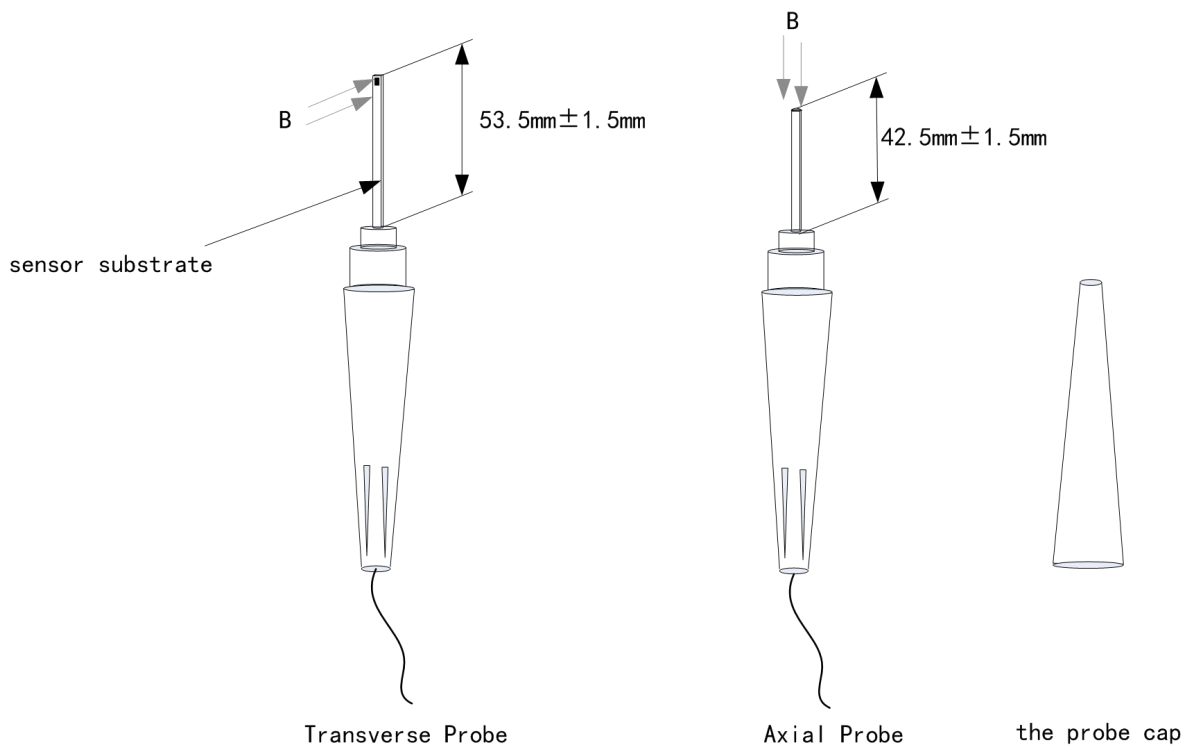

Fig 4 Transverse and axial probe

CAUTION :Care must be taken when handing the probe .The tip of the probe is very fragile .Pressure the Hall sensor can alter its calibration. Don't apply more force than is required to hold probe in place. So there is no excessive pressure which will tend to bend or depress the sensor substrate and will destroy the Hall element inside.

5. INITIAL SETUP

5.1. Install Batteries

When the stud-snap battery is used up, you should take the follow steps to replace it. Secondly, unfasten the snap of the battery, then take a new battery replace of the old ,fasten the snap ,screw on. Finally replace the battery door.

5.2. Select probe

You can select the axial or transverse probe.

5.3. Connect the Hall probe

Plug the probe into the male connector at the top of the teslameter. Make sure that the groove of female connector with the probe and bump of the male connector be matched shown in Fig 5 . However, it is most important that certain precautions be taken when handing and installing probes so that they are not damage or destroyed ,and to preserve their accurate calibration.

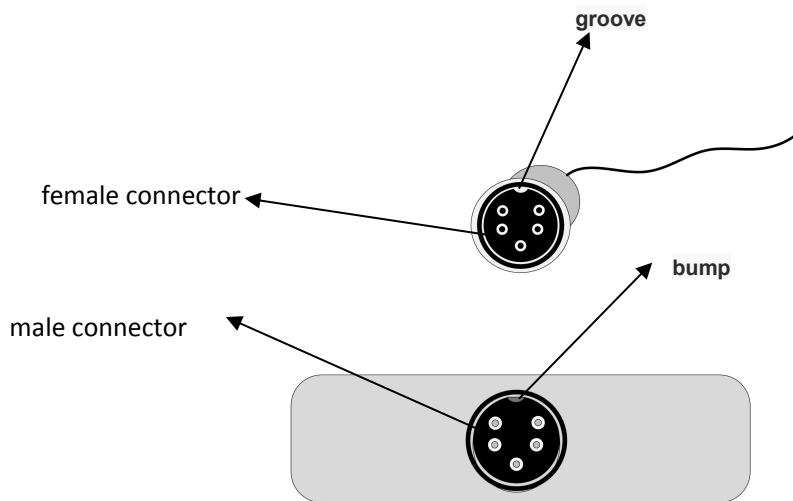

Fig 5 connectors

5.4. Turn on apparatus

Push the **ON/OFF** key on. The LCD displays like Fig 2.

5.5. Null Probe

It is good practice to zero the instrument immediately prior to making critical field measurements. For absolute zeroing, place the probe in a zero-field region, either in a zero field chamber or inside a suitable, magnetic field, so that the probe is shielded from the earth's magnetic field and other stray fields.

If desired, a relative zero setting may be done; the instrument is zeroed after the probe is placed in its measurement position. Thus any ambient field is automatically subtracted from subsequent measurement. The probe should not be moved once zeroing is complete.

6. OPERATION

6.1. Turn on meter

Push the **On/Off** key. The LCD displays parameters as range, polarity, value, unit ,battery indicator, percent of range and so on.

6.2. Gauss/mT

Press the **Gauss/mT** key to toggles the display between the two units.

6.3. Handling probe

The tip of the probe is very fragile. Stressing the Hall sensor alter its calibration. Any excess force can easily break the sensor. Broken sensor are not repairable. The axial sensor is exposed on the end of the probe. A collision with a hard surface can damage the sensor or wear away its protective coating. The transverse sensor is somewhat susceptible to bending stress and erosion of the protective coating.

When the meter is not in use, the probe should be mounted by cover.

6.4. Probe operation

For best results , the instrument and probe should warm up for at least 10 minutes before operation.

When magnetic field forward vertical cross the Hall sensor ,the polarity is positive(N)see Fig 6,or is negative (S)

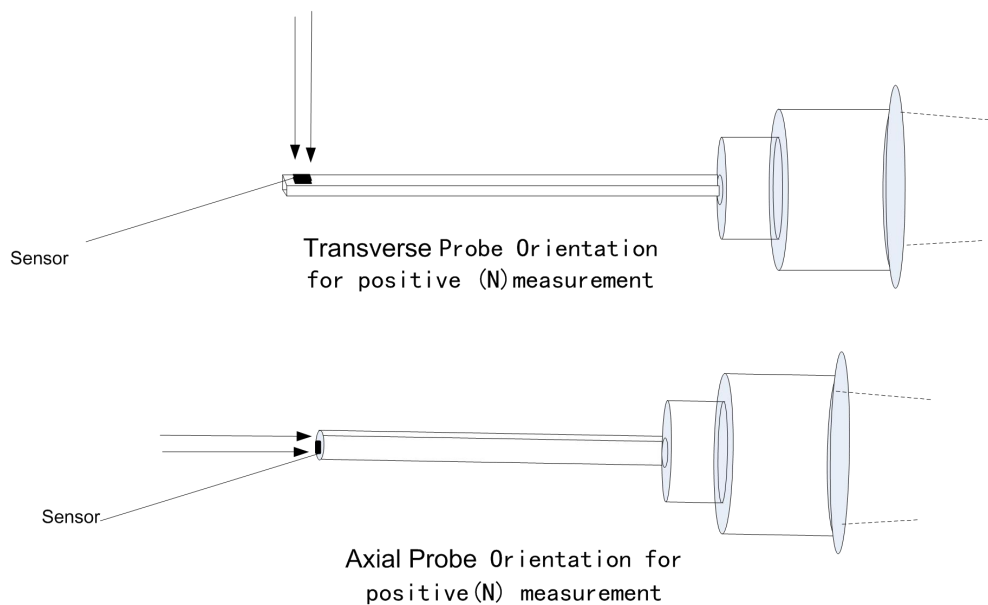

Fig 6 positive(N) measurement

Probe readings are dependent on the angle of the sensor in relation to the magnetic field. The magnetic field should Vertical cross the sensor. Maximum output occurs when the flux vector is perpendicular to the plane of the sensor. The greater the deviation from Vertical orientation ,the larger error of reading.

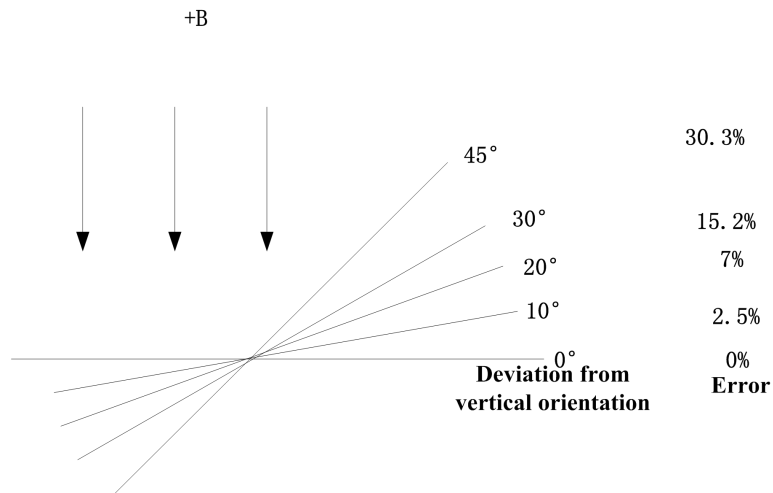

Fig 7 Effect of Angle on Measurement

6.5. Hold

The Hold function display the largest field magnitude measured .When the Hold key is pressed, the maximum value is captured and shown in the display. The “Hold” is displayed in the LCD like in Fig 2. Press the Hold key again, Hold function will be turn off ,the “Hold” is disappear .The meter is real-time measurement of magnetic field.

7. IN CASE OF TROUBLE

1. **Can't turn on the power or automatic shut off.** The solution :check the battery install correctly and the power is sufficient .If not please take the steps like the section "INITIAL SETUP" to change a new battery or fasten the snap.
2. **The LCD can't light up .** Check the female connector of probe and the male connector at the top of TD8620 tighten or connected correctly.