

Model: A15U-1200-6

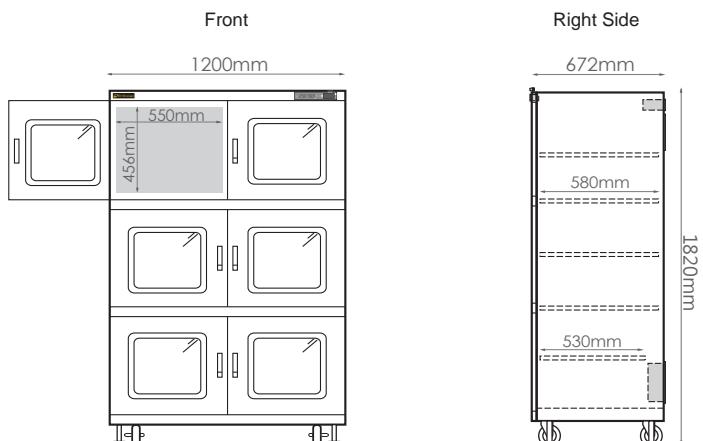

Model: A15U-600

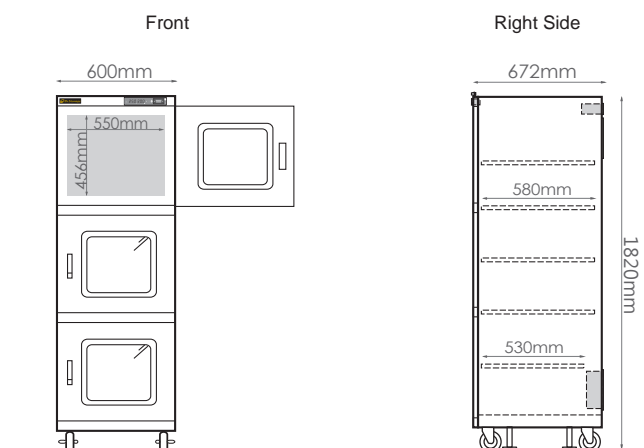

Model: A15U-400

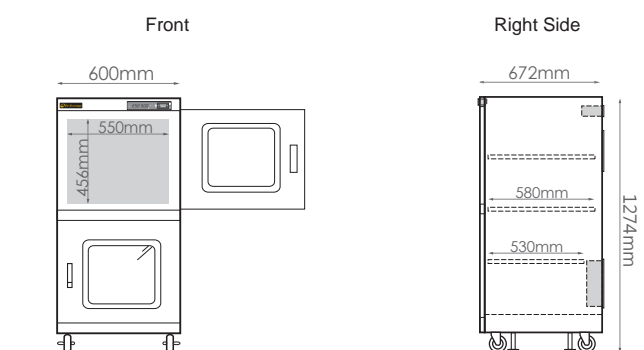

Model: A15U-200

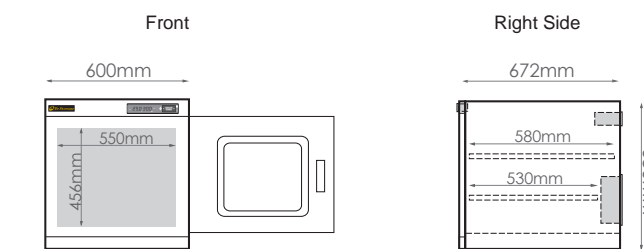

Model: A15U-575

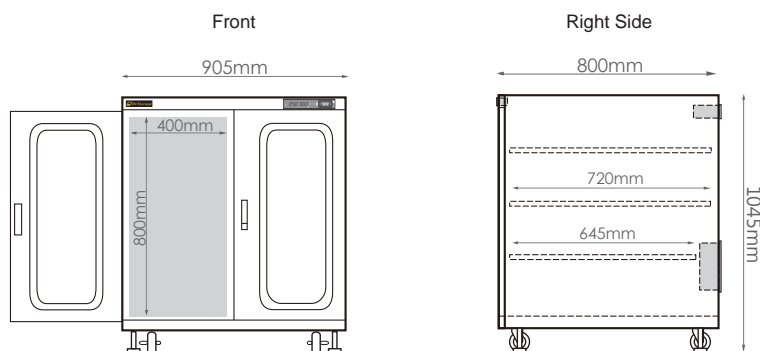

Model: A15U-315

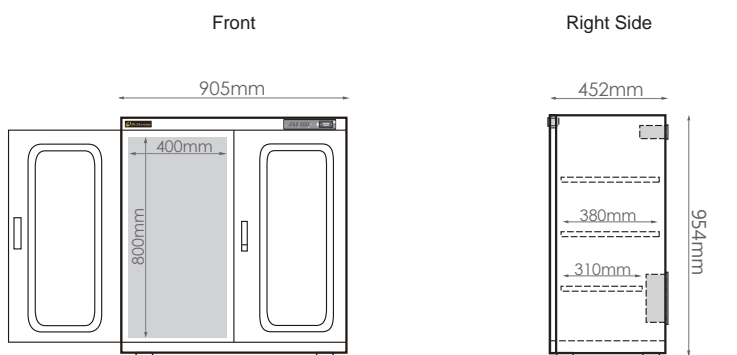

Model: A15U-157

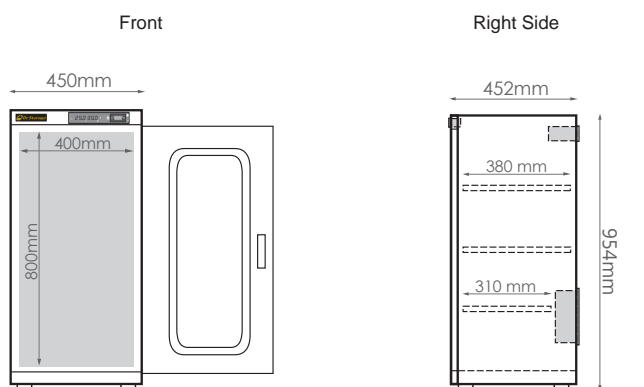

Features



Humidity range : 15~50%RH
(Adjustable)



Bins on the windows for color management
and document management.



Embedded RS-232 port for a data logger
recording and central monitoring system.



UL and CE approved
Comply with IPC/JEDEC standard for use
of moisture/reflow sensitive surface-mount devices.



Sensor display comes with built-in
alarm function.



Calibration reminding function.

Performance

Outstanding Humidity Control

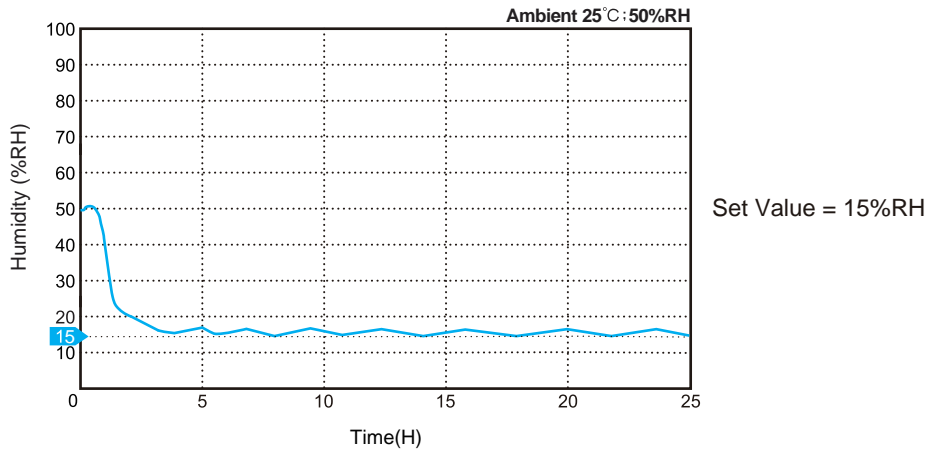

Specifications

Model	A15U-1200-6	A15U-600	A15U-400	A15U-200	A15U-575	A15U-315	A15U-157
External Size W*D*H(mm)	1200*672*1820	600*672*1820	600*672*1274	600*672*636	905*800*1045	905*452*954	450*452*954
Internal Size W*D*H(mm)	1155*580*1588	555*580*1588	555*580*1042	555*580*496	860*720*840	860*380*840	405*380*840
Capacity(L)	1250	624	413	202	598	328	164
Adjustable Shelves	4pcs of 1-2 1pc of 1-1	4pcs of 1-4 1pc of 1-3	2pcs of 1-4 1pc of 1-3	1pc of 1-4 1pc of 1-3	2pcs of 1-6 1pc of 1-5	2pcs of 1-8 1pc of 1-7	2pc of 1-10 1pcs of 1-9
Door(s)	6	3	2	1	2	2	1
Sensor Display	Precision : ±3%RH (@25°C , 15~50%RH) , ±1°C / Resolution : 0.1%RH , 0.1°C / Embedded RS-232 port and built-in alarm function						
Cabinet Structure	1mm carbon steel / Glass window(s) and gray window frame. Grounding wire: 1MΩ(length 930mm)						
Voltage	110V or 230V (Select In Advance)						
Power Consumption	110V : 18Wh(Ave.) , 155W(Max.) / 230V : 18Wh(Ave.) , 170W(Max.)						

The best performance is achieved under the ambient condition below 25°C and 50%RH

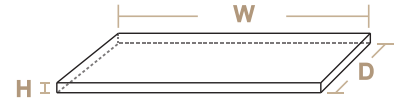

Item	①	Item	Model	Size
Item Name	Shelf	① - 1	1200-6	W1155*D530*H20mm
Picture		① - 2	1200-6	W1155*D580*H20mm
		① - 3	600/400/200	W555*D530*H20mm
		① - 4	600/400/200	W555*D580*H20mm
		① - 5	575	W860*D645*H20mm
		① - 6	575	W860*D720*H20mm
		① - 7	315	W860*D310*H20mm
		① - 8	315	W860*D380*H20mm
		① - 9	157	W405*D310*H20mm
		① - 10	157	W405*D380*H20mm

Item	②	③	④	⑤
Item Name	GT-05 Data Logger	External Alarm Tower	QDN	Flow Meter
Description	Memory capacity 40,000 records.	When the Rh exceeds the preset value, it will flash and buzz (100-120 dB).	The nitrogen will stop as soon as the relative humidity reaches preset value. Inlet dia. : ∅ 8mm	Spec:10-60L/min Inlet dia. : ∅ 8mm
Picture				

Item	⑥	
Item Name	Storage Bin	
Description	Max Load Weight : 5kg External Size : W395*D40*H98mm Internal Size : W365*D30*H90mm	Max Load Weight : 5kg External Size : W237*D40*H98mm Internal Size : W210*D28*H87mm
Picture	<p>Available for A15U-1200-6/600/400/200</p>	<p>Available for A15U-575/315/157</p>