

Surtronic[®] R-150



High speed roundness measurement systems for the bearings, automotive and precision industries

Surtronic® R-150

High speed roundness measurement system **Bearings, automotive & precision industries**





A roundness product, robust enough for the shop floor but accurate enough for any inspection room.

Working closely with bearings manufacturers, Taylor Hobson has focussed on the key attributes that are most important for quality control in today's precision industries.

The Surtronic® R-150 offers a flexible solution for roundness and form requirements with a variety of application specific software options and accessories, along with fixtures that can be tailored to your specific need.



World's highest throughput roundness system...

-  Incoming inspections
-  Final inspection before shipment
-  Process control on the production line
-  Checking large components and structures

What can it measure...

The Surtronic® R-150 is ideally suited to measuring high volume production parts across a wide variety of industries including:

- **Bearings** – Races, Balls, Needles and Rollers
- **Automotive** – Valves, Con Rods, Pins and Brake discs
- **Process Control** – Grinding, Turning, Milling and Honing

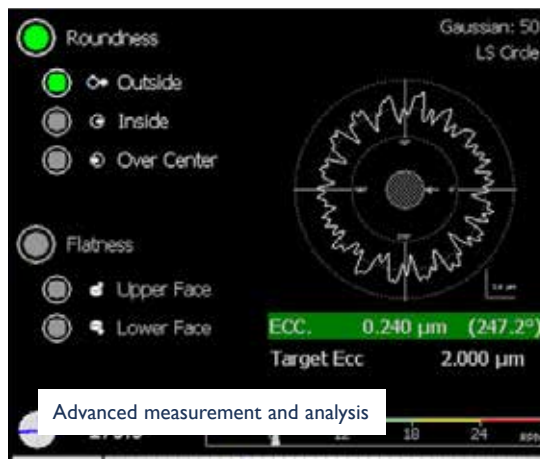

Key features

Speed - 3 parts/min. including set-up

The most important benefit these systems offer is speed. In precision industries as manufacturing volumes increase all too often the bottleneck is metrology.

High measurement throughput systems ensure higher sampling rates are achieved while also supporting increased manufacturing volumes.

Ease of use - Touchscreen software

The X-sight touch screen software platform with intuitive navigation make the Surtronic® Roundness as easy to use as a SatNav or SmartPhone with everything you need at your fingertips.

Robustness - Suitable for 24/7 operation

All systems are designed for constant 24 hour, 7 days a week use in demanding shop floor environments; manufactured using only the most durable and hard wearing materials.

Precision - ± 25 nm spindle accuracy

Although many times faster than traditional benchtop roundness systems there is no loss of precision or accuracy.

Full ISO compliant measurements can be taken with ± 25 nm accuracy and 6 nm gauge resolution.

Surtronic® R-150

More than a measurement instrument... A new measurement concept

Surtronic® R-150 powered by New Windows® 10 tablet

The Surtronic® R-150 with Windows® 10 tablet allows for wireless data transfer to networks.

All measurement data can be saved with filetypes including PDF and PNG by using the easy to use software interface.

The Windows® 10 tablet with Gorilla Glass 3.0, is highly resistant to scratches and sharp contact damage. It provides up to a 4x improvement in scratch resistance when compared to other aluminosilicate glasses

Easy to use software

The icon-based user interface provides simple measurement and analysis.

- Developed in collaboration with key bearings, automotive and precision engineering companies
- Large colour display, easy viewing of results
- Touch screen operation means every feature at your fingertips
- Easy analysis setup with single button recall
- Advanced analysis packages for bearings and automotive applications

Patented RapidCentre™

RapidCentre™ avoids valuable cycle time being lost on manual part centring. On most parts precision results are achieved following a very simple and fast loading procedure. Now roundness measurements can be made in less than 30 seconds including part loading, centring, measurement, analysis and results display!

Accurate gauging

All systems incorporate Taylor Hobson's accurate and reliable Talymin gauge technology, delivering 6 nm resolution.

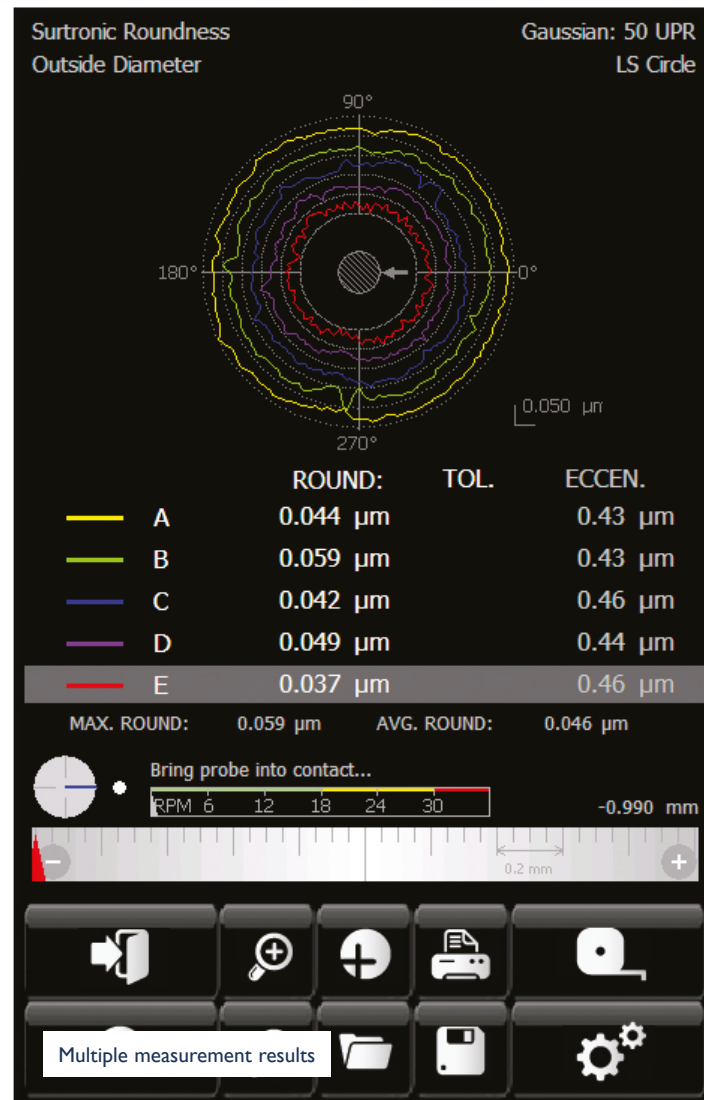

Accessories and standards

A full range of accessories and standards are available to support the instrument. These include Magnetic chuck, RapidCentre™, Glass hemisphere, Calibration set, Precision test cylinder, Cresting standard, Stylus kit, Flick standard (20 μm or 300 μm) and replacement air filter modules.

Patented gauge orientation

Using Taylor Hobson's patented gauge orientation with its robust locking mechanism changing orientation from roundness to flatness or internal to external only takes a few seconds.

“ We have 15 Taylor Hobson roundness measuring instruments that help us maintain high throughput and the accuracies we require to ensure every one of our bearings is of the highest quality ”

Measurement Q/A Coordinator | Leading Global Bearings Manufacturer

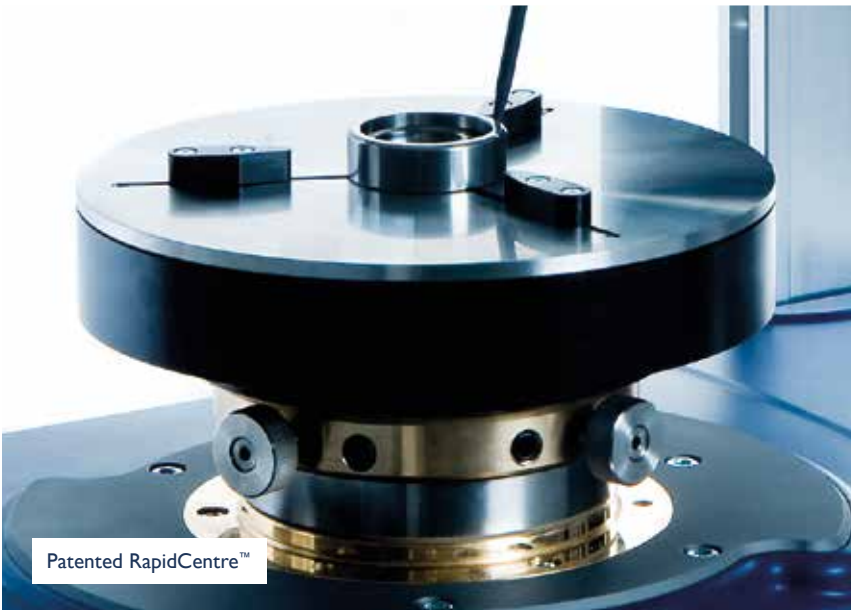

Patented RapidCentre™

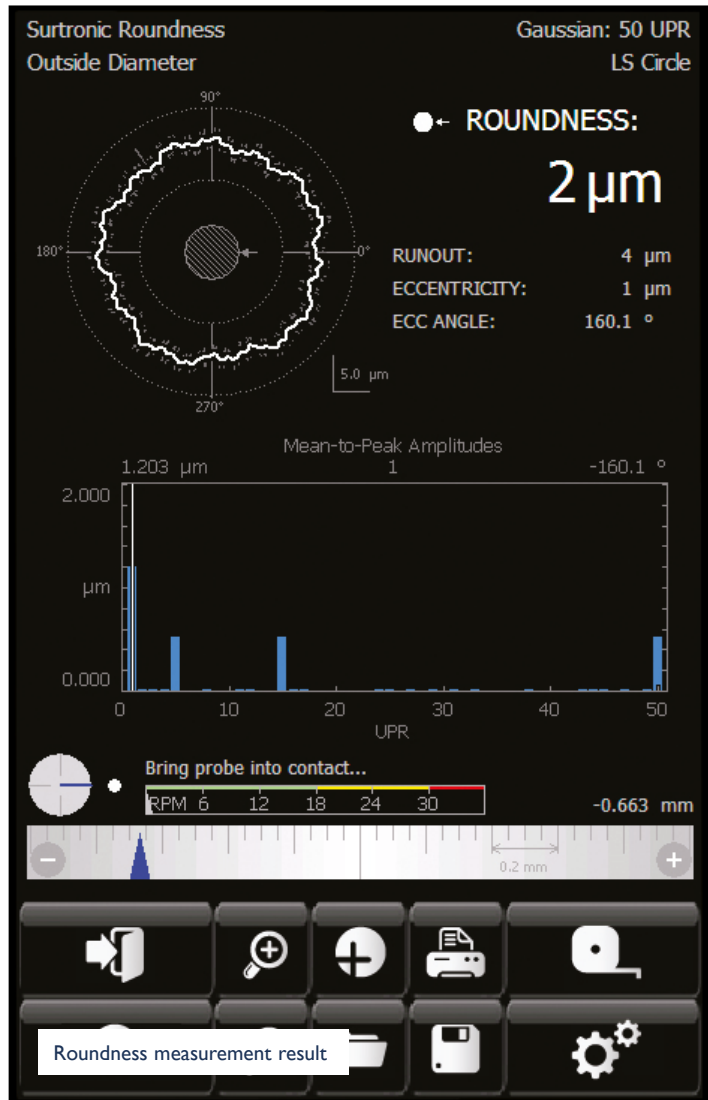

Miniature bearing



Glass hemisphere

Precision measurement

Ultra precision bearings are produced to the highest standards available.

They are used in industries with a necessity for critical tolerances, high speeds and reliable performance under demanding operating conditions. Ultra precision bearings are also used in safety-critical and harsh environment applications and industries such as:

- Automotive
- Aerospace
- Bearings
- Hydraulics
- Optics
- Industrial
- Medical
- Dental



Applications

Bearing components



Ball bearings



Balls



Needle and roller bearings

Monitoring manufacturing



Grinding



Turning



Milling



Honing

Join the roundness revolution

Whatever your industry or application if you need high speed roundness measurement we have it covered....



Roundness



Eccentricity



Squareness



Harmonic analysis



Flatness



Concentricity



Parallelism



Thickness variation



Coaxiality



Radial runout

Analysis

Analysis	Measurement mode	Evaluation diagram	Surtronic® R-150	Analysis	Measurement mode	Evaluation diagram	Surtronic® R-150
Roundness			✓	Squareness			✓
Flatness			✓	Parallelism			✓
Coaxiality			✓	Measure Interrupted Surface			✓
Concentricity			✓	Harmonic Analysis			●
Eccentricity			✓	Thickness Variation			●
Runout	Axial		✓	Axial			●
	Radial		✓				

✓ = Included ● = Optional
 (Customer specific analysis available on request)

Specification

Measuring capacity	
Max. diameter	300 mm (11.8 in)
Max. height	280 mm (11.0 in)
Max. weight	20 kg (44 lbs)

Spindle	
Speed of rotation	15 Rpm Max.
Radial limit of error (departure from the LS circle)	± 25 nm @ 6 Rpm

Gauge	
Range	2 mm (0.08 in)
Resolution	6 nm (0.24 µin)

Work table	
Diameter (standard)	125 mm (4.9 in)
Diameter (accessory)	300 mm (11.8 in)
Centering	± 1.25 mm (± 0.05 in)
Levelling	30 arc minutes
Height of neutral plane	51 mm (2.0 in)

Filter	
Type	None, Gaussian, Robust Gaussian, 2 CR-PC, Fourier
Standard filter cut-offs	1–15 µm; 1–50 µm; 1–150 µm; 15–150 µm; 1–500 µm; 15–500 µm
Special filters	User selectable & Bandpass

Environmental conditions	
Operating temperature	10°C - 35°C (50°F - 95°F)
Temperature / time gradient	< 2 °C per hour (< 3.6 °F per hour)
Operating humidity	30% to 80% relative, non-condensing
Storage	10% to 90% relative, non-condensing
Free air flow rate	1.0 m / sec maximum steady (39.4 in / sec)

System features		
Roundness / flatness		✓
Coaxiality / eccentricity		✓
Concentricity / radial runout		✓
Squareness		✓
Parallelism		✓
Measure interrupted surfaces		✓
Harmonic analysis		●
Thickness variation		●
Advanced harmonics		●

Weight (without fixtures)	
Surtronic® R-150	40 kg

Electrical (alternating supply, single phase with earth, 3-wire)	
Voltage	90 to 260 V
Frequency	47 to 63 Hz
Consumption (total system)	250 VA max, 160 W

Air source requirements	
Max. source pressure	8.1 bar (120 psi)
Min. source pressure	5.4 bar (80 psi)
Air consumption	0.037 cu.m / min (1.3 cfm)
Operating pressure	4.1 bar (60 psi)
Filtering	5 µm (200 µin)
Moisture content – dewpoint	2 °C (35.6 °F)

CE Low Voltage Directive 2014/35/EU, EMC Directive 2014/30/EU, Machinery Directive 2006/42/EC, RoHS Directive 2011/65/EU

Compliance to directives is demonstrated using applicable European standards and sections therein.

✓ = Included ● = Optional
(Customer specific analysis available on request)

All accuracies and uncertainties are quoted at 20°C ± 1°C (68°F ± 1.8°F) with 1-50 µm Gaussian filter at 6 rpm.

Taylor Hobson pursues a policy of continual improvements due to technical developments. We therefore reserve the right to deviate from catalogue specifications.

Floor plan

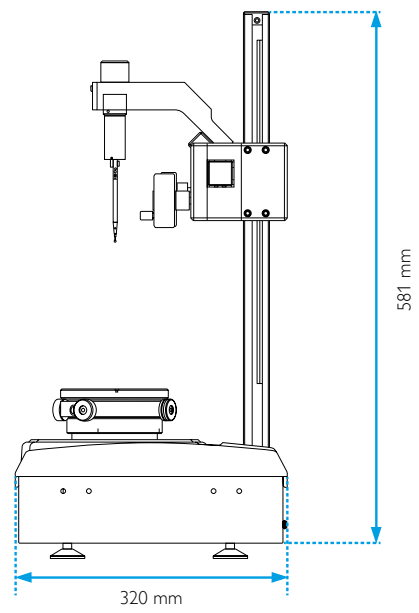
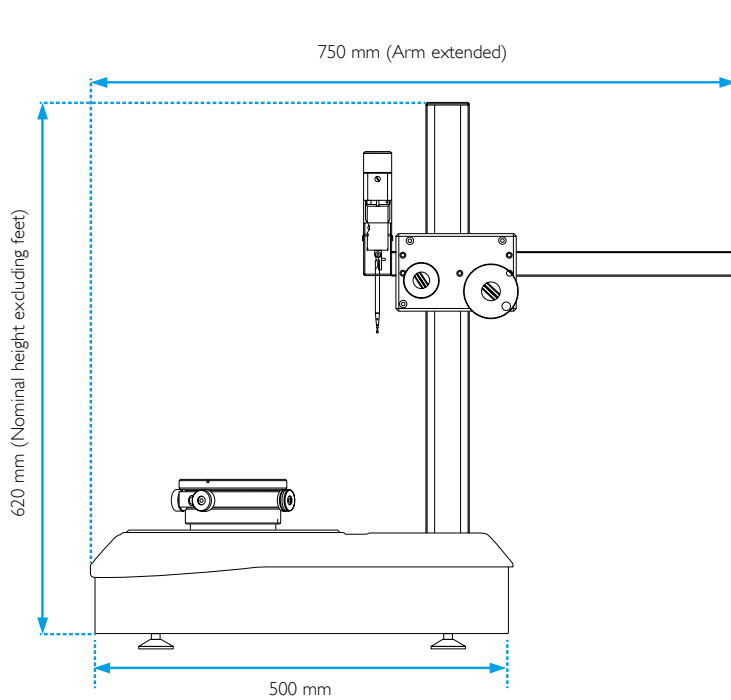

3 M5 x 8 mm deep tapped holes
 Equi-spaced on the following PCDs
 Ø 25.3 mm (± 0.05 mm)
 Ø 58.7 mm (± 0.15 mm)
 Ø 92.5 mm (± 0.4 mm)

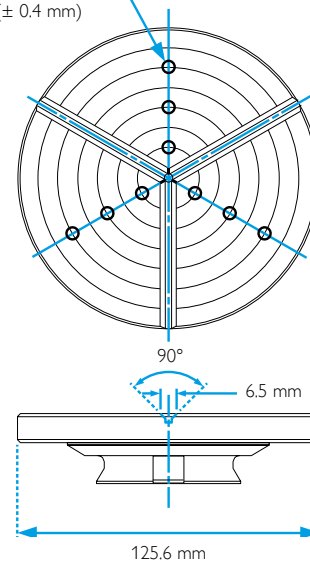
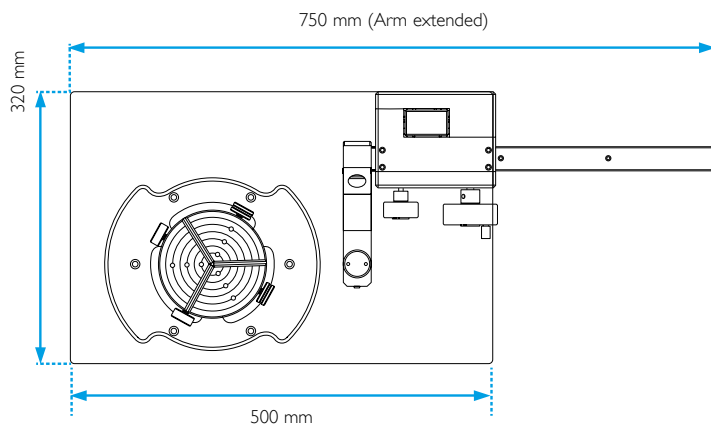

Accessories

All the accessories you need to begin using Taylor Hobson roundness measuring systems are supplied as standard. However, for more demanding requirements or improved measurement throughput, we have a range of accessories which may be ordered separately.

1 Flick standard

For rapid calibration of the gauge head; alternative to the standard gauge calibration set.

20 μm (788 μin) range
code 112-2308*

300 μm (0.012") range
code 112-2233*

2 Stylus arms

Ruby ball \times 100 mm (3.94").

1 mm (0.039in) diameter;
code 112-3245

2 mm (0.078in) diameter;
code 112-3244

4 mm (0.157in) diameter;
code 112-3243

Bar Stylus

A 100 mm (3.9 in) stylus for measuring small diameter components.

code 112-3489

3 Six jaw component chuck

A 6 jaw precision scroll chuck.

Capacity - Inside diameter
20 mm - 95 mm (0.78 in - 3.74 in).

Capacity - Outside diameter
2 mm - 32 mm (0.08 in - 1.26 in).

code 112-1859

4 Glass hemisphere

For checking total system performance; UKAS calibration certificate is optional.

Roundness $<$ 0.02 μm (0.8 μin)

code 112-2324*

5 Calibration set

For calibrating the gauge head.
Comprises a circular glass flat and three gauge blocks (2.5 mm, 2.8 mm and 3 mm).

code 112-2889*

6 Cresting pin

For checking the vertical and horizontal alignment of the gauge head.

code 112-4313

7 Precision collet chuck – removable

Three ball type location.

code 112-4313

Note: Collet required – see below.

- 112/3554-1.0 - 1 mm collet
- 112/3554-1.5 - 1.5 mm collet
- 112/3554-2.0 - 2 mm collet
- 112/3554-2.5 - 2.5 mm collet
- 112/3554-3.0 - 3 mm collet
- 112/3554-3.5 - 3.5 mm collet
- 112/3554-4.0 - 4 mm collet
- 112/3554-4.5 - 4.5 mm collet
- 112/3554-5.0 - 5 mm collet
- 112/3554-5.5 - 5.5 mm collet
- 112/3554-6.0 - 6 mm collet
- 112/3554-6.5 - 6.5 mm collet
- 112/3554-7.0 - 7 mm collet
- 112/3554-7.5 - 7.5 mm collet
- 112/3554-8.0 - 8 mm collet

8 RapidCentre™

For repeatable centering of small components. Standard range available, please contact Taylor Hobson for a customised solution.

Kinematic dowel support set

For stable workpiece mounting.

code 112-1861



Customised solutions for special applications

Our strategy for success is simple, instead of just selling products, we provide solutions. If our standard instruments and accessories do not satisfy your needs, we can customise a solution to match your application.

Specifications are subject to change without notice.

Surtronic® product range

Surtronic® Duo II - Measure surface roughness at the touch of a button and shows the result on a large colour LCD screen. Cycle time is 5 seconds and the result is saved until another measurement is taken.

- Ready to use out of the box
- Battery life more than 10,000 measurements

Z Range	200 µm (7800 µin)
Resolution	0.01 µm (0.4 µin)
Accuracy	5% of reading + noise



Surtronic® S-100 Series - the very latest technology in high speed shop floor surface roughness measurement. The S-100 features a modern touchscreen interface, high power Li-ion battery and impact resistant mouldings.

- Unique stylus lift for total flexibility
- 25 mm traverse length & 70 mm reach into bores
- Free Talyprofile analysis software available to download

Gauge range / resolution	400 µm (0.012 in) / 0.01 µm (0.4 µin)
Accuracy (5 µm diamond tip)	2% of reading + noise



Intra Range - Measure roughness, waviness and contour. A low cost, portable system for high level surface texture analysis on the shop floor.

- 50 mm (1.97 in) traverse with straightness datum
- Up to 32 mm range with the wide range gauge
- Fast and easy calibration over a sphere

Gauge range / resolution	WR ¹ - 32 mm range (1.26 in) / 15 nm (0.59 µin) HP ² - 2 mm (0.08 in) / 0.8 nm (0.03 µin)
Straightness accuracy	0.15 µm over any 20 mm (5.91 µin over any 0.79 in)

1. Wide Range gauge option. 2. High Precision gauge option.



Talyrond® 170 Raceway - A high speed roundness measurement system designed specifically to address the extreme demands of high volume bearing production measurement.

- Robustness - suitable for 24/7 operation
- Integrated Spindle Protection System
- High resolution crest drive
- Ergonomic system layout

Gauge resolution	6 nm (0.24 µin)
Spindle accuracy	±15 nm (0.59 µin)



The Metrology Experts

Established in 1886, Taylor Hobson is the world leader in surface and form metrology and developed the first roundness and surface finish measuring instruments.

www.taylor-hobson.com

Sales department

Email: taylor-hobson.sales@ametek.com

Tel: +44 (0) 116 276 3771

- **Design engineering** – special purpose, dedicated metrology systems for demanding applications.
- **Precision manufacturing** – contract machining services for high precision applications and industries.

Centre of Excellence department

Email: taylor-hobson.cofe@ametek.com

Tel: +44 (0) 116 276 3779

- **Inspection services** – measurement of your production parts by skilled technicians using industry leading instruments in accord with ISO standards.
- **Metrology training** – practical, hands-on training courses for roundness and surface finish conducted by experienced metrologists.
- **Operator training** – on-site instruction will lead to greater proficiency and higher productivity.
- **UKAS calibration and testing** – certification for artifacts or instruments in our laboratory or at customer's site.

Service department

Email: taylor-hobson.service@ametek.com

Tel: +44 (0) 116 246 2900

- **Preventative maintenance** – protect your metrology investment with an AMECare support agreement.



© Taylor Hobson Ltd. 2020



Taylor Hobson UK

(Global Headquarters)

PO Box 36, 2 New Star Road
Leicester,
LE4 9JQ,
England

Tel: +44 (0)116 276 3771
taylor-hobson.sales@ametek.com



Taylor Hobson France

Rond Point de l'Épine Champs
Batiment D, 78990 Elancourt, France
Tel: +33 130 68 89 30
taylor-hobson.france@ametek.com



Taylor Hobson Germany

Rudolf-Diesel-Straße 16,
D-64331 Weiterstadt, Germany
Tel: +49 6150 543 0
taylor-hobson.germany@ametek.com



Taylor Hobson Italy

Via Della Liberazione 24, 20068, Peschiera
Borromeo, Zelofoaramagno, Milan, Italy
Tel: +39 02 946 93401
taylor-hobson.italy@ametek.com



Taylor Hobson India

Divyasree NR Enclave, 4th Floor, Block A,
Plot No. 1, EPIP Industrial Area, Whitefield,
Bengaluru - 560066, India
Tel: +91 80 6782 3346
taylor-hobson.india@ametek.com



Taylor Hobson China

taylor-hobson-china.sales@ametek.com

Shanghai Office

Part A1, A4, 2nd Floor, Building No. 1, No. 526
Fute 3rd Road East, Pilot Free Trade Zone,
Shanghai, 200131, China
Tel: +86 21 5868 5111-110

Beijing Office

Western Section, 2nd Floor, Jing Dong Fang
Building (B10), No. 10, Jiu Xian Qiao Road,
Chaoyang District, Beijing, 100015, China
Tel: +86 10 8526 2111

Chengdu Office

No. 9-10, 10th floor, 9/F, High-tech Incubation
Park, No. 160, Jinyue West Road, Chengdu
610041, China
Tel: +86 28 8675 8111

Guangzhou Office

Room 810 Dongbao Plaza, No.767 East
Dongfeng Road, Guangzhou, 510600, China
Tel: +86 20 8363 4768



Taylor Hobson Japan

3F Shiba NBF Tower; 1-1-30, Shiba Daimon
Minato-ku, Tokyo 105-0012, Japan
Tel: +81 34400 2400
taylor-hobson.japan@ametek.com



Taylor Hobson Korea

#309, 3rd FL, Gyeonggi R&DB Center; 105,
Gwanggyo-ro, Yeongtong-gu, Suwon-si,
Gyeonggi-do, Korea, 16229
Tel: +82 31 888 5255
taylor-hobson.korea@ametek.com



Taylor Hobson Singapore

20 Changi Business Park Central 2,
#04-03/04, Singapore 486031
Tel: +65 6484 2388
taylor-hobson.singapore@ametek.com



Taylor Hobson Thailand

89/45, Moo 15, Enterprise Park, Bangna-Trad
Road, Tambol Bangkaew, Amphur Bangplee,
Samutprakarn Province 10540, Thailand
Tel: +66 2 0127500 Ext 505
taylor-hobson.thailand@ametek.com



Taylor Hobson Taiwan

10F-5, No.120, Sec. 2, Gongdao Wu Rd.,
Hsinchu City 30072, Taiwan
Tel: +886 3 575 0099 Ext 301
taylor-hobson.taiwan@ametek.com



Taylor Hobson Mexico

Acceso III No. 16 Nave 3 Parque Ind. Benito
Juarez Queretaro, Qro. Mexico C.P. 76120
Tel: +52 442 426 4480
taylor-hobson.mexico@ametek.com



Taylor Hobson USA

27755 Diehl Road, Suite 300, Warrenville,
IL 60555, USA
Tel: +1 630 621 3099
taylor-hobson.usa@ametek.com



1100 Cassatt Road, Berwyn, PA 19312, USA
Email: info.corp@ametek.com
Web: www.ametek.com