

AP&T[®]

AP-AB1123



Static Removal Ion Bar

Electroshock proof / High efficiency

Shanghai Anping Static Technology Co.,Ltd

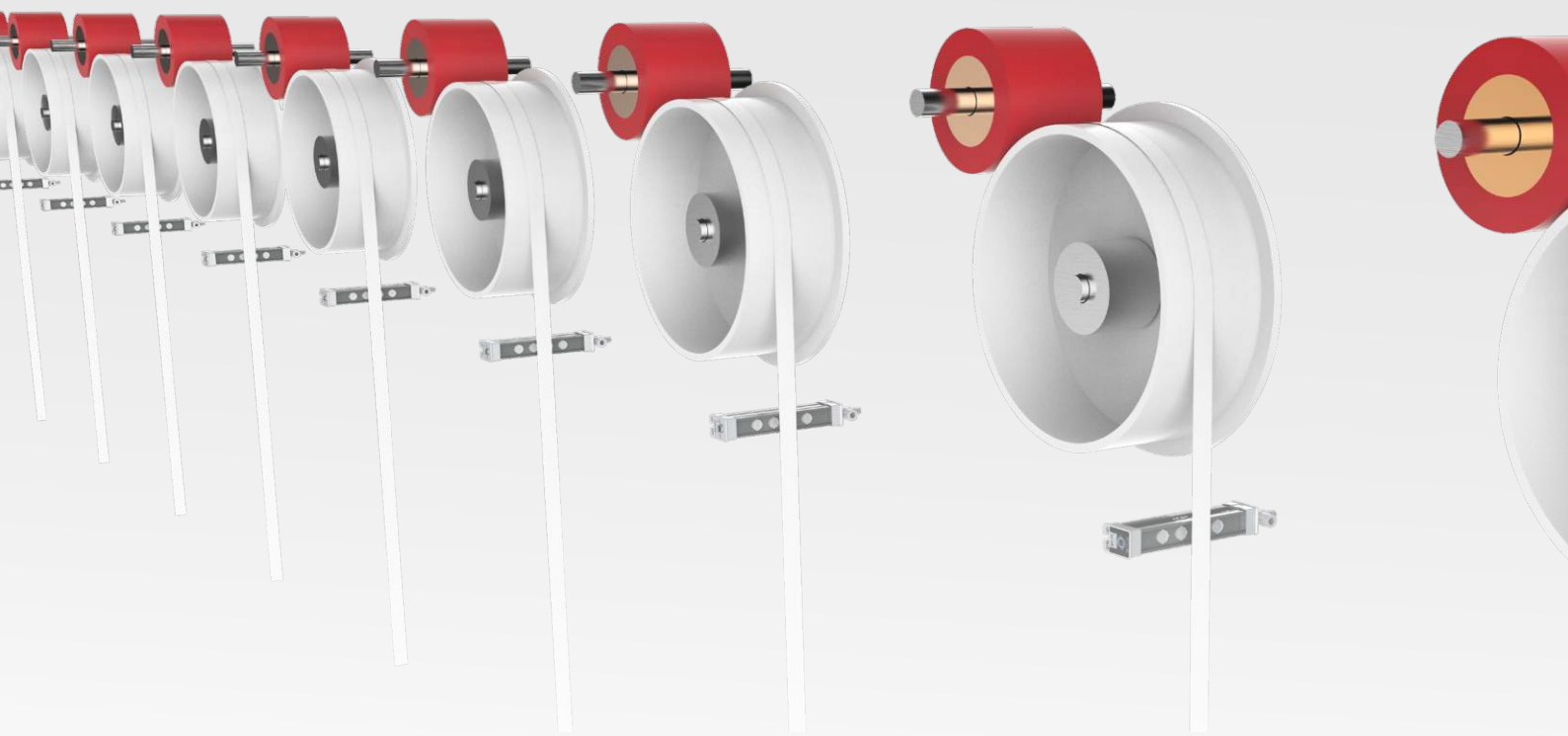

Suitable for film, plastic, textile, printing and other industries

Effectively solve the problems caused by
static electricity



Static Removal

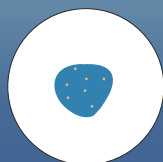

Prevent adhesion of objects



Prevent blockage of adhesion

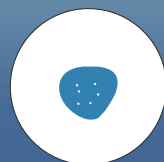

Control ink splashing



Prevent uneven scattering

High efficiency static removal

Keep a clean production environment and stay away from static electricity

Discharge effect

Without air source Bar Length 1500mm

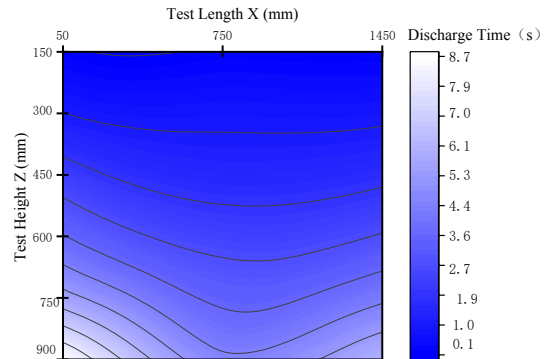
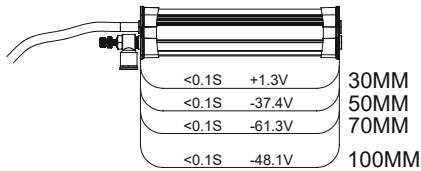

Discharge time distribution diagram of AP-AB1123 with 1500mm bar length at 0.3MPa air pressure

With air source Air Pressure 0.3Mpa, Bar Length 1500mm

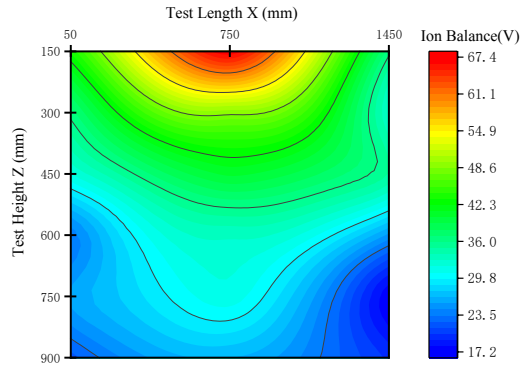
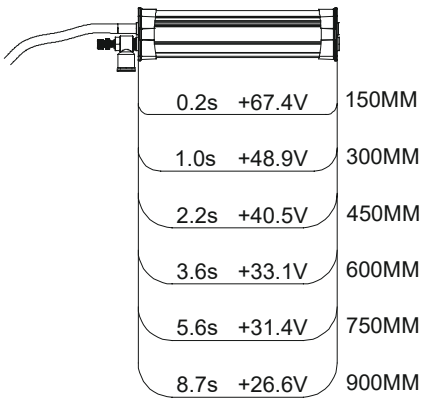

Ion balance voltage distribution diagram of AP-AB1123 with 1500mm bar length at 0.3MPa air pressure

Test standard:

Note: The first and last pin at left and right end are aligned with the edge of the plate

Test standard: ANSI/ESD.STM3.1, SJ/T 11446-2013

Test instrument: Trek158A flat charge tester

Test voltage: $\pm 1000V \rightarrow \pm 100V$ attenuation

Test environment: humidity $50 \pm 5\%$; temperature $23 \pm 3^\circ C$

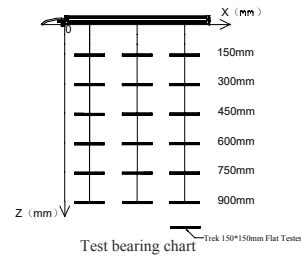

Working way

AP-AB1123 ion bar adopts power frequency AC high voltage acting on special emission electrode to ionize air molecules through impedance coupler, producing positive and negative ions and transport to object surface to be static eliminated, neutralize positive and negative static charge and achieve efficient and reliable elimination of static electricity.

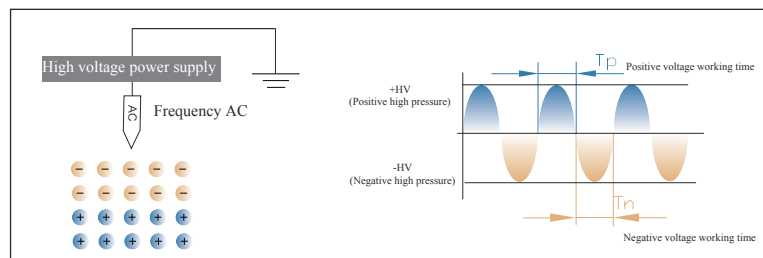

Features

Safe / Easy to use / Durable



No.1

Electroshock-proof

Protection against human shock.

No.2

Standard tungsten alloy needle

Tungsten alloy has a longer service life compared with titanium and silicon materials.



No.3

CE certification

It can effectively prevent the external electromagnetic interference from affecting the normal operation of the ion bar. This is a static electricity eliminator with high safety and high reliability.

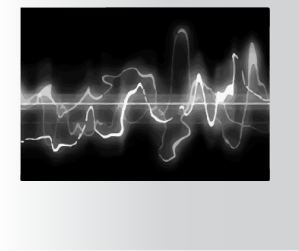

No.4

Easy to replace the discharge part

Rotating the needle holder counterclockwise to replace the needles when it is damaged off.

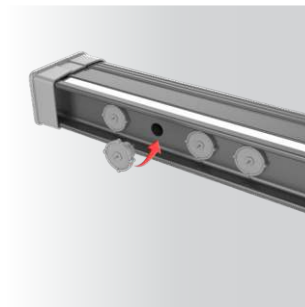

»»»» Product Specification ««««

Model	AP-AB1123
Working voltage	one bar length < 1m or two bars length < 1m: AC5600V one bar length ≥ 1m or two bars length ≥ 1m: AC7000V
Power	20W
Ion emission	Power frequency AC
Emitter electrode	Tungsten
Discharge structure	Resistance coupling
Discharge range	without air source: (175mm→3000mm) *300mm*100mm with air source: (175mm→3000mm) *300mm*600mm
Installation distance	without air source : 30→100mm with air source: 100→600mm
Ion balance	≤ ±50V (AVG)
Discharge speed	without air source : ≤1.0S (Test distance 100mm) with air source: ≤2.0S (Test distance 300mm)
Compressed air connector	Φ8-G1/8 Black
Compressed air requirement	Clean dry air
Working temperature	0°C - 45°C
Working humidity	< 70%
Dimensions	(175mm→3000mm) *31.2mm*46.5mm
Bar material	Flame retardant PVC, SUS
Packaging accessories	M5-12*12*4 square mounting nuts
Power supply	AP-AY1506 : one bar length < 1m; AP-AY2506 : two bars length < 1m AP-AY1504 : one bar length ≥ 1m; AP-AY2504 : two bars length ≥ 1m
Power cord	2.5m (Can be customized according to requirements, Max size is 10m)
Warranty	1 Year
Certification	CE / RoHS

»»»» Product Dimension ««««

Unit: mm

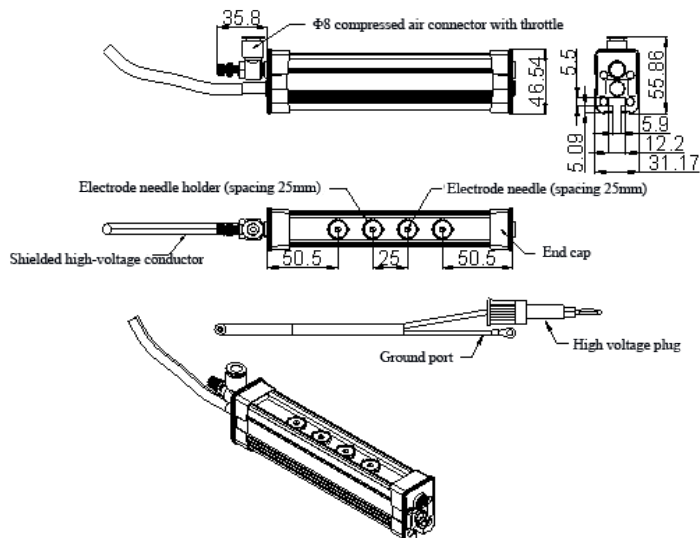

Product Usage

Step of use/Installation position/Packing accessories

Step of use

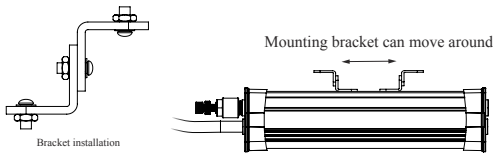

1

Take out ion bar, power cable, stainless steel mounting bracket and other accessories from the packing box, and install the stainless steel mounting bracket on the mounting slot of the ion bar base.

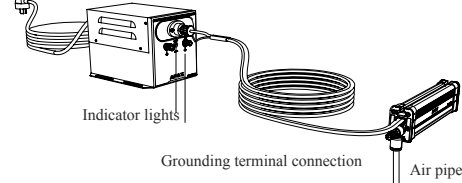

2

Insert the high-voltage plug of the bar into the high-voltage output connecting seat of the matching high-voltage power supply. Connect the grounding terminal of the bar body to the grounding stud of the high voltage power supply. Turn on the power supply and indicator light on shows the power work. The electrode pins will produce positive and negative ions to neutralize the surface static electricity of the object. Connect the air source connector on the bar body to the air generating equipment when air connection is required and turn on the air source switch.

Installation position

1. Select the best static discharge position after electrostatic detection of the working environment on site and install the bar body and the supporting power adapter firmly. (Installation distance is shown below)



2. Ion bar strip grounding electrode is not allowed to be covered by other objects.

3. Two ion bars should be install side by side with an interval of 100mm (without air)/300mm (with air) or more .

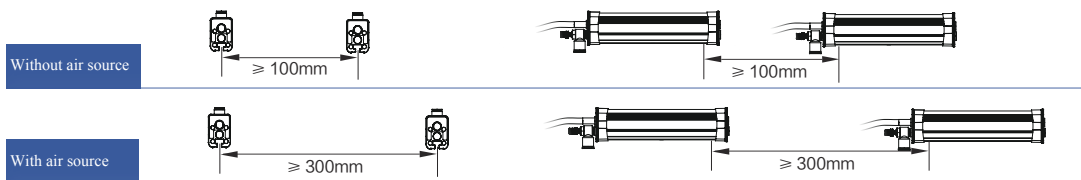

4. More than 200mm away from obstacles such as walls.

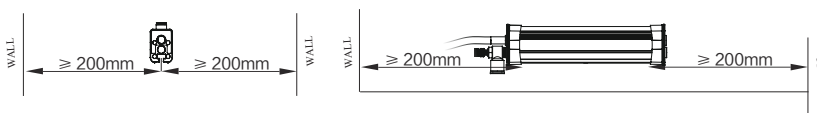

5. Ion bar should be at least 30mm away from the metal conductor and metal grounding body around the electrode and the bar body must be reliably connected to the ground wire.

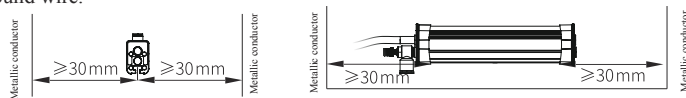

Packing accessories

Part name	Picture	Part No.	Specification	Quantity
L-shaped stainless steel mounting bracket		AP8038005	Height 25mm / Wide16mm/ Thick 3mm Aperture5mm (Actual measurement4.8mm)	4
Square nut		AP8933000	M5*12*12*4	2
304 Stainless steel spring washer		AP8943000	M5	6
304 Stainless steel flat gasket		AP8946004	M5	6
304 Stainless steel pan head cross screw		AP8900001	M5*12	6
Hexagonal nut		1LML05000	M5	4

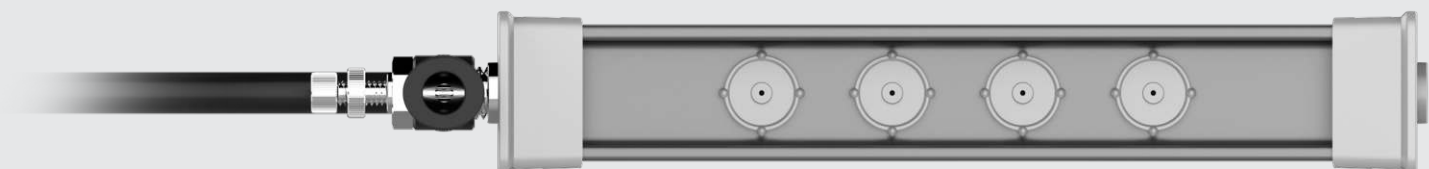

⚠ Safety warning

1. Read the operating instruction carefully before installing and using the device.
2. The whole equipment must be reliably grounded with a grounding resistance of less than 4 ohms during use; Otherwise, it is easy to cause abnormal or even damage of ion bar.
3. Do not use the device when the humidity is higher than 70%.
4. Do not use the device in inflammable and explosive environment.
5. It is strictly forbidden to disassemble products without authorization. Internal maintenance and repair must be carried out by professional personnel.
6. The product is strictly prohibited to touch liquid during use, otherwise there will be abnormal, resulting in electric shock or fire.
7. Power must be turned off during inspecting or replacing the product, otherwise it may cause electric shock or fire.
8. The product is specially designed for removing static electricity and is strictly prohibited for other purposes. Any abnormal use may cause machine failure, electric shock, fire and other hidden dangers.
9. It is strictly forbidden to touch the electrode needles when power is on, otherwise it is easy to cause fault and electric shock accident.
10. Discharge needle is a sharp metal object, please use it with care.
11. Please check the specifications of the power supply before powering on the product. Any power supply that does not meet the specifications may cause damage or even failure to the product.
12. Check the power cord regularly. If it is damaged, replace it immediately; otherwise, leakage and abnormal operation may occur.

⚠ Trouble shooting

NO	Problems	Reasons	Solutions
1	The electrostatic removal performance is obviously reduced	Discharge needle is polluted and damaged	Clean or replace the ion bar
		Set bearing of ion bar is improper	Confirm the best set bearing
2	The electrostatic removal performance is reduced	There are conductors or other ion bars around the ion bars	Remove conductors or other ion bars
3	Unable to discharge	High-voltage connecting wire is damaged	Return to factory for maintenance
		Ion bar insulation is damaged	Return to factory for maintenance
		Poor grounding/no grounding	Check the electrical grounding of ion bar and plant equipment
4	Product burnout	Ion bar insulation is damaged	Return to factory for maintenance

⚠ Maintenance

1. In order to ensure the good performance of the product, it should be cleaned and maintained in time according to the use environment and the required electrostatic protection requirements, that is, using electrostatic brush, dust-free cotton swab, dust-free cloth dipped in anhydrous alcohol to gently remove the carbon deposit on the electrode and bar body, and its performance will be significantly improved. Note:
 - A. Operation must be done 10 minutes after power cut off.
 - B. When ash or white stuff appears on the needle during using the ion bar, it shall be cleaned. Use a dust-free cotton swab dipped in anhydrous alcohol to clean in case brush doesn't meet the cleaning requirements.
 - C. The ion bar must be powered on after alcohol is completely volatilized after cleaning. No other organic solvent can be used to clean the ion bar.
2. If the ion bar is found to be burned, it should be stopped and repaired by professional maintenance personnel. It can be used only after the electrical performance index is normal.

⚠ After-sales service

AP-AB1123 shock-proof high-efficiency AC ion bar has undergone rigorous testing and aging treatment before ex-work. Its performance has completely reached the relevant indicators marked in the use instructions.

1. AP&T promises to the customer that any defective parts inspected by AP&T will be repaired or replaced free of charge within one year from the date of purchase. However, this commitment does not apply to:
 - The equipment is used or installed incorrectly;
 - Damage caused by negligence or accident during use;
 - Modified, disassembled or repaired by other service departments not authorized by Anping Company.
2. The alloy electrode is a consumable product which is not included in the scope of warranty and will be charged for replacement when repairing.
3. AP&T shall not be liable for any incorrect use of the products except for repair or replacement of parts as specified above.

AP&T®

AP&T

Professional electrostatic intelligent monitoring/analysis
and elimination solution provider

Speciality Creates Value

Shanghai Anping Static Technology Co.,Ltd

Tel : +86-21-64517676

Fax : +86-21-64517673

Postcode : 200233

Website : www.ap-static.com

Address : 3/F,Building 27,No.69,Guiqing Road,Shanghai,China

