

# SCREWED END / SOCKET WELD END / BUTT WELD END 3-PIECE MOUNTING PAD FULL PORT BALL VALVE



## V3MH-316-PP TYPE

SIZE: 1/4"~4"

### STAINLESS STEEL

**AISI-316** (EN10213-4 1.4408) (ASTM-A351-CF8M)

**AISI-304** (EN10213-4 1.4301) (ASTM-A351-CF8)

### CARBON STEEL

**S-20C** (EN10213-2 1.0619) (ASTM-A216-WCB)

- FEATURES:**
- \* Pipe thread in accordance with ANSI B2.1, BS21 1973, DIN259/2999, ISO 228
  - \* Lug body
  - \* Blow-out proof stem/Full port
  - \* Investment casting body and cap
  - \* 1000PSI (69BAR) W.O.G.
  - \* Mounting Pad for ISO Standard 5211
  - \* Screwed end, butt weld end, socket weld end.

**OPTION:** Locking device

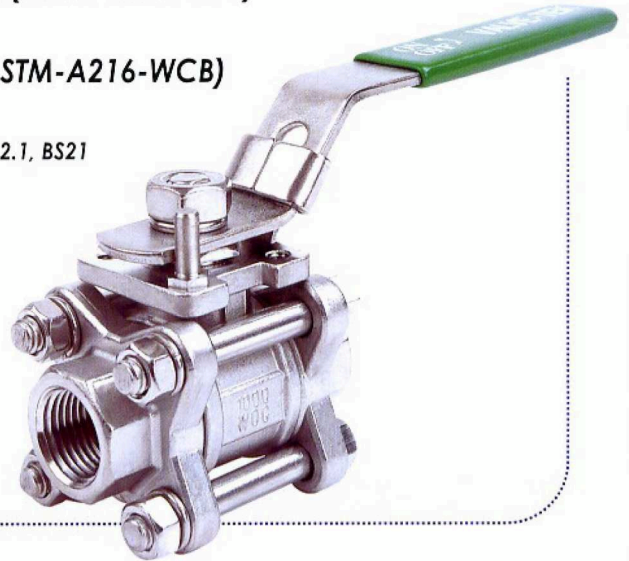

ITEM	PARTS	Q.TY	MATERIALS	
1	BODY	1	ASTM-A351-CF8M	ASTM-A216-WCB
2	CAP	2	ASTM-A351-CF8M	ASTM-A216-WCB
3	BALL	1	ASTM-A351-CF8M	ASTM-A351-CF8
4	BALL SEAT	2	PTFE	PTFE
5	JOINT GASKET	2	PTFE	PTFE
6	STEM	1	AISI 316	AISI 304
7	THRUST WASHER	1	PTFE	PTFE
8	STEM PACKING	2	PTFE	PTFE
9	GLAND NUT	1	AISI 304	AISI 304
10	HANDLE	1	AISI 304	AISI 304
11	SPRING WASHER	1	AISI 304	AISI 304
12	STEM NUT	1	AISI 304	AISI 304
13	PLASTIC COVER	1	PLASTIC	PLASTIC
14	LOCK DEVICE	1	AISI 304	AISI 304
15	BOLT	4(3"x4"x6 PCS)	AISI 304	
16	SPRING WASHER	4(3"x4"x6 PCS)	AISI 304	
17	HEX NUT	4(3"x4"x6 PCS)	AISI 304	
18	STOP PIN	1	AISI 304	AISI 304

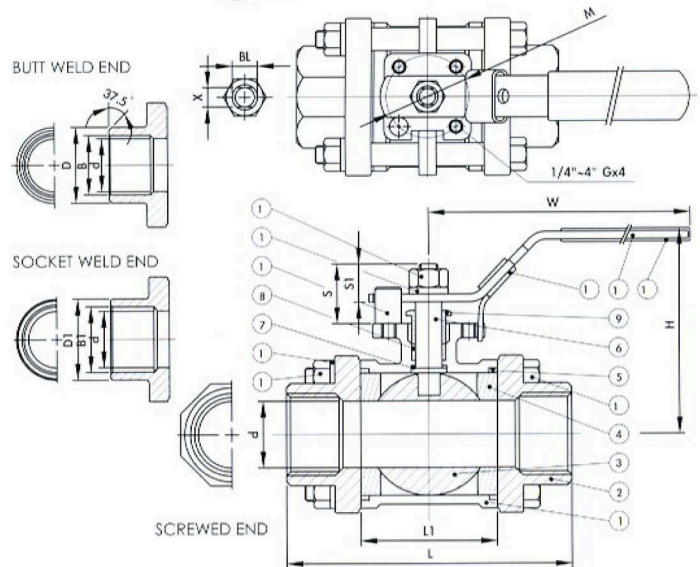

NOMINAL SIZE	DIMENSIONS														UNIT:mm			
	d	L	L1	H	W	S	S1	B	B1	D	D1	X	BL	ISO5211 M	G	Cv FACTOR	TORQUE kgf-cm	KGS
1/4"	11.6	58	21.2	55	105	13.3	8.3	12	14.1	17.6	19	5.0	5/16"	36	M5	6.6	40	0.34
3/8"	12.7	58	21.2	55	105	13.3	8.3	14	17.6	17.6	22.5	5.0	5/16"	36	M5	7.9	40	0.38
1/2"	15	62	23	60	105	15.8	9.8	17.1	21.7	21.5	27	5.0	5/16"	36	M5	11.2	54	0.5
3/4"	20	76	28	63	120	18.3	13.5	22.5	27.1	27	33	6.5	3/8"	36	M5	21	78	0.8
1"	25	85	35	79	158	21.5	15.6	28	33.8	34	40	8.0	7/16"	42	M5	35	106	1.17
1-1/4"	32	100	44.8	86	158	23	15.6	35.5	42.6	42.5	48.8	8.0	7/16"	42	M5	57	150	2.0
1-1/2"	38	115	55	94	195	25	16.9	43	48.7	49	55	9.0	1/2"	50	M6	80	200	2.5
2"	50	132	66.4	103	195	23.1	16.9	53	61.1	60.8	67.2	9.0	1/2"	50	M6	150	280	3.7
2-1/2"	65	165	84	133	245	41.2	30	65	76.9	76.2	86.4	12	3/4"	70	M8	265	500	7.4
3"	80	183	97.2	144	245	39.7	30	80	89.5	92	103	12	3/4"	102	M10	415	770	12.8
4"	100	232	125.4	177	320	47.1	36.6	100	115.4	116	130.7	16	1"	102	M10	780	1100	23



tel. +603 5191 4299  
fax. +603-5191 7299

email: sales@wogscontrol.com  
website: www.wogscontrol.com

A FELLBACH Group Products.